

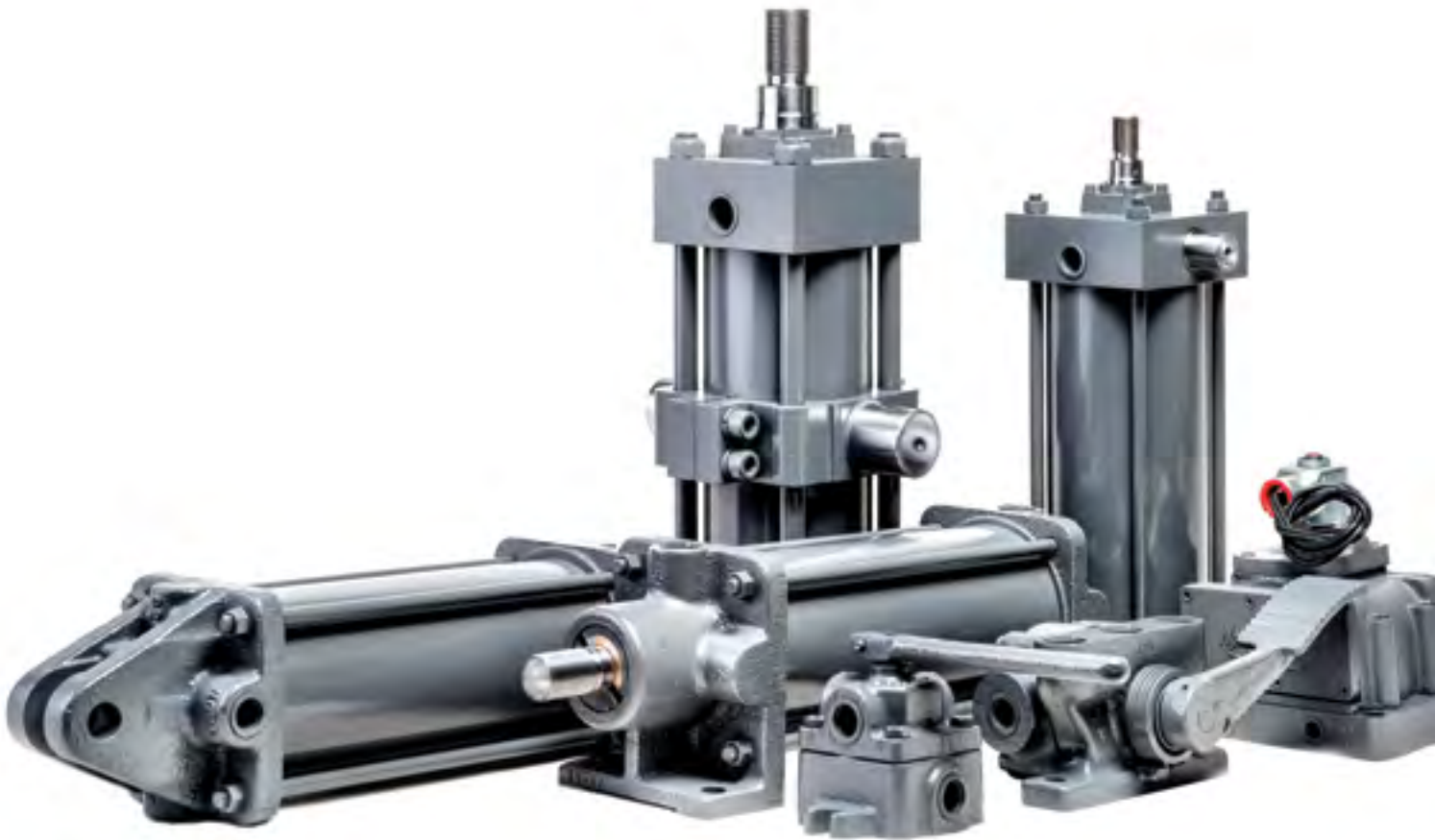

# NOPAK

First in Manufacturing. Engineered to Last.



---

## Cylinders & Valves

Full Line Catalog

Catalog 1000

---



# TABLE OF CONTENTS

## TABLE OF CONTENTS

<b>Class 1, 2, M</b> Low Pressure Cast-Head Cylinders.....	5
<b>Class 1 SVR</b> Severe Service Hydraulic and Pneumatic Cylinders .....	19
<b>Class 3</b> High Pressure Square-Head Cylinders .....	23
<b>Class 5A</b> Low Pressure NFPA Aluminum Cylinders.....	69
<b>Class 6</b> Intermediate Pressure Square-Head Cylinders .....	93
<b>Directional Control Valves</b> Hand, Foot and Solenoid.....	143
<b>Boosters, Intensifiers and Air/Oil Tanks</b> Ram and Piston Type.....	171
<b>Terms and Conditions of Sale</b> .....	189

## TABLE OF CONTENTS

<b>Class 1, 2, M</b> Low Pressure Cast-Head Cylinders.....	5
<b>Class 1 SVR</b> Severe Service Hydraulic and Pneumatic Cylinders .....	19
<b>Class 3</b> High Pressure Square-Head Cylinders .....	23
<b>Class 5A</b> Low Pressure NFPA Aluminum Cylinders.....	69
<b>Class 6</b> Intermediate Pressure Square-Head Cylinders .....	93
<b>Directional Control Valves</b> Hand, Foot and Solenoid.....	143
<b>Boosters, Intensifiers and Air/Oil Tanks</b> Ram and Piston Type.....	171
<b>Terms and Conditions of Sale</b> .....	189



# Class 1, 2, M

Hydraulic and Pneumatic Cylinders

---



# NOPAK

First in Manufacturing. Engineered to Last.

**TABLE OF CONTENTS**

NOPAK Low Pressure Cast Head Cylinders . . . 6

Options, Modifications and Ordering Information . . . . .7

Class 1, 2 & M Cast Head Cylinder Cutaway View. . . . . 8

Cylinder Design and Construction Features . . . 9

    Types of Cushioning Action (Classes 1, 2 and M) . . . . . 9

    Piston Assembly . . . . . 9

    Rod End Detail . . . . . 9

Parallel Base Mounting . . . . .10

Clevis Mounting . . . . . 11

Right Angle Flat Base Mounting. . . . .12

Trunnion Mounting . . . . .14

Class M. . . . .15

Cylinder Force, Air Consumption and Torque Values. . . . .16

Accessories. . . . .17

Replacement Parts . . . . .18

Reed Proximity Switch . . . . .19

**NOPAK LOW PRESSURE CAST HEAD CYLINDERS**

**CLASS 1 CAST HEAD CYLINDERS**

For normal applications where low-cost, rugged air cylinders are required. Our exclusive design has been “user-proven” with over 80 years of experience as the work horse of industry.

**CLASS 2 CAST HEAD CYLINDERS**

For higher operating air pressures and hydraulic use. These cylinders incorporate recessed gasketed tube seals and piston to rod O-ring seals as standard features.

**CLASS M CAST HEAD MILL TYPE CYLINDERS**

These cylinders have all the features of NOPAK Class 2 cylinders plus oversize rods and steel tubing with welded flanges and bolted cylinder heads. See page 15.

**CL1/SVR CAST HEAD/SEVERE SERVICE CYLINDERS**

See the Class 1 SVR Section. These extra-rugged units feature “over-” over-size rods (as compared against competitive models) and extra-heavy duty rod bearing for the most abusive of service.

The aforesaid designs, evolving from the evermore challenging demands for gigantic Mill types, now place NOPAK in the forefront.

We welcome the opportunity to quote your most challenging applications.

PRESSURE RATINGS (PSI) RECOMMENDED MAXIMUM			
AIR		HYDRAULIC	
CYL. DIA.	CLASS 1, 2, M	CLASS 2	CLASS M
1-1/2	250	450	650
2	250	450	650
2-1/2	250	450	650
3	250	450	650
4	250	450	650
5	250	450	450
6	250	450	450
8	250	450	450
10	250	450	450
12	250	450	450
14	250	450	450

APPROXIMATE UNCRATED CLASS 1, 2, M CAST HEAD CYLINDER WEIGHTS (LBS.)													
		CYLINDER BORE	1-1/2	2	2-1/2	3	4	5	6	8	10	12	14
Add Per Inch of Stroke	Zero Stroke		4.5	6.8	10.6	13.5	23.4	30.6	52.2	113	175	321	415
	Class 1, 2		.38	.44	.65	.75	1.1	1.3	1.6	2.7	4.5	5.9	6.5
	Class M		.45	.45	.75	.75	1.2	1.5	2	2.5	4.5	7.1	8.5

# OPTIONS, MODIFICATIONS AND ORDERING INFORMATION

## OPTIONS

### BORE SIZE

The bore size of an air cylinder should be selected to supply from 125% to 200% of the required force. The excess of force versus load will result in a faster cylinder speed assuming there is an adequate supply of air into and out of the cylinder.

The bore size of a hydraulic cylinder should be selected to supply sufficient force to exceed the load by approximately 20%. The cylinder speed is the result of flow into and out of the cylinder. Force tables to aid in cylinder sizing are on page 16.

### MOUNTINGS

Select the cylinder mounting which will keep the line of force as close as possible to the centerline of the piston rod and free of misalignment. This will maximize seal and bearing life.

### DOUBLE ROD END

NOPAK Class 1, 2 and M cylinders when ordered as double rod end are designated by prefixing the model with letter "X." Mounting dimensions may vary from standard because two rod end heads are used. The rod sizes or head models may be interchanged.

### CUSHIONS

Unless specified otherwise NOPAK Class 1, 2 and M cylinders are furnished with self-regulating cushions on both ends. Adjustable cushions or non-cushion cylinders are also available. See page 9.

The purpose of a cushion is to slow up piston speed at the end of the stroke, eliminating shock. The mass to be cushioned should be limited to one-half the cylinder force unless other provisions are made for deceleration or special cushioning.

### SPECIAL MATERIALS AND PLATING

Special materials, metals and/or platings are available for various applications including AWWA Specifications.

## CUSTOM MODIFICATIONS

### STOP TUBES

In long cylinders used on push applications, internal stop tubes may be necessary to prevent excessive bearing wear. When stop tubes are required with a cushioned air cylinder, a dual or wider piston or similar arrangement is recommended to reduce the trapped air volume and provide the necessary cushion back pressure.

### OVERSIZE RODS

An oversize piston rod, 1/4" larger than normal, is available for all Class 1 and Class 2 cylinder diameters except for the 8" which has an oversize rod as standard. Specify rod diameter when ordering. The rod end threading, the rod extension, and related dimensions are shown in Table 2.

The oversize rod is a standard feature on NOPAK Class M mill type cylinders.

### PISTON ROD EXTENSION AND ROD THREADING

Longer than standard piston rod extensions may be required to accommodate load fastening. Depending upon the details of rod engagement to load, special threading on rod end configuration may be required.

### CYLINDER PORTS

To increase cylinder speed, increased fluid volume is necessary. This can be done by using enlarged or additional ports.

## HOW TO ORDER

### All orders should include the following information:

1. Class of cylinder (1, 2 or M).
2. Bore or cylinder diameter size.
3. Stroke length in inches.
4. NOPAK model.
5. Type of cushioning.
6. Piston rod diameter and type of rod end threading as 1, 3, 5 or special.
7. Operating medium (air, oil or water).

### Also specify:

1. Extreme temperatures (below -20°F or above +250°F).
2. Minimum pressure (if less than 20 PSI).
3. Type of fluid (if other than air, oil or water).
4. Unusual operating conditions.

**NOTE:** Dimensions in inches of ALL Piston Rod Extensions must be taken with the rod retracted. For other than standard piston rod end length dimensions, locate the extreme outboard end of the piston rod in relation to the mounting dimensions of that particular model. Variations in length should be indicated in reference to this dimension. (Related to "C" dimension designation.)

### ORDERING CODE EXAMPLE

**CL1 - 4 x 12 - E - AS - 1.00 - 1 - OPT**

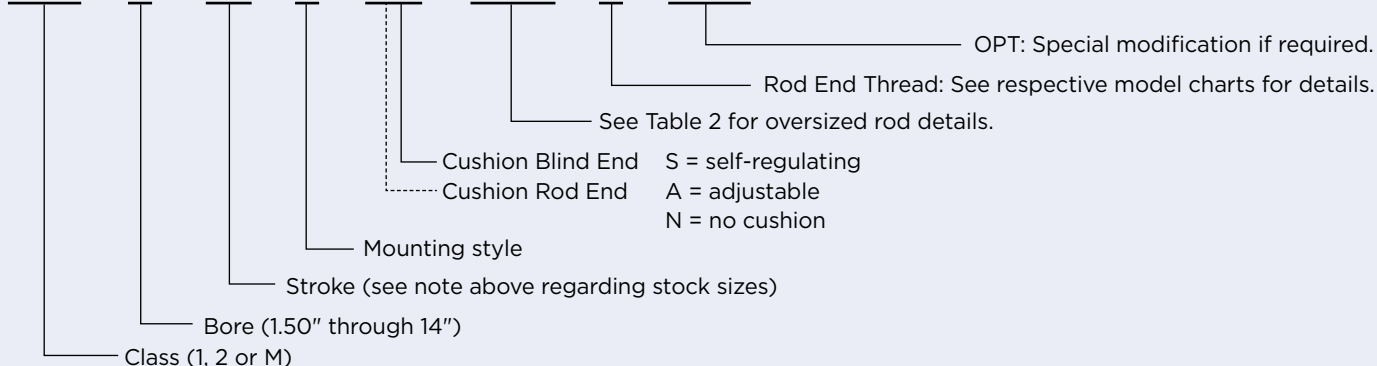

## CLASS 1, 2 & M CAST HEAD CYLINDER CUTAWAY VIEW

Sectional view of a NOPAK Double-Acting Cylinder with Adjustable Cushions. It graphically illustrates 8 other features of NOPAK Cylinder construction which contribute to smooth, efficient performance under severe operating conditions.

### MOUNTINGS

Classes 1, 2 and M are available in the five standard mountings designated as Models A, C, D, E and F, illustrated on pages 10 to 15 inclusive.

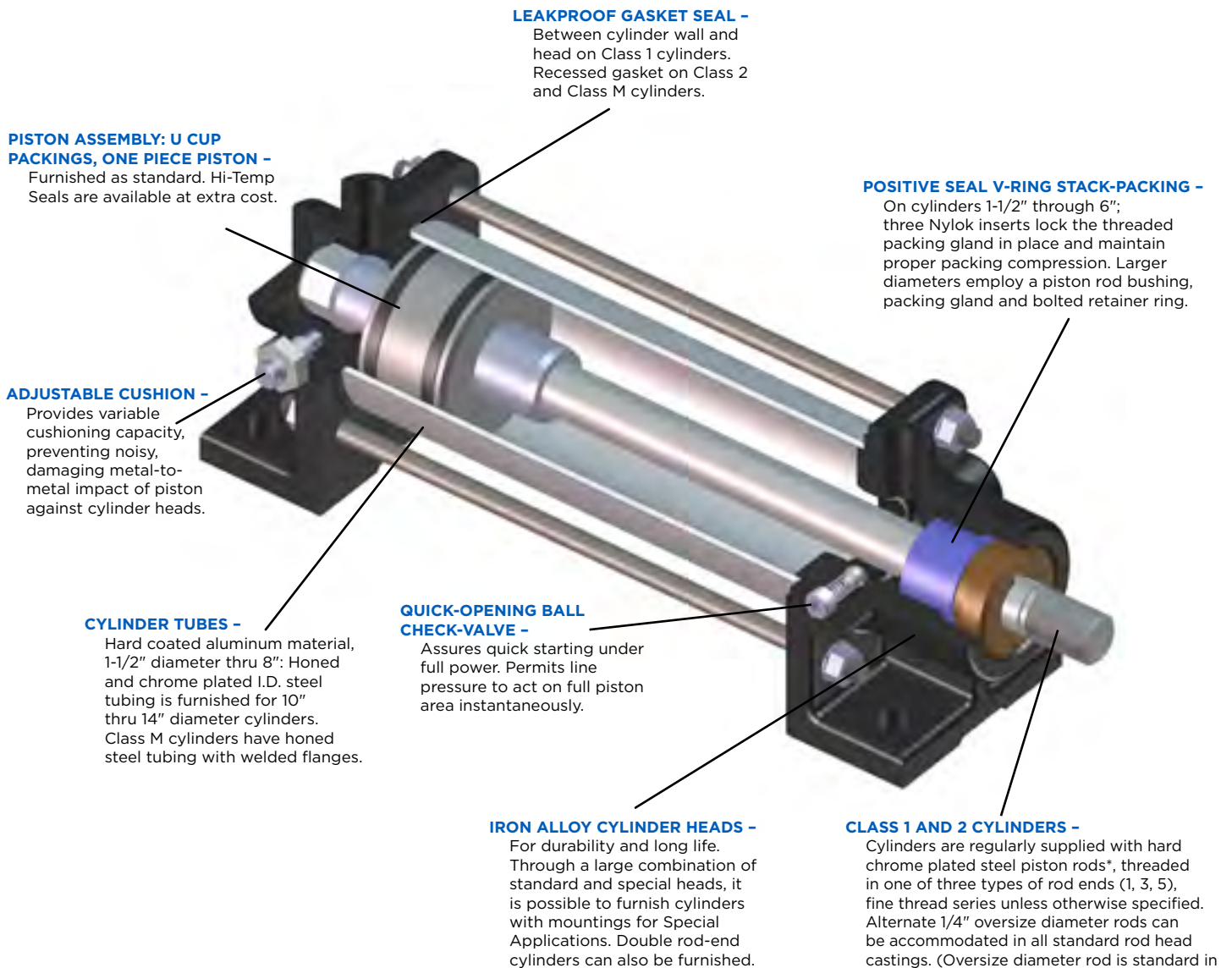

\* Standard piston rod material is high tensile 100,000 PSI minimum yield, ground, polished, and flash chrome plated .0003/0.005 to provide a hard long-wearing surface with low friction. Consult factory for other than air applications.



# CYLINDER DESIGN AND CONSTRUCTION FEATURES

## TYPES OF CUSHIONING ACTION (CLASSES 1, 2 AND M)

### SELF-REGULATING CUSHION TYPE (Operates Automatically)

The self-regulating cylinder head requires no adjustment. Once the cylinder is assembled, its operation is entirely automatic. As the cushion sleeve enters the bore in the cylinder head, the air or fluid is trapped between the piston and the cylinder head, forming a pneumatic or hydraulic cushion.

Predetermined taper on the cushion sleeve and tolerance between it and bore in the cylinder head provide the self-regulating, positive cushion action. This maximum cushion effect remains constant at all times without needing adjustment.

### ADJUSTABLE CUSHION TYPE

The adjustable cushion is often desirable where load relations to cylinder capacity are apt to vary a great deal. After the cushion is adjusted, by means of the needle valve, the speed at which the piston continues to the end of its stroke is governed by the foregoing adjustment.

### NON-CUSHIONED CYLINDERS

NOPAK cylinders can also be furnished with non-cushioned stroke, providing motion at constant speed for full travel. As there is no provision for cushioning, this type is recommended only where the piston speed is very slow, where the stroke is very short, or where the piston is stopped on the work before it reaches the end of full stroke.

#### One or Both Ends May Be Cushioned

Standardized design and interchangeable components within each class of construction permit the cushioning of one or both ends, with either Adjustable or Self-Regulating Cushions.

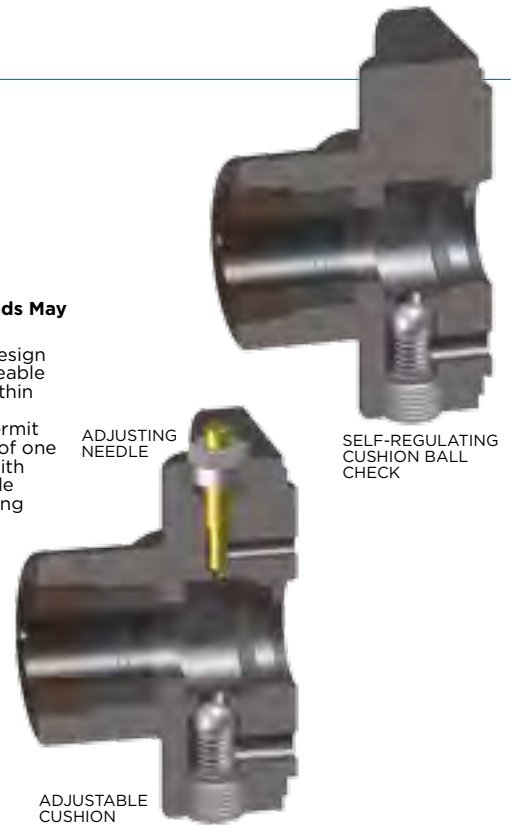

## PISTON ASSEMBLY

### U CUP PACKING

U Cup packings, self-sealing by line pressure, are furnished as standard equipment in Class 1, 2 and M Mill Type cylinders. Different types of cups are recommended for different types of service, as follows:

1. **Type A** - For low pressure air, oil or water. (Water, Glycol, Fire Resistant Fluids.) Temperature -20°F to +225°F.
2. **Type B** - Higher Temperatures -20°F to +325°F oil or air service. (Phosphate, Ester, Fire Resistant Fluids.)

The above is a simplified statement for general purpose and average conditions. Information on specific media and temperatures exceeding the above ratings should be referred to the NOPAK Engineering Department.

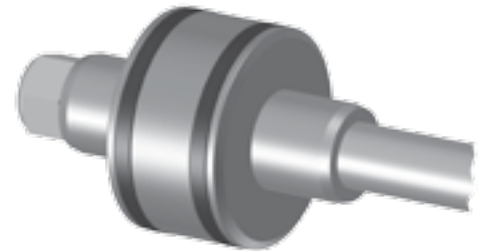

## ROD END DETAIL

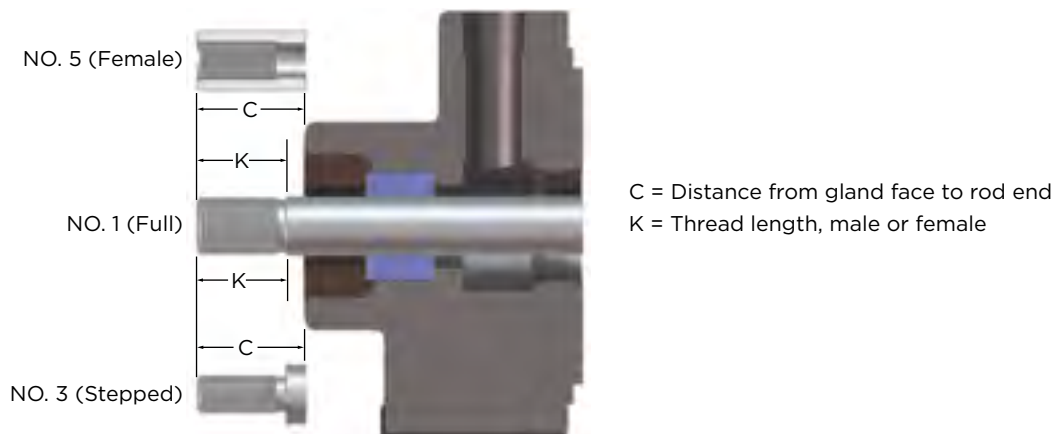

**MODEL A**



**CLASS 1 or 2** Double Acting Cylinder

**FOR 16" DIAMETER AND LARGER, REFER TO THE CLASS 6 SECTION.**

End view illustrates 8 tie rod spacing incorporated in the 10", 12" and 14" bore sizes. See dimension L.

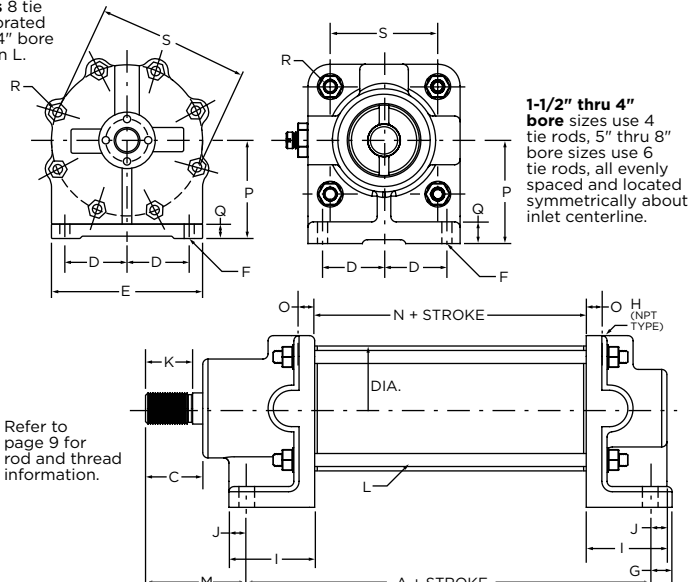

**1-1/2" thru 4" bore sizes use 4 tie rods, 5" thru 8" bore sizes use 6 tie rods, all evenly spaced and located symmetrically about inlet centerline.**

Refer to page 9 for rod and thread information.

Model "A" is used primarily in applications requiring straight-line push-pull motion where cylinder can be mounted on a flat surface. Intermediate supports can be furnished in cases where ratio of cylinder stroke to bore is large, to prevent excessive deflection and resulting wear on cups and packings.

**Table 1** BASIC DIMENSIONS MODEL A CLASS 1 OR 2

- = A 1/4" oversize rod, standard in the 8" bore size, can be furnished using standard head castings. Rod end extension and related dimensions will therefore vary accordingly. See Table 2. Dimensions shown in this catalog may be altered without notice.
- = These are rough dimensions and should not be used for locating purposes.

BORE	ROD• DIA.	NO. 1 THREAD	NO. 3 THREAD	NO. 5 THREAD (FEMALE)	A	C	D	E■	F	G	H	I■	J	K	L	M	N	O	P	Q	R	S
1-1/2	5/8	5/8-18	3/8-24	1/2-20	4-1/8	1-1/8	7/8	2-3/4	13/32	1/2	1/4	1-3/4	7/16	7/8	(4) 5/16	1-7/8	1-3/8	5/8	1-3/4	3/8	3/8	2-5/8
2	5/8	5/8-18	1/2-20	1/2-20	4-3/8	1-1/8	1	3	13/32	1/2	1/4	2	1/2	7/8	(4) 5/16	1-3/4	1-3/8	5/8	2-1/8	1/2	1/2	2-7/8
2-1/2	3/4	3/4-16	1/2-20	1/2-20	4-3/4	1-3/8	1-1/8	3-1/2	17/32	5/8	3/8	2-1/8	5/8	1-1/8	(4) 3/8	2-5/8	1-3/4	5/8	2-3/8	1/2	1/2	3-1/2
3	3/4	3/4-16	5/8-18	1/2-20	4-7/8	1-3/8	1-5/16	3-7/8	17/32	3/4	3/8	2-1/8	5/8	1-1/8	(4) 3/8	2-9/16	1-3/4	3/4	2-1/2	1/2	1/2	3-7/8
4	1	1-14	3/4-16	5/8-18	5-1/2	1-3/4	1-15/16	4-7/8	17/32	7/8	1/2	2-3/8	5/8	1-1/2	(4) 1/2	3-3/8	2	1	3	1/2	5/8	5-1/8
5	1	1-14	3/4-16	5/8-18	5-3/4	1-3/4	2-3/16	5-5/8	17/32	7/8	1/2	2-1/2	5/8	1-1/2	(6) 1/2	3-1/4	2	1	3-3/4	5/8	1/2	6-1/8
6	1-1/4	1-1/4-12	1-14	3/4-16	5-5/8	2-1/8	2-15/16	7-1/8	17/32	1-5/8	3/4	2-1/8	5/8	1-7/8	(6) 1/2	4-1/4	2-5/8	1	4-7/16	5/8	5/8	7-1/8
8	1-3/4	1-3/4-12	1-1/2-12	1-14	7-1/4	2-1/2	4-1/8	9-3/4	21/32	3/4	1	2-1/2	3/4	2-1/4	(6) 5/8	4-7/8	3-1/2	1-1/8	6-3/8	3/4	11/16	9-1/2
10	2	2-12	1-1/2-12	1-1/4-12	8-3/8	3-1/4	4-9/16	11-5/8	25/32	1-3/4	1-1/4	3-5/8	1-1/4	3	(8) 3/4	5-7/8	3-5/8	1-1/8	7-1/2	1	1	11-5/8
12	2-1/2	2-1/2-12	2-12	1-1/2-12	10	4	5-1/4	14-3/4	1-1/16	2-3/8	1-1/2	5	1-7/8	3-3/4	(8) 7/8	7-1/8	3-3/4	1-3/8	9	1-1/4	1-1/8	14-3/4
14	2-3/4	2-3/4-12	2-1/2-12	1-3/4-12	10-1/4	4	6-1/2	17	1-5/16	3	2	5-1/4	2	3-3/4	(8) 7/8	7-1/8	3-3/4	2	10-1/4	1-1/2	1-1/8	17

**Table 2** DIMENSION CHANGES FOR 1/4" OVERSIZE ROD DIAMETER & CLASS M

BORE	ROD• DIA.	NO. 1 THREAD	NO. 3 THREAD	NO. 5 THREAD (FEMALE)	A	C NO. 1 THREAD	C NO. 3 & 5 THREAD	K NO. 1 THREAD	K NO. 3 THREAD	K NO. 5 THREAD (FEMALE)	M NO. 1 THREAD	M NO. 3 THREAD	M NO. 5 THREAD (FEMALE)
1-1/2	7/8	7/8-14	5/8-18	1/2-20	4-1/8	1-1/2	1-1/8	1-1/4	7/8	7/8	2-1/4	1-7/8	1-7/8
2	7/8	7/8-14	5/8-18	1/2-20	4-3/8	1-1/2	1-1/8	1-1/4	7/8	7/8	2-1/8	1-3/4	1-3/4
2-1/2	1	1-14	3/4-16	1/2-20	4-3/4	1-3/4	1-3/8	1-1/2	1-1/8	7/8	3	2-5/8	2-5/8
3	1	1-14	3/4-16	1/2-20	4-7/8	1-3/4	1-3/8	1-1/2	1-1/8	7/8	2-15/16	2-9/16	2-9/16
4	1-1/4	1-1/4-12	1-14	5/8-18	5-1/2	2-1/8	1-3/4	1-7/8	1-1/2	1-1/8	3-3/4	3-3/8	3-3/8
5	1-1/4	1-1/4-12	1-14	5/8-18	5-3/4	2-1/8	1-3/4	1-7/8	1-1/2	1-1/8	3-5/8	3-1/4	3-1/4
6	1-1/2	1-1/2-12	1-1/4-12	3/4-16	5-5/8	2-1/2	2-1/8	2-1/4	1-7/8	1-1/4	4-5/8	4-1/4	4-1/4
8	1-3/4	1-3/4-12	1-1/2-12	1-14	7-1/4	2-1/2	2-1/2	2-1/4	2-1/4	2-1/4	4-7/8	4-7/8	4-7/8
10	2-1/4	2-1/4-12	2-12	1-1/4-12	8-3/8	3-5/8	3-1/4	3-3/8	3	2	6-1/4	5-7/8	5-7/8
12	2-3/4	2-3/4-12	2-1/2-12	1-1/2-12	10	4-3/8	4	4-1/8	3-3/4	2-3/8	7-1/2	7-1/8	7-1/8
14	3	3-12	2-1/2-12	1-3/4-12	10-1/4	4-3/4	4	4-1/2	3-3/4	2-3/4	7-7/8	7-1/8	7-1/8

## MODEL E



CLASS 1 or 2 Double Acting Cylinder

End view illustrates 8 tie rod spacing incorporated in the 10", 12" and 14" bore sizes. See dimension L.

1-1/2" thru 4" bore sizes use 4 tie rods, 5" thru 8" bore sizes use 6 tie rods, all evenly spaced and located symmetrically about inlet centerline.

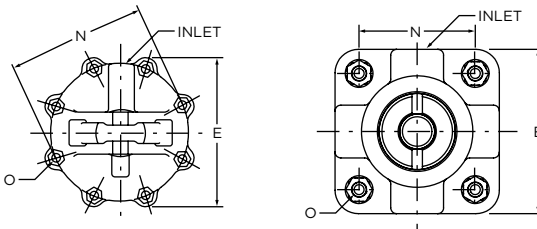

Refer to page 9 for rod and thread information.

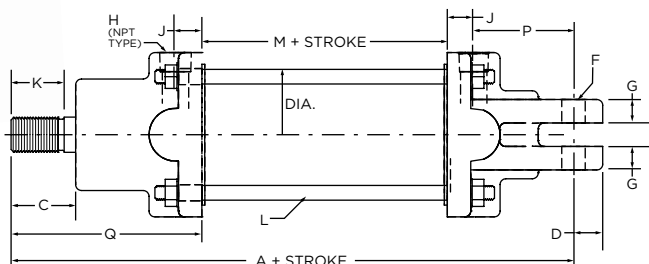

**FOR 16" DIAMETER AND LARGER, REFER TO THE CLASS 6 SECTION.**

Model E is designed expressly for use in hoist service or where articulated or oscillating movement is required. It is often attached to ceiling, beam or other overhead surfaces, with rod end down, but is also used in the opposite position for upward pushing or tilting operations.

**Table 1** BASIC DIMENSIONS MODEL E CLASS 1 OR 2

• = A 1/4" oversize rod, standard in the 8" bore size, can be furnished using standard head castings. Rod end extension and related dimensions will therefore vary accordingly. See Table 2. Dimensions shown in this catalog may be altered without notice.

BORE	ROD·DIA.	NO. 1 THREAD	NO. 3 THREAD	NO. 5 THREAD (FEMALE)	A	C	D	E	F	G	H	I	J	K	L	M	N	O	P	Q
1-1/2	5/8	5/8-18	3/8-24	1/2-20	6-3/4	1-1/8	1/2	2-3/4	3/8	3/8	1/4	1/2	5/8	7/8	(4) 5/16	1-3/8	2-5/8	3/8	1-1/2	3-1/4
2	5/8	5/8-18	1/2-20	1/2-20	7-1/4	1-1/8	5/8	3	1/2	1/2	1/4	1/2	5/8	7/8	(4) 5/16	1-3/8	2-7/8	1/2	2	3-1/4
2-1/2	3/4	3/4-16	1/2-20	1/2-20	8-5/8	1-3/8	5/8	3-1/2	1/2	1/2	3/8	1/2	5/8	1-1/8	(4) 3/8	1-3/4	3-1/2	1/2	2-1/8	4-1/8
3	3/4	3/4-16	5/8-18	1/2-20	8-7/8	1-3/8	5/8	3-3/4	1/2	1/2	3/8	1/2	3/4	1-1/8	(4) 3/8	1-3/4	3-7/8	1/2	2-5/16	4-1/8
4	1	1-14	3/4-16	5/8-18	10-3/4	1-3/4	7/8	4-7/8	3/4	3/4	1/2	3/4	1	1-1/2	(4) 1/2	2	5-1/8	5/8	2-5/8	5-1/8
5	1	1-14	3/4-16	5/8-18	10-7/8	1-3/4	7/8	6-3/8	3/4	3/4	1/2	3/4	1	1-1/2	(6) 1/2	2	6-1/8	1/2	2-3/4	5-1/8
6	1-1/4	1-1/4-12	1-14	3/4-16	12-3/4	2-1/8	1-1/8	7-1/4	7/8	1	3/4	1	1	1-7/8	(6) 1/2	2-5/8	7-1/8	5/8	3-3/8	5-3/4
8	1-3/4	1-3/4-12	1-1/2-12	1-14	14	2-1/2	1-1/4	9-5/8	1	1	1	1-1/4	1-1/8	2-1/4	(6) 5/8	3-1/2	9-1/2	11/16	2-5/8	6-3/4
10	2	2-12	1-1/2-12	1-1/4-12	17-3/4	3-1/4	1-1/2	12-3/4	1-1/4	1-1/4	1-1/4	1-1/2	1-1/8	3	(8) 3/4	3-5/8	11-5/8	1	4-3/4	8-1/4
12	2-1/2	2-1/2-12	2-12	1-1/2-12	21-3/4	4	1-3/4	15-7/8	1-1/2	1-1/2	1-1/2	2	1-3/8	3-3/4	(8) 7/8	3-3/4	14-3/4	1-1/8	6-3/8	10-1/4
14	2-3/4	2-3/4-12	2-1/2-12	1-3/4-12	22-7/8	4	2	17-3/4	1-3/4	1-3/4	2	2-1/2	2	3-3/4	(8) 7/8	3-3/4	17	1-1/8	6-3/4	10-3/8

**Table 2** DIMENSION CHANGES FOR 1/4" OVERSIZE ROD DIAMETER & CLASS M

BORE	ROD·DIA.	NO. 1 THREAD	NO. 3 THREAD	NO. 5 THREAD (FEMALE)	A NO. 1 THREAD	A NO. 3 & 5 THREAD	C NO. 1 THREAD	C NO. 3 & 5 THREAD	K NO. 1 THREAD	K NO. 3 THREAD	K NO. 5 THREAD (FEMALE)	Q NO. 1 THREAD	Q NO. 3 THREAD	Q NO. 5 THREAD (FEMALE)
1-1/2	7/8	7/8-14	5/8-18	1/2-20	7-1/8	6-3/4	1-1/2	1-1/8	1-1/4	7/8	7/8	2-1/4	3-1/4	3-1/4
2	7/8	7/8-14	5/8-18	1/2-20	7-5/8	7-1/4	1-1/2	1-1/8	1-1/4	7/8	7/8	2-1/8	3-1/4	3-1/4
2-1/2	1	1-14	3/4-16	1/2-20	9	8-5/8	1-3/4	1-3/8	1-1/2	1-1/8	7/8	3	4-1/8	4-1/8
3	1	1-14	3/4-16	1/2-20	9-1/4	8-7/8	1-3/4	1-3/8	1-1/2	1-1/8	7/8	2-15/16	4-1/8	4-1/8
4	1-1/4	1-1/4-12	1-14	5/8-18	11-1/8	10-3/4	2-1/8	1-3/4	1-7/8	1-1/2	1-1/8	3-3/4	5-1/8	5-1/8
5	1-1/4	1-1/4-12	1-14	5/8-18	11-1/4	10-7/8	2-1/8	1-3/4	1-7/8	1-1/2	1-1/8	3-5/8	5-1/8	5-1/8
6	1-1/2	1-1/2-12	1-1/4-12	3/4-16	13-1/8	12-3/4	2-1/2	2-1/8	2-1/4	1-7/8	1-1/4	4-5/8	5-3/4	5-3/4
8	1-3/4	1-3/4-12	1-1/2-12	1-14	14	14	2-1/2	2-1/2	2-1/4	2-1/4	2-1/4	4-7/8	6-3/4	6-3/4
10	2-1/4	2-1/4-12	2-12	1-1/4-12	18-1/8	17-3/4	3-5/8	3-1/4	3-3/8	3	2	6-1/4	8-1/4	8-1/4
12	2-3/4	2-3/4-12	2-1/2-12	1-1/2-12	22-1/8	21-3/4	4-3/8	4	4-1/8	3-3/4	2-3/8	7-1/2	10-1/4	10-1/4
14	3	3-12	2-1/2-12	1-3/4-12	23-5/8	22-7/8	4-3/4	4	4-1/2	3-3/4	2-3/4	7-7/8	10-3/8	10-3/8

**MODEL C BLANK END MOUNTING**

**CLASS 1 or 2**  
Double Acting Cylinder



Refer to page 9 for rod and thread information.

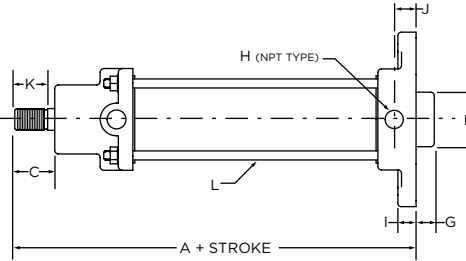

**FOR 16" DIAMETER AND LARGER, REFER TO THE CLASS 6 SECTION.**

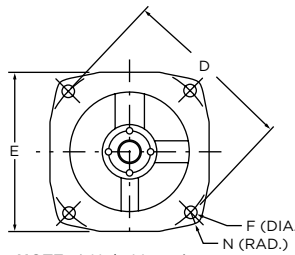

**NOTE:** 4-Hole Mounting is used on Model C Cylinders from 4" to 14" in diameter.

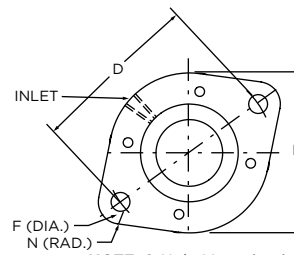

**NOTE:** 2-Hole Mounting is used on Model C Cylinders from 1-1/2" to 3" in diameter.

Model C may be mounted on any flat base with provision for protruding cushion boss\*. It is used in applications of upward pushing power; also for cantilever action when mounted at right angles to a wall or other vertical surface.

\* Flush mounting available at extra charge on blank end, if not cushioned.

**Table 1** BASIC DIMENSIONS MODEL C CLASS 1 OR 2

- = A 1/4" oversize rod, standard in the 8" bore size, can be furnished using standard head castings. Rod end extension and related dimensions will therefore vary accordingly. See Table 2. Dimensions shown in this catalog may be altered without notice.
- = These are rough dimensions and should not be used for locating purposes. Allow approximately 1/4" for clearance. Can be machined at extra charge if specified.

BORE	ROD• DIA.	NO. 1 THREAD	NO. 3 THREAD	NO. 5 THREAD (FEMALE)	A	C	D	E■	F	G	H	I	J	K	L	M■	N
1-1/2	5/8	5/8-18	3/8-24	1/2-20	5-3/4	1-1/8	3-1/4	3-3/8	13/32	3/8	1/4	1/2	1/2	7/8	(4) 5/16	1-1/2	1/2
2	5/8	5/8-18	1/2-20	1/2-20	5-7/8	1-1/8	3-3/4	3-7/8	13/32	5/8	1/4	5/8	5/8	7/8	(4) 5/16	1-3/4	1/2
2-1/2	3/4	3/4-16	1/2-20	1/2-20	7-1/4	1-3/8	4-3/4	4-1/2	17/32	5/8	3/8	5/8	3/4	1-1/8	(4) 3/8	1-7/8	5/8
3	3/4	3/4-16	5/8-18	1/2-20	7-3/8	1-3/8	5-1/4	4-7/8	17/32	3/4	3/8	5/8	3/4	1-1/8	(4) 3/8	2-1/8	5/8
4	1	1-14	3/4-16	5/8-18	8-7/8	1-3/4	7-3/4	6-3/4	17/32	7/8	1/2	5/8	3/4	1-1/2	(4) 1/2	2-5/8	5/8
5	1	1-14	3/4-16	5/8-18	8-7/8	1-3/4	7-3/4	7-1/4	17/32	7/8	1/2	3/4	7/8	1-1/2	(6) 1/2	2-5/8	5/8
6	1-1/4	1-1/4-12	1-14	3/4-16	10-1/2	2-1/8	9	8-3/8	17/32	1-1/8	3/4	3/4	7/8	1-7/8	(6) 1/2	3	5/8
8	1-3/4	1-3/4-12	1-1/2-12	1-14	12-5/8	2-1/2	10-3/4	10-7/8	25/32	-	1	7/8	1-1/4	2-1/4	(6) 5/8	-	7/8
10	2	2-12	1-1/2-12	1-1/4-12	14-3/4	3-1/4	13-1/4	12-1/2	29/32	2	1-1/4	1-1/8	1-1/8	3	(8) 3/4	4-1/2	1
12	2-1/2	2-1/2-12	2-12	1-1/2-12	17-7/8	4	17-1/2	16	1-1/16	2-1/2	1-1/2	1-1/2	1-3/8	3-3/4	(8) 7/8	5-1/2	1-1/4
14	2-3/4	2-3/4-12	2-1/2-12	1-3/4-12	18-3/8	4	20	18-3/4	1-5/16	2-1/4	2	1-3/4	2	3-3/4	(8) 7/8	5-7/8	1-1/2

**Table 2** DIMENSION CHANGES FOR 1/4" OVERSIZE ROD DIAMETER & CLASS M

BORE	ROD• DIA.	A NO. 1 THREAD	A NO. 3 & 5 THREAD	NO. 1 THREAD	NO. 3 THREAD	NO. 5 THREAD (FEMALE)	C NO. 1 THREAD	C NO. 3 & 5 THREAD	K NO. 1 THREAD	K NO. 3 THREAD	K NO. 5 THREAD (FEMALE)
1-1/2	7/8	6-1/8	5-3/4	7/8-14	5/8-18	1/2-20	1-1/2	1-1/8	1-1/4	7/8	7/8
2	7/8	6-1/4	5-7/8	7/8-14	5/8-18	1/2-20	1-1/2	1-1/8	1-1/4	7/8	7/8
2-1/2	1	7-5/8	7-1/4	1-14	3/4-16	1/2-20	1-3/4	1-3/8	1-1/2	1-1/8	7/8
3	1	7-3/4	7-3/8	1-14	3/4-16	1/2-20	1-3/4	1-3/8	1-1/2	1-1/8	7/8
4	1-1/4	9-1/4	8-7/8	1-1/4-12	1-14	5/8-18	2-1/8	1-3/4	1-7/8	1-1/2	1-1/8
5	1-1/4	9-1/4	8-7/8	1-1/4-12	1-14	5/8-18	2-1/8	1-3/4	1-7/8	1-1/2	1-1/8
6	1-1/2	10-7/8	10-1/2	1-1/2-12	1-1/4-12	3/4-16	2-1/2	2-1/8	2-1/4	1-7/8	1-1/4
8	1-3/4	12-5/8	12-5/8	1-3/4-12	1-1/2-12	1-14	2-1/2	2-1/2	2-1/4	2-1/4	2-1/4
10	2-1/4	15-1/8	14-3/4	2-1/4-12	2-12	1-1/4-12	3-5/8	3-1/4	3-3/8	3	2
12	2-3/4	18-1/4	17-7/8	2-3/4-12	2-1/2-12	1-1/2-12	4-3/8	4	4-1/8	3-3/4	2-3/8
14	3	19-1/8	18-3/8	3-12	2-1/2-12	1-3/4-12	4-3/4	4	4-1/2	3-3/4	2-3/4

# RIGHT ANGLE FLAT BASE MOUNTING

## MODEL D ROD END MOUNTING

**CLASS 1 or 2**  
Double Acting Cylinder

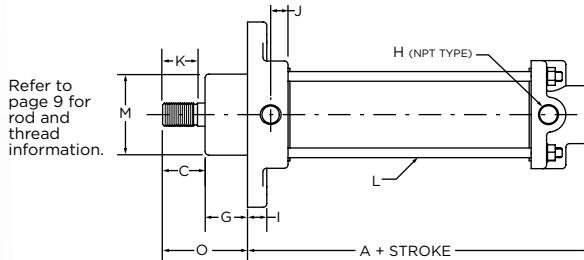

**FOR 16" DIAMETER AND LARGER, REFER TO THE CLASS 6 SECTION.**

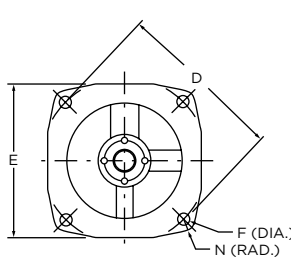

**NOTE: 4-Hole Mounting** is used on Model D Cylinders from 4" to 14" in diameter.

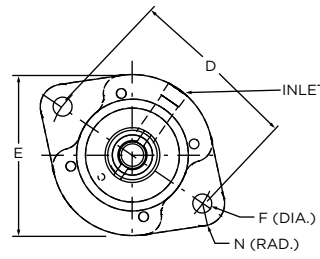

**NOTE: 2-Hole Mounting** is used on Model D Cylinders from 1-1/2" to 3" in diameter.

Model D is similar in construction to Model C, except that the piston rod is extended through the mounting base. It may be mounted on any flat surface in which an opening can be provided for the protruding cushion boss and extension of the rod. It is used extensively in applications of inward pulling power.

**Table 1** BASIC DIMENSIONS MODEL D CLASS 1 OR 2

- = A 1/4" oversize rod, standard in the 8" bore size, can be furnished using standard head castings. Rod end extension and related dimensions will therefore vary accordingly. See Table 2. Dimensions shown in this catalog may be altered without notice.
- = These are rough dimensions, except on the 8" diameter cylinder. For locating purposes allow approximately 1/4" for clearance. Can be machined 1/4" smaller than diameter shown at extra charge. The 8" diameter includes a machined hub 4.250-.005 as standard.

BORE	ROD• DIA.	NO. 1 THREAD	NO. 3 THREAD	NO. 5 THREAD (FEMALE)	A	C	D	E■	F	G	H	I	J	K	L	M■	N	O
1-1/2	5/8	5/8-18	3/8-24	1/2-20	4	1-1/8	3-1/4	3-3/8	13/32	1	1/4	1/2	1/2	7/8	(4) 5/16	2	1/2	2-1/8
2	5/8	5/8-18	1/2-20	1/2-20	4-1/2	1-1/8	3-3/4	3-7/8	13/32	7/8	1/4	5/8	5/8	7/8	(4) 5/16	2	1/2	2
2-1/2	3/4	3/4-16	1/2-20	1/2-20	5-1/8	1-3/8	4-3/4	4-1/2	17/32	1-3/8	3/8	5/8	3/4	1-1/8	(4) 3/8	2-5/8	5/8	2-3/4
3	3/4	3/4-16	5/8-18	1/2-20	5-1/2	1-3/8	5-1/4	4-7/8	17/32	1-1/4	3/8	5/8	3/4	1-1/8	(4) 3/8	2-5/8	5/8	2-5/8
4	1	1-14	3/4-16	5/8-18	6-1/2	1-3/4	7-3/4	6-3/4	17/32	1-5/8	1/2	5/8	3/4	1-1/2	(4) 1/2	3	5/8	3-3/8
5	1	1-14	3/4-16	5/8-18	6-5/8	1-3/4	7-3/4	7-1/4	17/32	1-1/2	1/2	3/4	7/8	1-1/2	(6) 1/2	3	3/4	3-1/4
6	1-1/4	1-1/4-12	1-14	3/4-16	7-3/4	2-1/8	9	8-1/4	17/32	1-5/8	3/4	3/4	1	1-7/8	(6) 1/2	3-1/2	5/8	3-3/4
8	1-3/4	1-3/4-12	1-1/2-12	1-14	8-1/8	2-1/2	10-3/4	10-7/8	25/32	1-7/8	1	7/8	1-1/4	2-1/4	(6) 5/8	4-1/4	7/8	4-3/8
10	2	2-12	1-1/2-12	1-1/4-12	10-3/4	3-1/4	13-1/4	12-1/2	29/32	2	1-1/4	1-1/8	1-1/8	3	(8) 3/4	4-1/2	1	5-1/4
12	2-1/2	2-1/2-12	2-12	1-1/2-12	13-1/8	4	17-1/2	16	1-1/16	2-3/8	1-1/2	1-1/2	1-3/8	3-3/4	(8) 7/8	5-1/2	1-1/4	6-3/8
14	2-3/4	2-3/4-12	2-1/2-12	1-3/4-12	14-1/4	4	20	18-3/4	1-5/16	2-1/8	2	1-3/4	2	3-3/4	(8) 7/8	5-7/8	1-1/2	6-1/8

**Table 2** DIMENSION CHANGES FOR 1/4" OVERSIZE ROD DIAMETER & CLASS M

BORE	ROD• DIA.	NO. 1 THREAD	NO. 3 THREAD	NO. 5 THREAD (FEMALE)	A	C NO. 1 THREAD	C NO. 3 & 5 THREAD	K NO. 1 THREAD	K NO. 3 THREAD	K NO. 5 THREAD (FEMALE)	O NO. 1 THREAD	O NO. 3 THREAD	O NO. 5 THREAD (FEMALE)
1-1/2	7/8	7/8-14	5/8-18	1/2-20	4	1-1/2	1-1/8	1-1/4	7/8	7/8	2-1/2	2-1/8	2-1/8
2	7/8	7/8-14	5/8-18	1/2-20	4-1/2	1-1/2	1-1/8	1-1/4	7/8	7/8	2-3/8	2	2
2-1/2	1	1-14	3/4-16	1/2-20	5-1/8	1-3/4	1-3/8	1-1/2	1-1/8	7/8	3-1/8	2-3/4	2-3/4
3	1	1-14	3/4-16	1/2-20	5-1/2	1-3/4	1-3/8	1-1/2	1-1/8	7/8	3	2-5/8	2-5/8
4	1-1/4	1-1/4-12	1-14	5/8-18	6-1/2	2-1/8	1-3/4	1-7/8	1-1/2	1-1/8	3-3/4	3-3/8	3-3/8
5	1-1/4	1-1/4-12	1-14	5/8-18	6-5/8	2-1/8	1-3/4	1-7/8	1-1/2	1-1/8	3-5/8	3-1/4	3-1/4
6	1-1/2	1-1/2-12	1-1/4-12	3/4-16	7-3/4	2-1/2	2-1/8	2-1/4	1-7/8	1-1/4	4-1/8	3-3/4	3-3/4
8	1-3/4	1-3/4-12	1-1/2-12	1-14	8-1/8	2-1/2	2-1/2	2-1/4	2-1/4	2-1/4	4-3/8	4-3/8	4-3/8
10	2-1/4	2-1/4-12	2-12	1-1/4-12	10-3/4	3-5/8	3-1/4	3-3/8	3	2	5-5/8	5-1/4	5-1/4
12	2-3/4	2-3/4-12	2-1/2-12	1-1/2-12	13-1/8	4-3/8	4	4-1/8	3-3/4	2-3/8	6-3/4	6-3/8	6-3/8
14	3	3-12	2-1/2-12	1-3/4-12	14-1/4	4-3/4	4	4-1/2	3-3/4	2-3/4	6-7/8	6-1/8	6-1/8

**MODEL F**

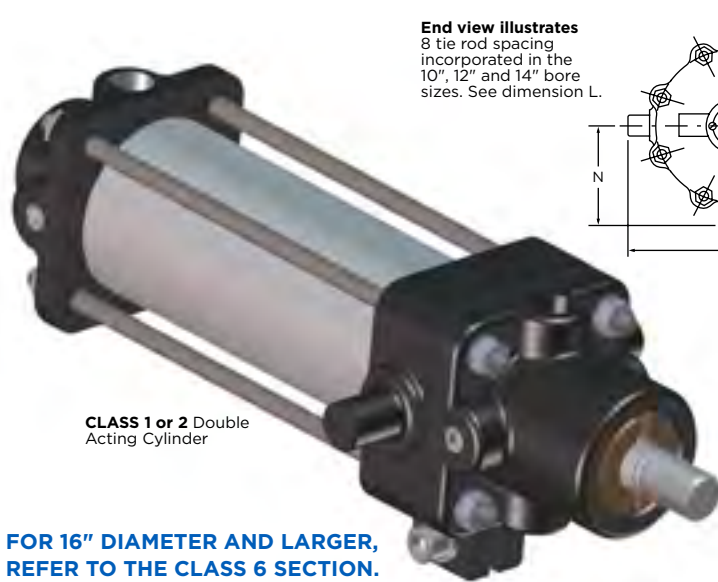

End view illustrates 8 tie rod spacing incorporated in the 10", 12" and 14" bore sizes. See dimension L.

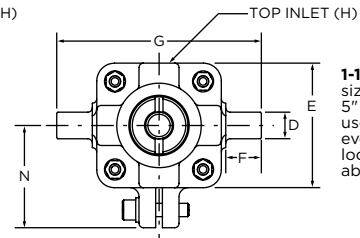
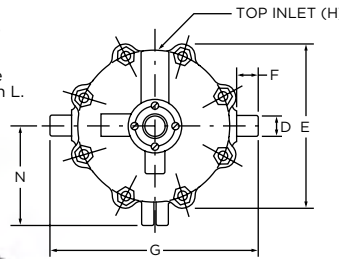

1-1/2" thru 4" bore sizes use 4 tie rods, 5" thru 8" bore sizes use 6 tie rods, all evenly spaced and located symmetrically about inlet centerline.

Refer to page 9 for rod and thread information.

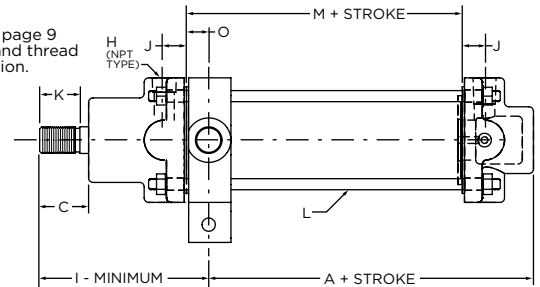

**FOR 16" DIAMETER AND LARGER, REFER TO THE CLASS 6 SECTION.**

The Model F Trunnion Mounting provides smooth, dependable cylinder power where oscillating movement is necessary in connection with heavy side thrust. Trunnion location is indicated by dimension "I," which is minimum and furnished as shown unless otherwise specified; it may be increased within limits of cylinder tubing length.

**NOTE:** Model F available without trunnion - designated as Model H.

**Table 1** BASIC DIMENSIONS MODEL F CLASS 1 OR 2

- = A 1/4" oversize rod, standard in the 8" bore size, can be furnished using standard head castings. Rod end extension and related dimensions will therefore vary accordingly. See Table 2. Dimensions shown in this catalog may be altered without notice.
- = Dimension "I" will be furnished as shown unless otherwise specified. When ordering, please specify "I" dimension.

BORE	ROD DIA.	NO. 1 THREAD	NO. 3 THREAD	NO. 5 THREAD (FEMALE)	A	C	D	E	F	G	H	I ■	J	K	L	M	N	O
1-1/2	5/8	5/8-18	3/8-24	1/2-20	6-1/8	1-1/8	5/8	2-3/4	5/8	4	1/4	3-3/4	5/8	7/8	(4) 5/16	1-3/8	2-3/16	1/2
2	5/8	5/8-18	1/2-20	1/2-20	6-1/2	1-1/8	5/8	3	3/4	4-5/8	1/4	3-3/4	5/8	7/8	(4) 5/16	1-3/8	2-3/8	1/2
2-1/2	3/4	3/4-16	1/2-20	1/2-20	7-7/8	1-3/8	3/4	3-1/2	1	5-3/4	3/8	4-3/4	5/8	1-1/8	(4) 3/8	1-3/4	2-7/8	5/8
3	3/4	3/4-16	5/8-18	1/2-20	8-1/8	1-3/8	3/4	3-7/8	1-1/8	6-1/2	3/8	4-3/4	3/4	1-1/8	(4) 3/8	1-3/4	3-1/16	5/8
4	1	1-14	3/4-16	5/8-18	9-3/4	1-3/4	1	4-7/8	1-1/4	7-3/4	1/2	5-7/8	1	1-1/2	(4) 1/2	2	3-1/2	3/4
5	1	1-14	3/4-16	5/8-18	9-7/8	1-3/4	1	6-7/8	1-1/4	9	1/2	5-7/8	1	1-1/2	(6) 1/2	2	4-1/4	3/4
6	1-1/4	1-1/4-12	1-14	3/4-16	11-1/2	2-1/8	1	8-3/8	1-1/4	11	3/4	6-1/2	1	1-7/8	(6) 1/2	2-5/8	4-7/8	3/4
8	1-3/4	1-3/4-12	1-1/2-12	1-14	12-1/2	2-1/2	1-1/2	10-7/8	1-1/4	12-3/4	1	7-3/4	1-1/8	2-1/4	(6) 5/8	3-1/2	6-3/8	1
10	2	2-12	1-1/2-12	1-1/4-12	16	3-1/4	1-1/2	12-3/4	1-1/2	16-1/4	1-1/4	9-1/2	1-1/8	3	(8) 3/4	3-5/8	7-11/16	1-1/4
12	2-1/2	2-1/2-12	2-12	1-1/2-12	19-1/2	4	2	15-7/8	2	20-1/4	1-1/2	11-7/8	1-3/8	3-3/4	(8) 7/8	3-3/4	9-1/2	1-5/8
14	2-3/4	2-3/4-12	2-1/2-12	1-3/4-12	20-3/8	4	2-1/2	18-1/4	2-1/2	23-1/2	2	11-7/8	2	3-3/4	(8) 7/8	3-3/4	12-1/4	1-1/2

**Table 2** DIMENSION CHANGES FOR 1/4" OVERSIZE ROD DIAMETER & CLASS M

BORE	ROD DIA.	NO. 1 THREAD	NO. 3 THREAD	NO. 5 THREAD (FEMALE)	A NO. 1 THREAD	A NO. 3 & 5 THREAD	C NO. 1 THREAD	C NO. 3 & 5 THREAD	K NO. 1 THREAD	K NO. 3 THREAD	K NO. 5 THREAD (FEMALE)	I NO. 1 THREAD	I NO. 3 THREAD	I NO. 5 THREAD (FEMALE)
1-1/2	7/8	7/8-14	5/8-18	1/2-20	6-1/2	6-1/8	1-1/2	1-1/8	1-1/4	7/8	7/8	4-1/8	3-3/4	3-3/4
2	7/8	7/8-14	5/8-18	1/2-20	6-7/8	6-1/2	1-1/2	1-1/8	1-1/4	7/8	7/8	4-1/8	3-3/4	3-3/4
2-1/2	1	1-14	3/4-16	1/2-20	8-1/4	7-7/8	1-3/4	1-3/8	1-1/2	1-1/8	7/8	5-1/8	4-3/4	4-3/4
3	1	1-14	3/4-16	1/2-20	8-1/2	8-1/8	1-3/4	1-3/8	1-1/2	1-1/8	7/8	5-1/8	4-3/4	4-3/4
4	1-1/4	1-1/4-12	1-14	5/8-18	10-1/8	9-3/4	2-1/8	1-3/4	1-7/8	1-1/2	1-1/8	6-1/4	5-7/8	5-7/8
5	1-1/4	1-1/4-12	1-14	5/8-18	10-1/4	9-7/8	2-1/8	1-3/4	1-7/8	1-1/2	1-1/8	6-1/4	5-7/8	5-7/8
6	1-1/2	1-1/2-12	1-1/4-12	3/4-16	11-7/8	11-1/2	2-1/2	2-1/8	2-1/4	1-7/8	1-1/4	6-7/8	6-1/2	6-1/2
8	1-3/4	1-3/4-12	1-1/2-12	1-14	12-1/2	12-1/2	2-1/2	2-1/2	2-1/4	2-1/4	2-1/4	7-3/4	7-3/4	7-3/4
10	2-1/4	2-1/4-12	2-12	1-1/4-12	16-3/8	16	3-5/8	3-1/4	3-3/8	3	2	9-7/8	9-1/2	9-1/2
12	2-3/4	2-3/4-12	2-1/2-12	1-1/2-12	19-7/8	19-1/2	4-3/8	4	4-1/8	3-3/4	2-3/8	12-1/4	11-7/8	11-7/8
14	3	3-12	2-1/2-12	1-3/4-12	21-1/8	20-3/8	4-3/4	4	4-1/2	3-3/4	2-3/4	12-5/8	11-7/8	11-7/8

**CLASS M**



**CLASS M** Double Acting Cylinder

NOPAK Class M cylinders are strong and rugged in construction, especially designed for heavy duty applications in mines, quarries, steel mills, and in the heavy construction industries. Maximum system pressure is 650 PSI in all diameters to 4" – and 450 PSI in diameters of 5" and larger. The Class M construction is available in a full range of sizes and models (mountings) up through 14" in diameter for air, water or oil hydraulic service.

NO TIE RODS – Cylinder flanges are welded to steel cylinder tubing. High tensile alloy iron\* heads are bolted to those flanges.

Chrome plated or stainless steel piston rods and chrome plated or brass lined cylinder tubing can be furnished for water hydraulic applications.

\* Steel heads are available at extra cost.

**DIMENSIONS**

For mounting dimensions of Class M cylinders, use figures from tables of corresponding Class 1, shown on preceding pages, with exception of Piston Rod Diameter and Piston Rod Extension which are shown in tables below. Please note that dimension "I" varies from Class 1 or Class 2 dimension "I" as shown.

**Table 1** CLASS M PISTON ROD THREAD DIMENSIONS (Also Class 1 and 2 Standard Oversize)

See Clevis Information page 17

ROD END	CYLINDER DIAMETER										
	1-1/2	2	2-1/2	3	4	5	6	8	10	12	14
Thread	7/8-14	7/8-14	1-14	1-14	1-1/4-12	1-1/4-12	1-1/2-12	1-3/4-12	2-1/4-12	2-3/4-12	3-12
I Dim.-C	1-1/2	1-1/2	1-3/4	1-3/4	2-1/8	2-1/8	2-1/2	2-1/2	3-5/8	4-3/8	4-3/4
Dim.-K	1-1/4	1-1/4	1-1/2	1-1/2	1-7/8	1-7/8	2-1/4	2-1/4	3-3/8	4-1/8	4-1/2
Thread	1/2-20	1/2-20	1/2-20	1/2-20	5/8-18	5/8-18	3/4-16	1-14	1-1/4-12	1-1/2-12	1-3/4-12
3 Dim.-C	1-1/8	1-1/8	1-3/8	1-3/8	1-3/4	1-3/4	2-1/8	2-1/2	3-1/4	4	4
Dim.-K	7/8	7/8	7/8	7/8	1-1/8	1-1/8	1-1/4	2-1/4	2	2-3/8	2-3/4
Thread	5/8-18	5/8-18	3/4-16	3/4-16	1-14	1-14	1-1/4-12	1-1/2-12	2-12	2-1/2-12	2-1/2-12
5 Dim.-C	1-1/8	1-1/8	1-3/8	1-3/8	1-3/4	1-3/4	2-1/8	2-1/2	3-1/4	4	4
Dim.-K	7/8	7/8	1-1/8	1-1/8	1-1/2	1-1/2	1-7/8	2-1/4	3	3-1/4	3-3/4

**Table 2** MINIMUM I DIMENSIONS CLASS M MODEL F CYLINDERS

BORE	1-1/2	2	2-1/2	3	4	5	6	8	10	12	14
I Dimension	5	5	6	6	7-5/8	7-5/8	8-1/2	10-3/8	11-3/8	15-1/4	15-3/8

**CYLINDER FORCE AND AIR CONSUMPTION TABLE**

CYL. DIA.	ROD DIA.	THEORETICAL FORCE @ FLUID PRESSURE									CU. FT. FREE AIR* PER IN. PISTON TRAVEL AT 80 PSI
		40	60	80	100	125	200	250	450	650	
1-1/2	PUSH	70.8	106.0	141.4	176.7	220.9	353.4	441.8	795.2	1149	.00658
	PULL 5/8	58.4	87.6	116.8	146.0	182.6	292.1	365.1	657.1	949.2	.00658
	PULL 7/8	46.6	69.9	93.3	116.6	145.7	233.2	291.5	524.6	757.8	.00658
2	PUSH	125.7	188.5	251.3	314.2	392.7	628.3	785.4	1414	2042	.01175
	PULL 5/8	113.4	170.1	226.8	283.5	354.4	567.0	708.7	1276	1843	.01175
	PULL 7/8	101.6	152.4	203.2	254.0	317.5	508.1	635.1	1143	1651	.01175
2-1/2	PUSH	196.3	294.5	392.7	490.9	613.6	981.7	1227	2209	3191	.0183
	PULL 3/4	178.7	268.0	357.3	446.7	558.4	893.4	1117	2010	2903	.0183
	PULL 1	164.9	247.4	329.9	412.3	515.4	824.7	1031	1855	2680	.0183
3	PUSH	282.7	424.1	565.5	706.9	883.6	1414	1767	3181	4595	.0264
	PULL 3/4	265.1	397.7	530.1	662.7	828.4	1325	1657	2982	4307	.0264
	PULL 1	251.3	377.0	502.7	628.3	785.4	1257	1571	2827	4084	.0264
4	PUSH	502.7	754.0	1005	1257	1571	2513	3142	5655	8168	.0469
	PULL 1	471.2	706.9	942.5	1178	1473	2356	2945	5301	7658	.0469
	PULL 1-1/4	453.6	680.3	907.1	1134	1417	2268	2835	5103	7370	.0469
5	PUSH	785.4	1178	1571	1964	2454	3927	4909	8836	-	.0731
	PULL 1	754.0	1131	1508	1885	2356	3770	4712	8482	-	.0731
	PULL 1-1/4	736.3	1104	1473	1841	2301	3682	4602	8284	-	.0731
6	PUSH	1131	1696	2262	2827	3534	5655	7069	12723	-	.1055
	PULL 1-1/4	1082	1623	2164	2705	3381	5409	6762	12171	-	.1055
	PULL 1-1/2	1060	1590	2121	2651	3313	5301	6627	11928	-	.1055
8	PUSH	2011	3016	4021	5027	6283	10053	12566	22619	-	.188
	PULL 1-3/4	1914	2872	3829	4786	5982	9572	11965	21537	-	.188
10	PUSH	3142	4712	6283	7854	9818	15708	19635	35343	-	.294
	PULL 2	3016	4524	6032	7540	9425	15080	18850	33929	-	.294
	PULL 2-1/4	2983	4474	5965	7456	9320	14913	18641	33554	-	.294
12	PUSH	4524	6786	9048	11310	14138	22620	28275	50895	-	.423
	PULL 2-1/2	4328	6491	8655	10819	13524	21638	27048	48686	-	.423
	PULL 2-3/4	4286	6430	8573	10716	13395	21432	26790	48222	-	.423
14	PUSH	6158	9236	12315	15394	19243	30788	38485	69273	-	.575
	PULL 2-3/4	5920	8880	11840	14800	18500	29600	37000	66600	-	.575
	PULL 3	5875	8812	11750	14687	18359	29374	36718	66092	-	.575

\* = "Free Air" is normal atmospheric air (sea level) at compressor location. These figures are used in determining size of compressor required. Piston travel in double acting cylinders is twice the stroke. Free Air consumption at other line pressures will vary accordingly.

**TIE ROD (OR SOCKET HEAD CAP SCREWS ON CLASS M) TORQUE VALUES**

CYLINDER DIAMETER	TIE ROD		CLASS 1-2	CLASS M
	DIA. THD.	QTY.	TORQUE (FT. LB.)	TORQUE (FT. LB.)
1.50"	5/16-24 NF	4	7	14
2.00"	5/16-24 NF	4	7	14
2.50"	5/16-24 NF	4	7	14
3.00"	3/8-24 NF	4	14	20
4.00"	3/8-24 NF	4	14	20
5.00"	3/8-24 NF	6	14	20
6.00"	3/8-24 NF	6	14	20
8.00"	1/2-20 NF	6	40	70
10.00"	3/4-16 NF	8	100	200
12.00"	3/4-16 NF	8	100	200
14.00"	7/8-14 NF	8	170	300



## STANDARD MOUNTING BRACKET AND PIN

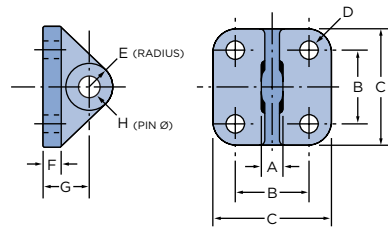

**Mounting Brackets** of high grade malleable iron or steel plate stock are designed to fit the blank end of Model E cylinders or into the slot of the clevises described below. Order by size and part number.

CYL. DIA.	A	B	C	D	E	F	G	BRACKET		MTG. PIN "H"	PIN	
								FORMER P/N	CURRENT P/N		FORMER P/N	CURRENT P/N
1-1/2	7/16	1-3/4	2-3/4	13/32	1/2	3/8	1-3/16	1430CY	1801L00	3/8	3253CY-1	3221L46-1
2	7/16	2	3-1/4	17/32	5/8	1/2	1-3/8	1630CY	1802L46	1/2	3253CY-3	3221L46-3
2-1/2	7/16	2	3-1/4	17/32	5/8	1/2	1-3/8	1630CY	1802L46	1/2	3253CY-3	3221L46-3
3	7/16	2	3-1/4	17/32	5/8	1/2	1-3/8	1630CY	1802L46	1/2	3253CY-3	3221L46-3
4	5/8	3-1/4	4-1/2	17/32	7/8	1/2	1-3/4	1796CY	1803L46	3/4	3253CY-4	3221L46-4
5	5/8	3-1/4	4-1/2	17/32	7/8	1/2	1-3/4	1796CY	1803L46	3/4	3253CY-4	3221L46-4
6	7/8	4-1/4	5-1/2	17/32	1-1/8	5/8	2	1797CY	1804L06	7/8	3253CY-5	3221L46-5
8	1	5	6-1/2	21/32	1-1/4	3/4	2-1/2	1798CY	1805L07	1	3253CY-6	3221L46-6
10	1-1/4	6	8	25/32	1-1/2	1	3	1799CY	1806L08	1-1/4	3253CY-7	3221L46-7
12	1-3/4	6-3/4	10	1-1/16	2	1-1/4	3-1/2	1800CY	1807L09	1-1/2	3253CY-8	3221L46-8
14	2-1/4	8	10-1/2	1-5/16	2-1/8	1-1/2	3-3/4	2958CY	1767L46	1-3/4	3253CY-9	3221L46-9

## STANDARD FEMALE CLEVIS AND PIN

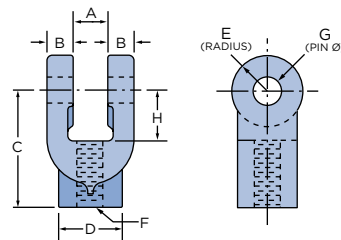

**Clevises** of high grade malleable iron are available for all standard model and size Class 1 and 2 cylinders. Clevises for any diameter cylinder are threaded for that particular standard 1 rod end. Class 1 and 2 cylinders with oversize rod and Class M cylinders will therefore require a larger clevis unless the rod end is turned down. Be sure to specify when ordering. Special clevises available made to order.

CYL. DIA.*	THREAD "F"■	A	B	C	D	E	G	H	CLEVIS		MTG. PIN "G"	PIN	
									FORMER P/N	CURRENT P/N		FORMER P/N	CURRENT P/N
1-1/2	5/8-18	17/32	3/8	1-5/8	1	1/2	1/2	3/4	4330CY	1787L46	1/2	3253CY-3	3221L46-3
2	5/8-18	17/32	3/8	1-5/8	1	1/2	1/2	3/4	4330CY	1787L46	1/2	3253CY-3	3221L46-3
2-1/2	3/4-16	17/32	1/2	2	1-1/4	5/8	1/2	7/8	4331CY	1788L46	1/2	3253CY-3	3221L46-3
3	3/4-16	17/32	1/2	2	1-1/4	5/8	1/2	7/8	4331CY	1788L46	1/2	3253CY-3	3221L46-3
4	1-14	25/32	3/4	2-5/8	1-1/2	3/4	3/4	1-1/8	4332CY	1789L46	3/4	3253CY-4	3221L46-4
5	1-14	25/32	3/4	2-5/8	1-1/2	3/4	3/4	1-1/8	4332CY	1789L46	3/4	3253CY-4	3221L46-4
6	1-1/4-12	1-1/32	15/16	3-1/4	1-3/4	1-1/8	7/8	1-3/8	4333CY	1790L06	7/8	3253CY-5	3221L46-5
8	1-3/4-12	1-9/32	1	3-3/4	2-1/2	1-1/4	1	1-1/2	16989CY	1791L07	1	3253CY-6	3221L46-6
10	2-12	1-17/32	1-1/4	4-3/4	3	1-1/2	1-1/4	1-3/4	1373CY	1792L08	1-1/4	3253CY-7	3221L46-7
12	2-1/2-12	2-1/32	1-1/2	5-7/8	3-1/2	1-3/4	1-1/2	2-1/8	1374CY	1793L46	1-1/2	3253CY-8	3221L46-8
14▲	2-1/2-12	2-1/32	1-1/2	5-7/8	3-1/2	1-3/4	1-1/2	2-1/8	1374CY	1793L46	1-1/2	3253CY-8	3221L46-8

- \* = Indicates Class 1 and 2 cylinder diameter with Standard 1 NF rod end which clevis will fit.
- = 1-1/2-12 thread clevis 7286L07 (4334CY) available. Dimensions on 1791L07 (18510CY) apply.
- ▲ = For 5 Rod only on 14" diameter.

## STANDARD ROD EYE AND PIN

THREAD	A	CA	CB	CD	ER	ROD EYE		PIN	
						FORMER P/N	CURRENT P/N	FORMER P/N	CURRENT P/N
5/8-18	7/8	1-5/8	1	1/2	3/4	21789CY	1811L59	3253CY-3	3221L46-3
3/4-16	1-1/8	2-1/16	1-1/4	3/4	1-1/16	7061CY	1812L59	3253CY-4	3221L46-4
1-14	1-5/8	2-13/16	1-1/2	1	1-7/16	7062CY	1813L59	3253CY-6	3221L46-6
1-1/4-12	2	3-7/16	2	1-3/8	2	7063CY	1814L59	3253CY-4	3221L46-4
1-3/4-12	2-1/4	4	2-1/2	1-3/4	2-1/16	21790CY	1816L59	3253CY-9	3221L46-9
2-12	3	5	2-1/2	2	2-1/4	23464CY	1819L59	3253CY-11	3221L46-11
2-1/2-12	3-1/2	6-1/8	3	3	3-1/4	23465CY	1823L59	3253CY-7	3221L46-7

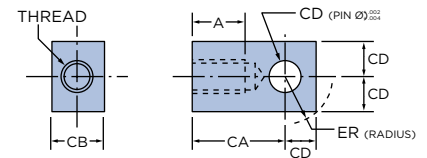

**Rod eyes** of mild steel are available for all standard model and size Class 1 and Class 2 cylinders with 1 rod ends. Other sizes of rod eyes are also available. Pins for rod eye, are not furnished unless requested.

## TYPICAL PIN STYLES

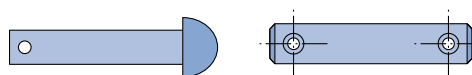

**REPLACEMENT PARTS**

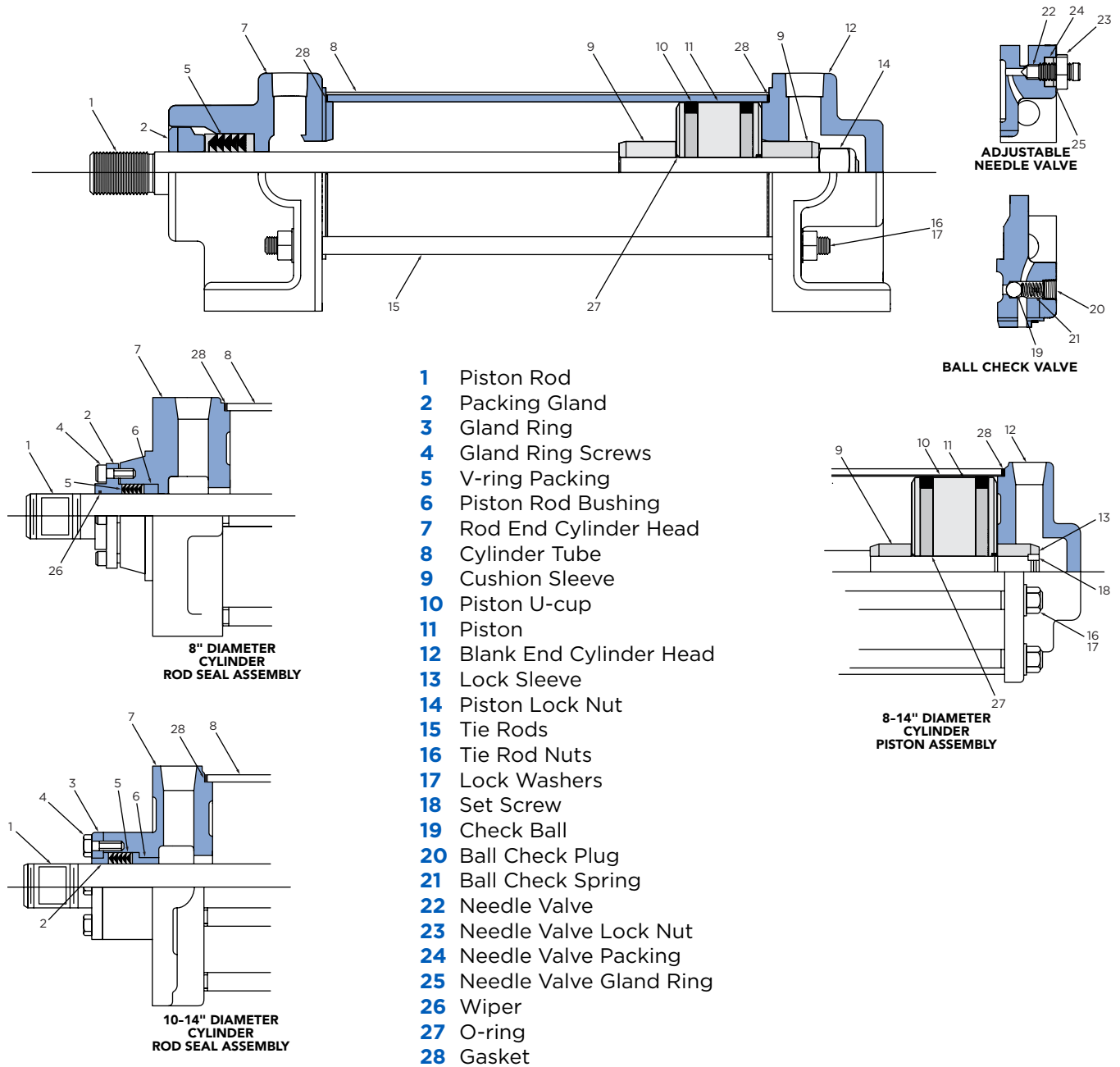

- 1** Piston Rod
- 2** Packing Gland
- 3** Gland Ring
- 4** Gland Ring Screws
- 5** V-ring Packing
- 6** Piston Rod Bushing
- 7** Rod End Cylinder Head
- 8** Cylinder Tube
- 9** Cushion Sleeve
- 10** Piston U-cup
- 11** Piston
- 12** Blank End Cylinder Head
- 13** Lock Sleeve
- 14** Piston Lock Nut
- 15** Tie Rods
- 16** Tie Rod Nuts
- 17** Lock Washers
- 18** Set Screw
- 19** Check Ball
- 20** Ball Check Plug
- 21** Ball Check Spring
- 22** Needle Valve
- 23** Needle Valve Lock Nut
- 24** Needle Valve Packing
- 25** Needle Valve Gland Ring
- 26** Wiper
- 27** O-ring
- 28** Gasket

**HOW TO ORDER**

**When using this parts list for replacements, be sure to identify:**

- 1. Part by name and item number.
- 2. Diameter of cylinder.
- 3. Model of cylinder.
- 4. Serial number on NOPAK cylinder label.

# REED PROXIMITY SWITCH

## AIR CYLINDER APPLICATIONS



cause the reeds to flex and contact each other. When the magnetic field is removed, they will again spring apart to their normal positions.

The cylinder/Reed Switch combination operates by using a magnetic band on the cylinder piston, which closes the externally mounted reed switch, as it approaches. When the piston moves away again the switch opens.

Proper application of this versatile Reed Switch can offer millions of cycles of trouble-free operation.

## LONG LIFE/HIGH PERFORMANCE

### FEATURES AND ADVANTAGES

- Adjustable mounting allows switches to be located anywhere within range of piston travel.
- Several switches may be mounted to control or initiate any sequence function.
- No externally moving parts to wear or maintain.
- Suited for use in plant environments where dirt and contamination create difficulties for electromechanical and other types of controls.
- Neon Indicator Light provides convenient means for positioning and troubleshooting switch and circuits.
- Suitable for AC service only.

### WORKING PRINCIPLE

Basically the Reed Switch consists of two overlapping ferro magnetic blades (reeds). The reeds are hermetically sealed inside a glass tube leaving a small air gap between them.

Since the reeds are magnetic, they will assume opposite polarity and be attracted to each other when influenced by a magnetic field. Sufficient magnetic flux density will

### 3 AMP REED SWITCH SPECIFICATIONS

Circuit - Normally open - SPST (Form A)

VA (Max) - 360

Switching voltage - 65-120 VAC (50/60 Hz)

Current (Break) - 3.0 Amp

Leakage - 1.7 mA

Response Time - 15 ms On, 0.83 ms Off

Switch Burden Current - 5 mA

**Note:** All incandescent loads derate switch capacity to 10% due to inrush current.

Moisture and dust proof (no NEMA rating)

### SHOCK RATING

The basic switch can withstand up to 60 G maximum in the direction of contact closure without misfire or malfunction.

### VIBRATION SENSITIVITY

Switch will withstand amplitude of 30 G at frequencies up to 6000 Hz without misfire. False operation can occur at vibration frequency levels higher than 6000 Hz.

### OPERATING TEMPERATURE

-40°F to +170°F for standard cable.

### CABLE SPECIFICATION

The conductors are tinned copper with polyethylene insulation, conductors are cabled with a rayon braid, a tinned copper braided shield and a chrome vinyl jacket that is resistant to hydraulic fluids.

### SWITCH WIRING SCHEMATIC

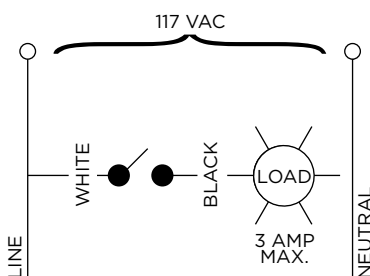

### CAUTION

**Do not connect switch without a load. Permanent damage to switch will result.**

**NOTE:** Switch is internally protected against failure due to normal electrical transient levels. However, it may be necessary to use additional transient protection if high levels exist.

### ORDER NUMBERS

For switch and bracket assembly complete or separate units.

**10990E00** For switch and bracket assembly

**10988E00** Part No. - Switch Unit

**3985E00** Part No. - Adjustable Bracket Unit



# Class 1 SVR

Severe Service Hydraulic and Pneumatic Cylinders

---



**TABLE OF CONTENTS**

Severe Service Cylinders . . . . . 22  
 Replacement Parts . . . . . 24  
 How To Order . . . . . 24

- Piston rod packing box is designed for double bearings and oversize rods with bolt-on steel plate packing retainers.
- Easily adjustable rod seals are a multiple stack split V-packing available in fabric-reinforced nitrile or fabric-reinforced Fluorocarbon.
- Piston rod has larger diameter (beyond the oversize Class 1, 2 or M).
- Piston rod thread lengths are longer than standard Class 1, 2, or M to incorporate a hex jam nut (employed to adjust and lock clevis or rod eye accessories).

**NOTE:** Applies to Models C, E, F, & H mountings only. For double rod bearing features in 10, 12, and 14 inch bores, refer to Class 1, 2, M Section.

**MODEL C**

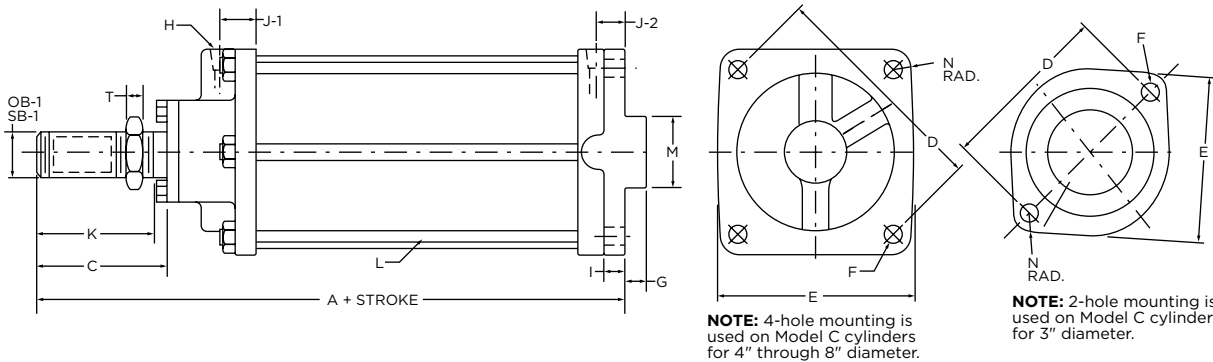

**MODEL E**

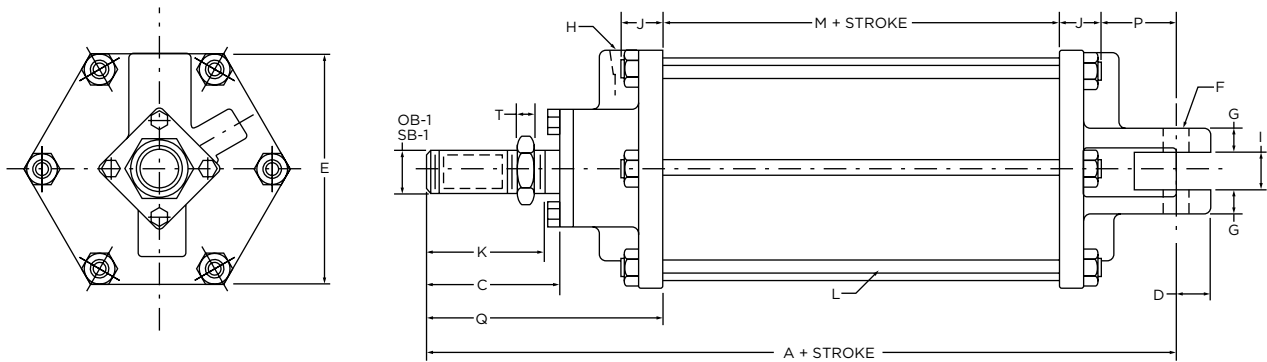

**MODEL F**

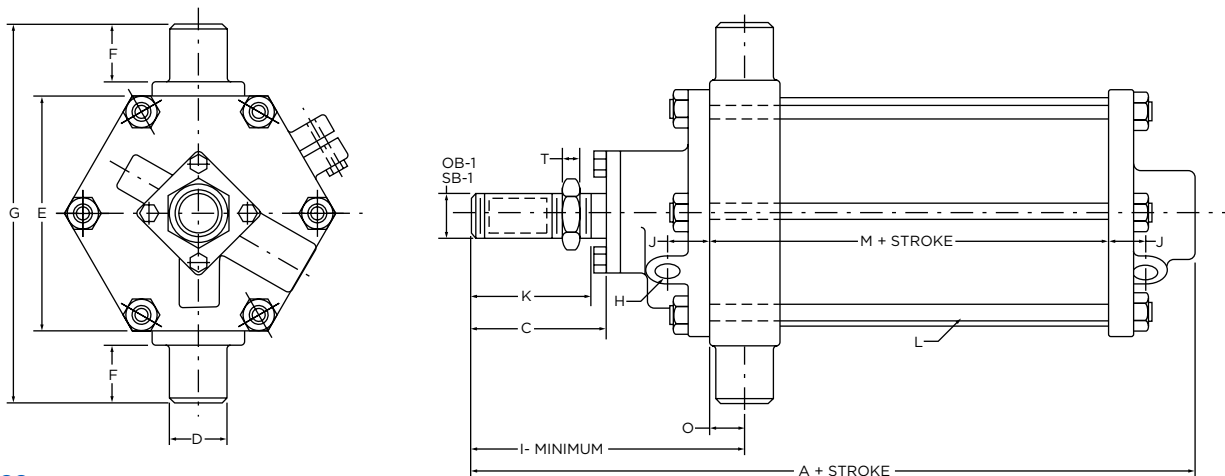

# SEVERE SERVICE CYLINDERS

## MODEL H

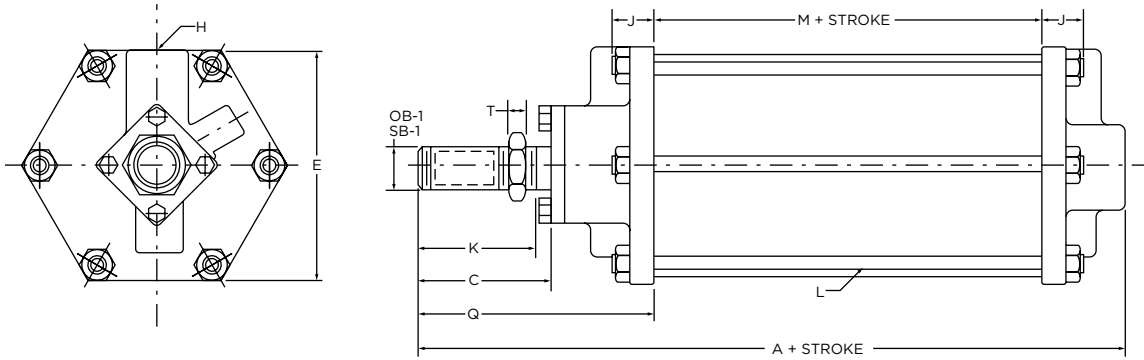

**Table 1** BASIC DIMENSIONS MODEL C

BORE	ROD DIA.	NO. 1 THREAD	A	C	D	E	F	G	H	I	J-1	J-2	K	L	M	N	T
3.00	1.00	1.00-14	8.625	2.375	5.250	4.875	.531	.750	.375	.625	.750	.750	2.125	(4) .375	2.125	.625	.500
	1.25	1.25-12	9.125	2.875									2.625				
4.00	1.25	1.25-12	10.000	2.875	7.750	6.750	.531	.875	.500	.625	1.000	.750	2.625	(4) .500	2.625	.625	.688
	1.50	1.50-12	10.625	3.500									3.250				
5.00	1.25	1.25-12	10.125	2.875	7.750	7.250	.531	.875	.500	.750	1.000	.875	2.625	(6) .500	2.625	.625	.688
	1.50	1.50-12	10.750	3.500									3.250				
6.00	1.50	1.50-12	11.688	3.500	9.000	8.375	.531	1.125	.750	.750	1.000	.875	3.250	(6) .500	3.000	.625	.875
	1.75	1.75-12	11.813	3.625									3.375				
8.00	2.00	2.00-12	15.125	4.500	10.750	10.875	.781	-	1.000	.875	1.125	1.250	4.250	(6) .625	-	.875	1.063
	2.25	2.25-12	15.250	4.625									4.375				

**Table 2** BASIC DIMENSIONS MODEL E

BORE	ROD DIA.	NO. 1 THREAD	A	C	D	E	F	G	H	I	J	K	L	M	P	Q	T
3.00	1.00	1.00-14	10.187	2.375	.625	3.750	.500	.500	.375	.500	.750	2.125	(4) .375	1.750	2.312	5.375	.500
	1.25	1.25-12	10.688	2.875								2.625					
4.00	1.25	1.25-12	11.875	2.875	.875	4.875	.750	.750	.500	.750	1.000	2.625	(4) .500	2.000	2.625	6.250	.688
	1.50	1.50-12	12.500	3.500								3.250					
5.00	1.25	1.25-12	12.000	2.875	.875	6.375	.750	.750	.500	.750	1.000	2.625	(6) .500	2.000	2.750	6.250	.688
	1.50	1.50-12	12.625	3.500								3.250					
6.00	1.50	1.50-12	14.063	3.500	1.125	7.250	.875	1.000	.750	1.000	1.000	3.250	(6) .500	2.625	3.375	7.063	.875
	1.75	1.75-12	14.187	3.625								3.375					
8.00	2.00	2.00-12	16.500	4.500	1.250	9.625	1.000	1.000	1.000	1.000	1.125	4.250	(6) .625	3.500	2.625	9.250	1.063
	2.25	2.25-12	16.625	4.625								4.375					

**Table 3** BASIC DIMENSIONS MODELS F & H

BORE	ROD DIA.	NO. 1 THREAD	A	C	D	E	F	G	H	I	J	K	L	M	N	O	T
3.00	1.00	1.00-14	9.375	2.375	.750	3.875	1.125	6.500	.375	6.000	.750	2.125	(4) .375	1.750	3.063	.625	.500
	1.25	1.25-12	9.875	2.875								6.500					
4.00	1.25	1.25-12	10.875	2.875	1.000	4.875	1.250	7.750	.500	7.000	1.000	2.625	(4) .500	2.000	3.500	.750	.688
	1.50	1.50-12	11.500	3.500								7.625					
5.00	1.25	1.25-12	11.000	2.875	1.000	6.875	1.250	9.000	.500	7.000	1.000	2.625	(6) .500	2.000	4.250	.750	.688
	1.50	1.50-12	11.625	3.500								7.625					
6.00	1.50	1.50-12	12.812	3.500	1.000	8.375	1.250	11.000	.750	7.813	1.000	3.250	(6) .500	2.625	4.875	.750	.875
	1.75	1.75-12	12.938	3.625								7.938					
8.00	2.00	2.00-12	15.000	4.500	1.500	10.875	1.250	12.750	1.000	10.250	1.125	4.250	(6) .625	3.500	6.375	1.000	1.063
	2.25	2.25-12	15.125	4.625								10.375					

**REPLACEMENT PARTS**

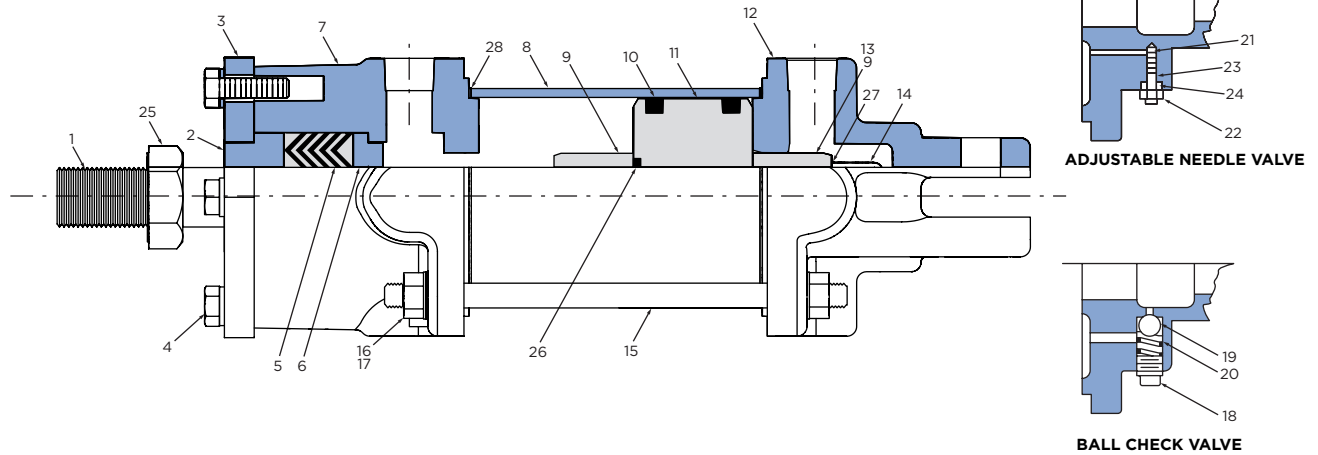

- |                                |                                      |                                    |
|--------------------------------|--------------------------------------|------------------------------------|
| <b>1</b> Piston Rod            | <b>12</b> Blank End Cylinder Head    | <b>22</b> Needle Valve Lock Nut    |
| <b>2</b> Packing Gland         | <b>13</b> Lock Sleeve (8" Diameter)* | <b>23</b> Needle Valve Packing     |
| <b>3</b> Gland Ring            | <b>14</b> Piston Lock Nut            | <b>24</b> Needle Valve Gland Ring  |
| <b>4</b> Gland Ring Screws     | <b>15</b> Tie Rods                   | <b>25</b> Hex Jam Nut              |
| <b>5</b> V-ring Packing        | <b>16</b> Tie Rod Nuts               | <b>26</b> O-ring                   |
| <b>6</b> Piston Rod Bushing    | <b>17</b> Lock Washers               | <b>27</b> Set-Screw (8" Diameter)* |
| <b>7</b> Rod End Cylinder Head | <b>18</b> Ball Check Plug            | <b>28</b> Gasket                   |
| <b>8</b> Cylinder Tube         | <b>19</b> Ball Check Ball            |                                    |
| <b>9</b> Cushion Sleeve        | <b>20</b> Ball Check Spring          |                                    |
| <b>10</b> Piston Cups          | <b>21</b> Needle Valve               |                                    |
| <b>11</b> Piston               |                                      |                                    |

\* To Be Replaced in Pairs

**HOW TO ORDER**

**When using this parts list for replacements, be sure to identify:**

1. Part by name and item number.
2. Diameter of cylinder.
3. Model of cylinder.
4. Serial number on NOPAK cylinder label.

**ORDERING CODE EXAMPLE**

**1 - CL1/SVR - 4 x 16 - E - S A - 1.00 - 1**

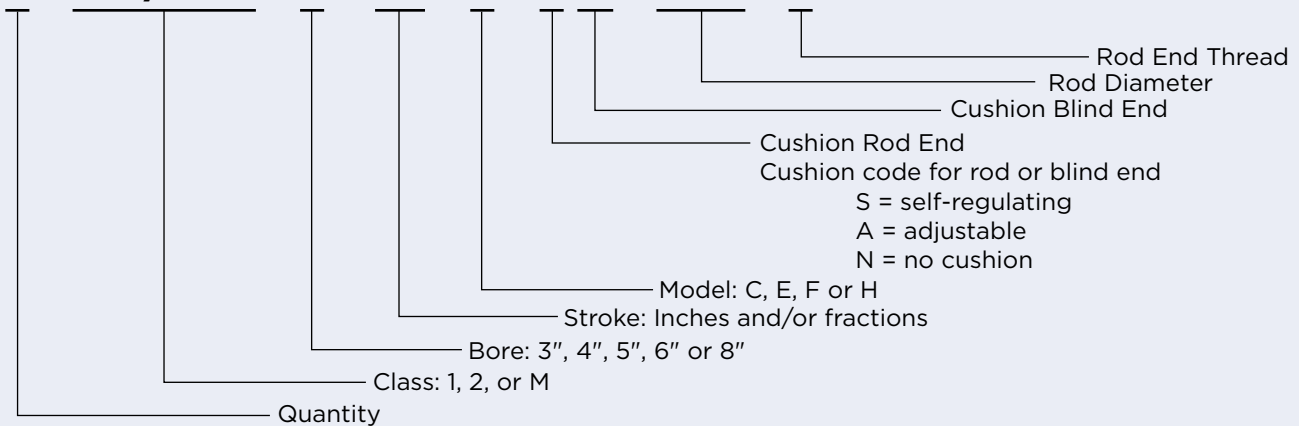



# Class 3

High Pressure Square-Head Cylinders

---



## TABLE OF CONTENTS

Pressure Ratings (PSI) .....	26
Approximate Class 3 Hydraulic Cylinder Weights (lbs) .....	26
Mounting Styles Index .....	27
Standard Features .....	28
Options, Modifications and Ordering Information .....	29
Flange Mount Cylinders	
1-1/2" Through 8" Bore .....	30
Flange and Square-Head Mount Cylinders	
10" Through 20" Bore .....	32
Rod Head and Blind Head Rectangular Mount Cylinders	
1-1/2" Through 12" Diameter .....	34
Side and Lug Mount Cylinders	
1-1/2" Through 7" Diameter .....	36
8" Through 20" Diameter .....	38
End Lug and Clevis Mount Cylinders	
1-1/2" Through 7" Diameter .....	40
8" Through 20" Diameter .....	42
Fixed Eye Mount Cylinders	
1-1/2" Through 20" Diameter .....	44
Spherical Eye Mount Cylinders	
1-1/2" Through 6" Diameter .....	46
Trunnion Mount Cylinders	
1-1/2" Through 7" Diameter .....	48
8" Through 14" Diameter .....	50
Tie-Rod Mount Cylinders	
1-1/2" Through 8" Diameter .....	52
10" Through 14" Diameter .....	54
Basic Model No Mount and Double Rod End Cylinders	
1-1/2" Through 6" Diameter .....	56
7" Through 20" Diameter .....	58
Piston Rod Ends .....	60
Cylinder Accessories .....	61
Proximity Position Indicator Switch .....	62
NOPAK Linear Displacement Transducer System .....	63
How To Order .....	63
Engineering Information .....	64
Engineering Data .....	66
Replacement Parts .....	68
Exploded View .....	68
Repair Kits - Class 3 .....	69
Packing Glands - Class 3 .....	69

## PRESSURE RATINGS (PSI)

CYL. BORE	4/1*	RECOMMENDED MAXIMUM CONTINUOUS PRESSURE
1-1/2	2265	3000
2	3209	3000
2-1/2	3209	3000
3-1/4	2465	3000
4	2288	3000
5	2752	3000
6	2326	3000
7	2632	3000
8	2326	3000
10	3072	3000
12	2710	3000
14	2631	3000
16	2014	3000
18	2099	3000
20	2064	3000

- \* = The 4/1 pressure rating is the lowest calculated value of the various pressure containing elements of a cylinder and is based on 1/4th of the minimum tensile strength of the material. While this is a conservative rating method, it does not include factors for type of mounting, length of stroke, method or speed of load application, fluid, temperature, environment, or fatigue. For specific recommendations consult your nearest NOPAK field representative or factory application engineer.

## APPROXIMATE UNCRATED CLASS 3 HYDRAULIC CYLINDER WEIGHTS (LBS)

CYLINDER BORE	1-1/2	2	2-1/2	3-1/4	4	5	6	7	8	10	12	14	16	18	20
BASIC MODELS ZERO STROKE	7.8	12	17.5	33	45	81	137	193	298	532	890	1480	1930	2810	3700
MODELS ME, MF, MP & MT - ADD:	2.2	3	3.5	7	8	13	20	27	36	84	130	270	420	540	800
STANDARD ROD PER INCH OF STROKE	.45	.75	1.1	1.6	2.5	4.0	5.2	6.3	8.2	15.5	23	32	38	48	57
LARGE ROD PER INCH OF STROKE	.59	.95	1.6	2.1	3.2	5.8	7.4	9.9	12.2	21.9	30	43	46	52	-

# MOUNTING STYLES INDEX

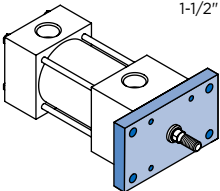
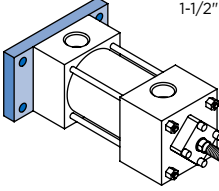
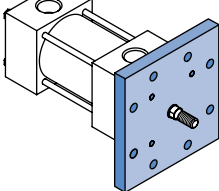
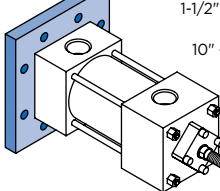
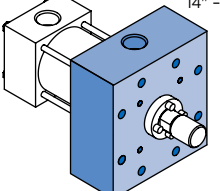
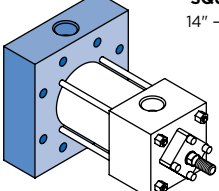
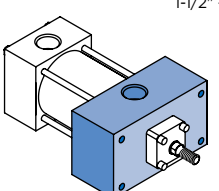
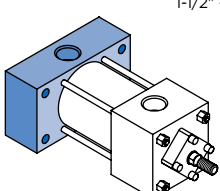
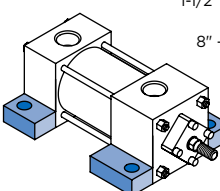
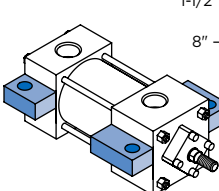
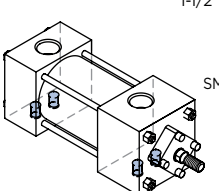
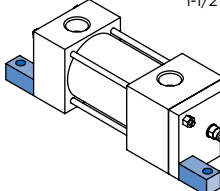
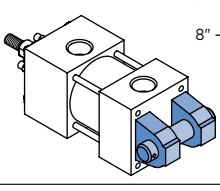
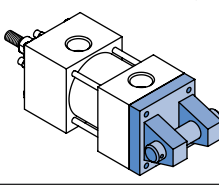
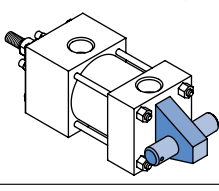
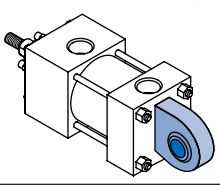
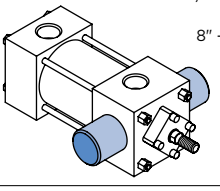
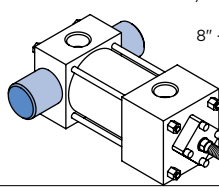
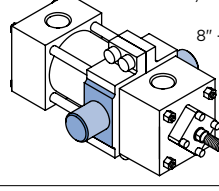
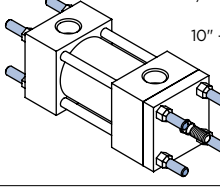
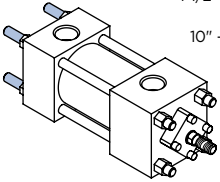
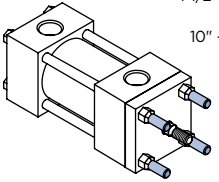
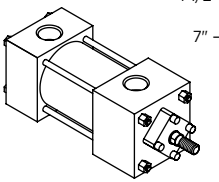
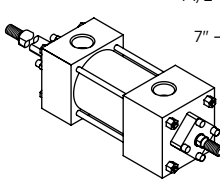
<p><b>MODEL D</b> (NFPA STD. MF1) 1-1/2" - 8" DIA. BORE PAGE 30</p> 	<p><b>MODEL C</b> (NFPA STD. MF2) 1-1/2" - 8" DIA. BORE PAGE 30</p> 	<p><b>MODEL DD</b> (NFPA STD. MF5) 1-1/2" - 8" DIA. BORE PAGE 30 10" - 12" DIA. BORE PAGE 32</p> 	<p><b>MODEL CC</b> (NFPA STD. MF6) 1-1/2" - 8" DIA. BORE PAGE 30 10" - 12" DIA. BORE PAGE 32</p> 
<p><b>MODEL DG</b> (ROD HEAD SQUARE MOUNT) 14" - 20" DIA. BORE PAGE 32</p> 	<p><b>MODEL CJ</b> (BLIND HEAD SQUARE MOUNT) 14" - 20" DIA. BORE PAGE 32</p> 	<p><b>MODEL G</b> (NFPA STD. ME5) 1-1/2" - 12" DIA. BORE PAGE 34</p> 	<p><b>MODEL J</b> (NFPA STD. ME6) 1-1/2" - 12" DIA. BORE PAGE 34</p> 
<p><b>MODEL A</b> (NFPA STD. MS2) 1-1/2" - 7" DIA. BORE PAGE 36 8" - 14" DIA. BORE PAGE 38</p> 	<p><b>MODEL B</b> (NFPA STD. MS3) 1-1/2" - 7" DIA. BORE PAGE 36 8" - 20" DIA. BORE PAGE 38</p> 	<p><b>MODEL S</b> (NFPA STD. MS4) 1-1/2" - 7" DIA. BORE PAGE 36 8" DIA. BORE PAGE 38 SMALL ROD ONLY</p> 	<p><b>MODEL AL</b> (NFPA STD. MS7) 1-1/2" - 7" DIA. BORE PAGE 40 8" DIA. BORE PAGE 42</p> 
<p><b>MODEL E</b> (NFPA STD. MP1) 1-1/2" - 7" DIA. BORE PAGE 40 8" - 20" DIA. BORE PAGE 42</p> 	<p><b>MODEL HE</b> (NFPA STD. MP2) 1-1/2" - 7" DIA. BORE PAGE 40 8" DIA. BORE PAGE 42</p> 	<p><b>MODEL E3</b> (NFPA STD. MP3) 1-1/2" - 20" DIA. BORE PAGE 44</p> 	<p><b>MODEL EU3</b> (NFPA STD. MPU3) 1-1/2" - 6" DIA. BORE PAGE 46</p> 
<p><b>MODEL FR</b> (NFPA STD. MT1) 1-1/2" - 7" DIA. BORE PAGE 48 8" - 14" DIA. BORE PAGE 50</p> 	<p><b>MODEL FB</b> (NFPA STD. MT2) 1-1/2" - 7" DIA. BORE PAGE 48 8" - 14" DIA. BORE PAGE 50</p> 	<p><b>MODEL F</b> (NFPA STD. MT4) 1-1/2" - 7" DIA. BORE PAGE 48 8" - 14" DIA. BORE PAGE 50</p> 	<p><b>MODEL T</b> (NFPA STD. MX1) 1-1/2" - 8" DIA. BORE PAGE 52 10" - 14" DIA. BORE PAGE 54</p> 
<p><b>MODEL TB</b> (NFPA STD. MX2) 1-1/2" - 8" DIA. BORE PAGE 52 10" - 14" DIA. BORE PAGE 54</p> 	<p><b>MODEL TR</b> (NFPA STD. MX3) 1-1/2" - 8" DIA. BORE PAGE 52 10" - 14" DIA. BORE PAGE 54</p> 	<p><b>MODEL H</b> (BASIC CYLINDER NO MOUNT) 1-1/2" - 6" DIA. BORE PAGE 56 7" - 20" DIA. BORE PAGE 58</p> 	<p><b>MODEL XH</b> (BASIC CYLINDER DOUBLE ROD END) 1-1/2" - 6" DIA. BORE PAGE 56 7" - 20" DIA. BORE PAGE 58 AVAILABLE IN MOST MODELS</p> 

**HIGH PRESSURE SQUARE-HEAD  
CLASS 3 HYDRAULIC CYLINDERS CUTAWAY VIEW**

**PISTON -**

High strength, fine grain cast iron piston fitted with split "Tongue-seal" cast iron piston rings on either side of a homogenous "T" ring furnished with backup rings. "T" ring furnished on all models and bores 1-1/2" through 16" diameter; 18" and 20" fitted with piston rings. Other designs on application. The outboard piston rings effectively seal off initial shock loads and allow the "T" ring to seal any bypass fluid to provide a leak-proof piston seal with maximum life.

**HEAVY WALL -**

Steel tubing, precision honed with extra long stones to provide overlap and eliminate a spiral condition detrimental to long stroke cylinders. The resulting ultra-smooth finish provides maximum seal life.

**TUBE SEAL -**

Two-step pilot recess grooves afford positive controlled squeeze on pressure sealed O-ring, while tubing locates concentrically against end cap.

**TIE ROD -**

Material is stressproof steel for maximum strength. Multiple tie rods in each corner are furnished on all models, 10" through 20" diameter bores.

**ROD PACKING -**

Choice of self-adjusting to pressure, multi-lip split seal or continuous pre-loaded lip seal.

**PACKING GLAND -**

Readily removable long bearing type, held in place with socket head cap screws. Rod packing easily replaced without loosening tie rods or dismantling cylinder.

**ROD WIPER -**

Wipes rod clean and dry. Keeps foreign matter from entering cylinder, extending packing life.

**CUSHION BALL CHECK -**

Assures quick starting under full power; pressure acts on full piston area instantaneously.

**CUSHION SLEEVES -**

Precision fitted with predetermined taper to provide gradual deceleration and reduce shock.

**PISTON ROD -**

High tensile 100,000 PSI minimum yield stressproof steel, ground, polished, and flash chrome plated .0003/.0005 to provide a hard, long-wearing surface with low friction, but not corrosion resistant. Consult factory for special applications.

**CUSHION ADJUSTMENT NEEDLE -**

Needle valves and ball check drilling and machining are identical, making location of these functions interchangeable.

**END CAPS -**

(Cylinder Heads)  
Precision broached steel blocks.

**ROD END THREADING -**

Choice of standard catalog male and female thread types plus standard wrench flats.



**ALTERNATE  
FLUSH  
CUSHION  
DESIGN**

## OPTIONS

### BORE SIZE SELECTION

Unlike air applications, the output force of a cylinder for hydraulic service need be only slightly greater than the required force. Hydraulic cylinder speed is dependent directly on the relationship of supply flow rate to cylinder volume. Force tables to aid in cylinder sizing are on page 65.

### MOUNTINGS

Select the cylinder mounting which will keep the line of force as close as possible to the centerline of the piston rod and free of misalignment. This will maximize seal and bearing life.

## CUSTOM MODIFICATIONS

### STOP TUBES

In long cylinders used on push applications, internal stop tubes are installed to prevent excessive bearing wear. They are located between the piston and rod end head. See page 66 for instructions.

### OVERSIZE RODS

For long, push stroke cylinders, oversize rods may be required. See page 66 for instructions.

### DOUBLE ROD END

NOPAK Class 3 cylinders when ordered as double rod end are designated by prefixing the model with the letter "X." Mounting dimensions may vary from standard because two rod end heads are used. See page 56 through page 59.

### CUSHIONS

NOPAK Class 3 cylinders are available with adjustable cushions on either or both ends, or non-cushion. The purpose of a cushion is to slow up piston speed at the end of the stroke, eliminating shock. The mass to be cushioned should be limited to one-half the cylinder force unless other provisions are made for deceleration or special cushioning.

### PISTON ROD EXTENSION AND ROD THREADING

Longer than standard piston rod extensions may be required to accommodate load fastening. Depending upon the details of rod engagement to load, special threading or rod end configuration may be required.

### CYLINDER PORTS

Ports are offered as NPTF, SAE O-ring or SAE Flange Type. NPTF ports standard for 1-1/2" thru 8" diameter cylinder bores. To increase cylinder speed, increased fluid volume is necessary. This can be done by using enlarged or additional ports.

## HOW TO ORDER

**You can help ensure prompt processing of your order by including all of the following requested information:**

1. Quantity required.
2. Specify Class 3.
3. Bore or cylinder diameter size.
4. Stroke length in inches.
5. Type of mounting (NOPAK model or NFPA style.)
6. Type of cushioning:  
 NN = non-cushioned  
 NA = cushioned blind end  
 AN = cushioned rod end  
 AA = cushioned both ends
7. Piston rod diameter and type of rod threading - specify Type 1, 3, 4, 5, 6 or 7. See page 60.

### Also Specify:

1. Position of cylinder ports and cushion adjustment screw, if other than standard. Standard positions are:  
 Cylinder ports - position 1  
 Ball check - position 2  
 Cushion adjustment - position 4
2. Extreme high or low operating or ambient temperatures.
3. Extreme operating pressures.
4. Type of operating fluid if other than standard petroleum base oil.
5. Any unusual operating conditions.

## ORDERING CODE EXAMPLE

**CL3 - 4 x 18 - A - Δ Δ - 1.75 - 4 - OPT**

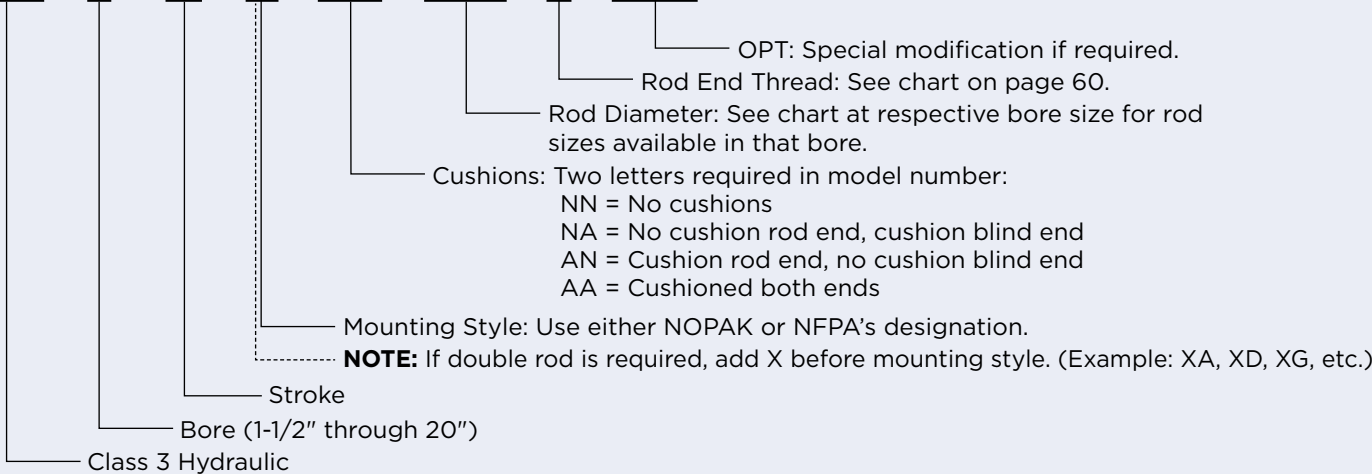

**MODEL C (NFPA STD. MF2) ▲**

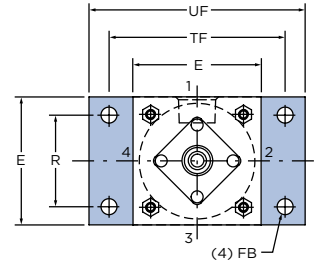
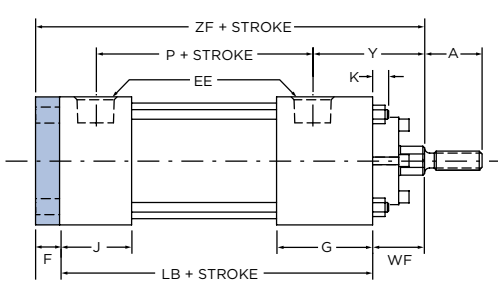
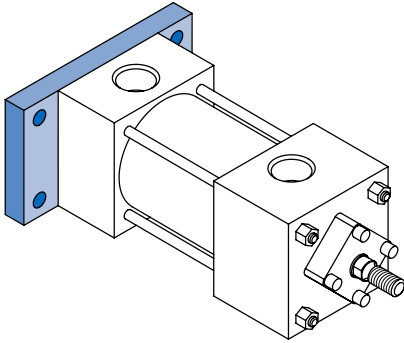

**PRESSURE LIMITATIONS (PULL)**

CYL. DIAMETER	5	6	7	8
PRESSURE (PSI)	2000	1600	1200	1000

Use Model CC (below) or Model J (page 34) for Recommended Maximum Pressure.

**MODEL CC (NFPA STD. MF6)**

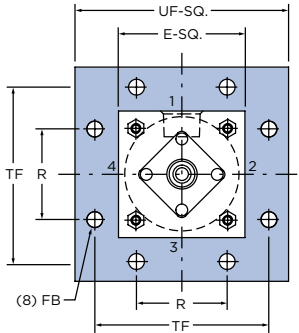
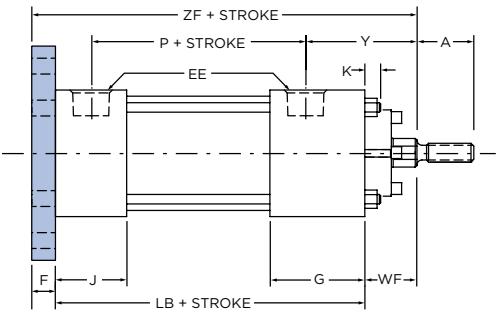
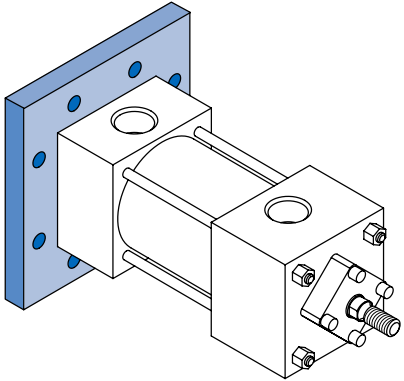

**MODEL D (NFPA STD. MF1)**

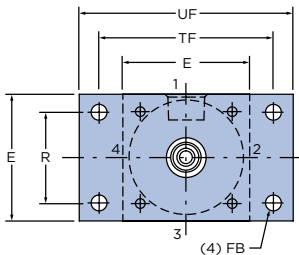
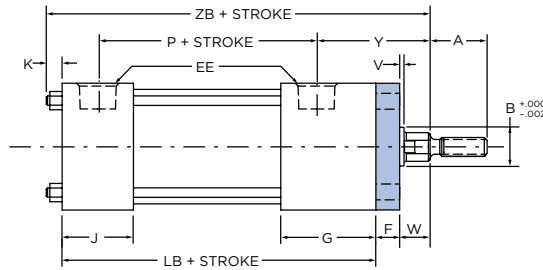
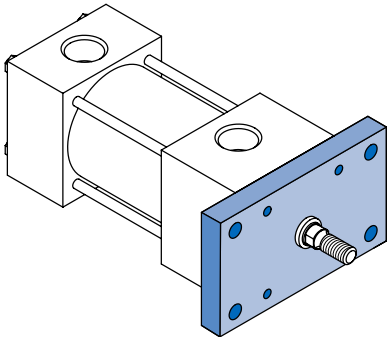

**PRESSURE LIMITATIONS (PUSH)**

CYL. DIAMETER	5	6	7	8
PRESSURE (PSI)	1800	1500	1000	800

Use Model DD (below) or Model G (page 34) for Recommended Maximum Pressure.

**MODEL DD (NFPA STD. MF5)**

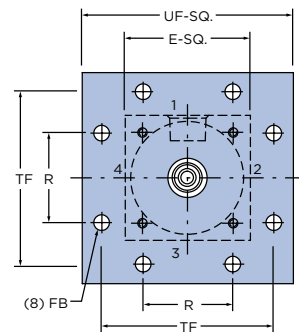
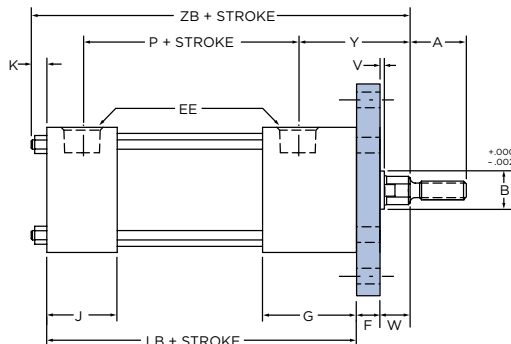
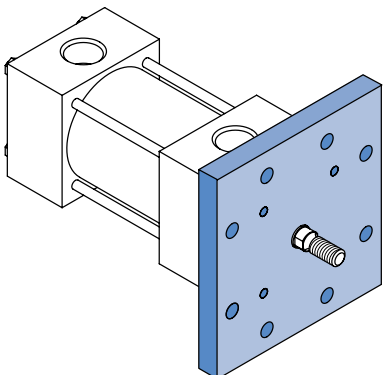

▲ = See Table A on page 57 for bore and rod combinations using head plates with threaded bronze glands.

# FLANGE MOUNT CYLINDERS

1-1/2" THROUGH 8" BORE

**Table 1** These dimensions are constant regardless of rod diameter or stroke.

Double rod end models are designated by letter "X" preceding the model identification. See page 56.

• = Dimensions refer to bolt diameter.

BORE DIA.	E	F	G	J	K	R	EE	FB•	TF	UF
1-1/2	2-1/2	3/8	1-3/4	1-1/2	1/2	1.63	1/2	3/8	3-7/16	4-1/4
2	3	5/8	1-3/4	1-1/2	1/2	2.05	1/2	1/2	4-1/8	5-1/8
2-1/2	3-1/2	5/8	1-3/4	1-1/2	5/8	2.55	1/2	1/2	4-5/8	5-5/8
3-1/4	4-1/2	3/4	2-1/4	1-3/4	3/4	3.25	3/4	5/8	5-7/8	7-1/8
4	5	7/8	2-1/4	1-3/4	3/4	3.82	3/4	5/8	6-3/8	7-5/8
5	6-1/2	7/8	2-1/4	1-3/4	1	4.95	3/4	7/8	8-3/16	9-3/4
6	7-1/2	1	2-1/2	2-1/4	1-1/8	5.73	1	1	9-7/16	11-1/4
7	8-1/2	1	2-3/4	2-3/4	1-1/8	6.58	1-1/4	1-1/8	10-5/8	12-5/8
8	9-1/2	1	3	3	1-3/8	7.50	1-1/2	1-1/4	11-13/16	14

**Table 2** The dimensions given on this table are affected by the piston rod diameter and the stroke.

• = For piston rod dimensions see page 60.

BORE DIA.	ROD MM•	A	B	P	V	W	Y	LB	WF	ZB	ZF
1-1/2	5/8	3/4	1-1/8	2-3/4	1/4	5/8	2-1/16	4-5/8	1	6-1/8	6
	1	1-1/8	1-1/2	2-3/4	1/2	1	2-7/16	4-5/8	1-3/8	6-1/2	6-3/8
2	1	1-1/8	1-1/2	2-3/4	1/4	3/4	2-7/16	4-5/8	1-3/8	6-1/2	6-5/8
	1-3/8	1-5/8	2	2-3/4	3/8	1	2-11/16	4-5/8	1-5/8	6-3/4	6-7/8
2-1/2	1	1-1/8	1-1/2	2-7/8	1/4	3/4	2-7/16	4-3/4	1-3/8	6-3/4	6-3/4
	1-3/8	1-5/8	2	2-7/8	3/8	1	2-11/16	4-3/4	1-5/8	7	7
	1-3/4	2	2-3/8	2-7/8	1/2	1-1/4	2-15/16	4-3/4	1-7/8	7-1/4	7-1/4
3-1/4	1-3/8	1-5/8	2	3-1/4	1/4	7/8	3	5-1/2	1-5/8	7-7/8	7-7/8
	1-3/4	2	2-3/8	3-1/4	3/8	1-1/8	3-1/4	5-1/2	1-7/8	8-1/8	8-1/8
	2	2-1/4	2-5/8	3-1/4	3/8	1-1/4	3-3/8	5-1/2	2	8-1/4	8-1/4
4	1-3/4	2	2-3/8	3-1/2	1/4	1	3-1/4	5-3/4	1-7/8	8-3/8	8-1/2
	2	2-1/4	2-5/8	3-1/2	1/4	1-1/8	3-3/8	5-3/4	2	8-1/2	8-5/8
	2-1/2	3	3-1/8	3-1/2	3/8	1-3/8	3-5/8	5-3/4	2-1/4	8-3/4	8-7/8
5	2	2-1/4	2-5/8	4	1/4	1-1/8	3-3/8	6-1/4	2	9-1/4	9-1/8
	2-1/2	3	3-1/8	4	3/8	1-3/8	3-5/8	6-1/4	2-1/4	9-1/2	9-3/8
	3	3-1/2	3-3/4	4	3/8	1-3/8	3-5/8	6-1/4	2-1/4	9-1/2	9-3/8
	3-1/2	3-1/2	4-1/4	4	3/8	1-3/8	3-5/8	6-1/4	2-1/4	9-1/2	9-3/8
6	2-1/2	3	3-1/8	4-5/8	1/4	1-1/4	3-3/4	7-3/8	2-1/4	10-3/4	10-5/8
	3	3-1/2	3-3/4	4-5/8	1/4	1-1/4	3-3/4	7-3/8	2-1/4	10-3/4	10-5/8
	3-1/2	3-1/2	4-1/4	4-5/8	1/4	1-1/4	3-3/4	7-3/8	2-1/4	10-3/4	10-5/8
	4	4	4-3/4	4-5/8	1/4	1-1/4	3-3/4	7-3/8	2-1/4	10-3/4	10-5/8
7	3	3-1/2	3-3/4	5-3/8	1/4	1-1/4	3-13/16	8-1/2	2-1/4	11-7/8	11-3/4
	3-1/2	3-1/2	4-1/4	5-3/8	1/4	1-1/4	3-13/16	8-1/2	2-1/4	11-7/8	11-3/4
	4	4	4-3/4	5-3/8	1/4	1-1/4	3-13/16	8-1/2	2-1/4	11-7/8	11-3/4
	4-1/2	4-1/2	5-1/4	5-3/8	1/4	1-1/4	3-13/16	8-1/2	2-1/4	11-7/8	11-3/4
	5	5	5-3/4	5-3/8	1/4	1-1/4	3-13/16	8-1/2	2-1/4	11-7/8	11-3/4
8	3-1/2	3-1/2	4-1/4	6	1/4	1-1/4	4	9-1/2	2-1/4	13-1/8	12-3/4
	4	4	4-3/4	6	1/4	1-1/4	4	9-1/2	2-1/4	13-1/8	12-3/4
	4-1/2	4-1/2	5-1/4	6	1/4	1-1/4	4	9-1/2	2-1/4	13-1/8	12-3/4
	5	5	5-3/4	6	1/4	1-1/4	4	9-1/2	2-1/4	13-1/8	12-3/4
	5-1/2	5-1/2	6-1/4	6	1/4	1-1/4	4	9-1/2	2-1/4	13-1/8	12-3/4

**MODEL CC (BLIND END FLANGE MOUNT) 10" THROUGH 12" DIAMETER BORE**

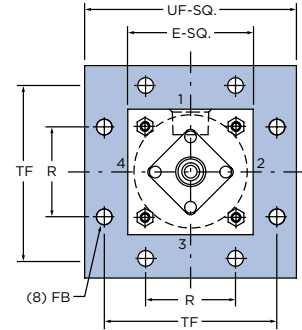
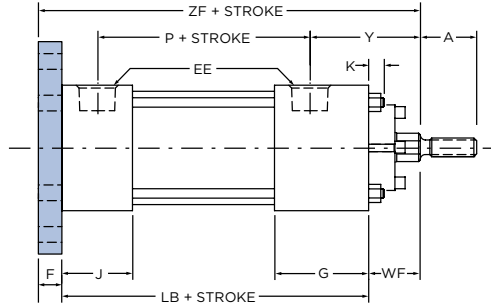
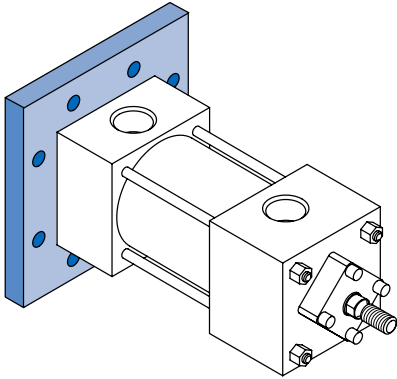

**MODEL CJ (BLIND HEAD SQUARE MOUNT) 14" THROUGH 20" DIAMETER BORE**

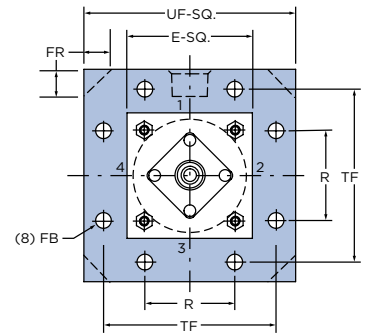
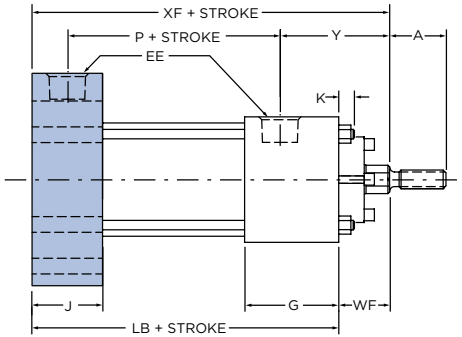
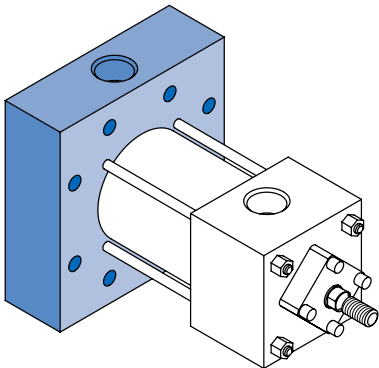

**MODEL DD (ROD END FLANGE MOUNT) 10" THROUGH 12" DIAMETER BORE**

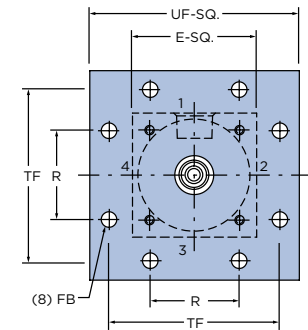
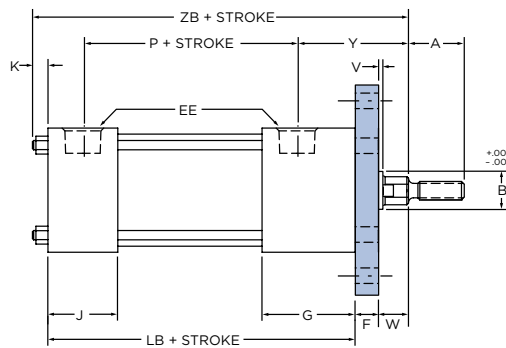
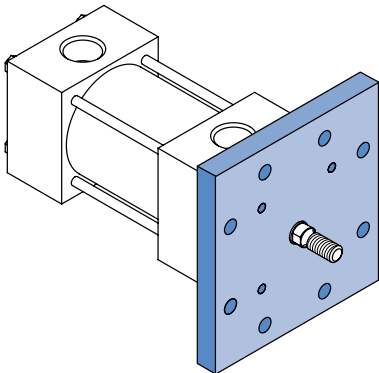

**MODEL DG (ROD HEAD SQUARE MOUNT) 14" THROUGH 20" DIAMETER BORE**

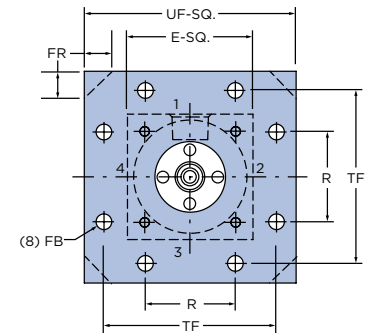
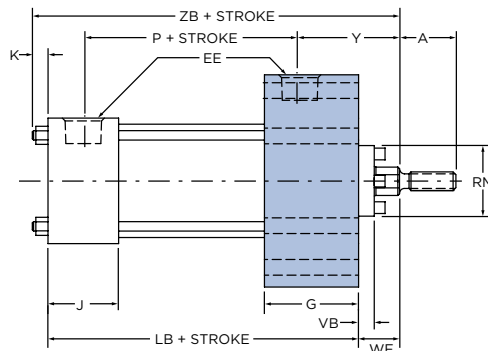
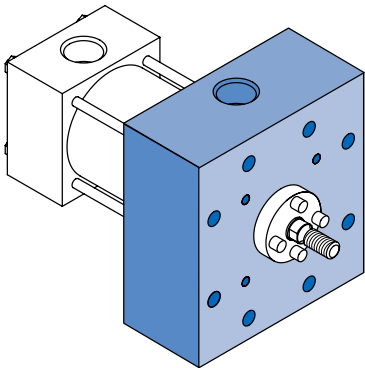



# FLANGE AND SQUARE-HEAD MOUNT CYLINDERS

10" THROUGH 20" BORE

**Table 1** These dimensions are constant regardless of rod diameter or stroke.

Double rod end models are designated by letter "X" preceding the model identification. See page 56.  
• = Dimensions refer to bolt diameter.

BORE DIA.	E	F	G	J	K	R	EE	FB•	FR	TF	UF
10	12-5/8	1-11/16	3-11/16	3-11/16	1-1/8	9.62	2	1-3/4	-	15-7/8	19
12	14-7/8	1-15/16	4-7/16	4-7/16	1-1/8	11.45	2-1/2	2	-	18-1/2	22
14	17-1/4	-	4-7/8	4-7/8	1-7/16	13.34	2-1/2	2-1/4	-	21	25
16	19-1/4	-	5-7/8	5-7/8	1-7/16	15.10	3	2-1/2	-	23-7/8	28-3/8
18	22	-	6-7/8	6-7/8	1-7/16	16.88	3	2-3/4	4	26-1/4	31
20	23-5/8	-	7-7/8	7-7/8	1-7/16	18.74	3	3	6	29	34-1/2

**Table 2** The dimensions given on this table are affected by the piston rod diameter and the stroke.

• = For piston rod dimensions see page 60.

BORE DIA.	ROD MM•	A	B	P	V	W	Y	LB	RM	VB	WF	XF	ZB	ZF
10	4-1/2	4-1/2	5-1/4	8	1/4	1-1/4	5	12-1/8	7-3/4	-	2-15/16	15-1/16	16-3/16	16-3/4
	5	5	5-3/4	8	1/4	1-1/2	5-1/4	12-1/8	8-3/8	-	3-3/16	15-5/16	16-7/16	17
	5-1/2	5-1/2	6-1/4	8	1/4	1-1/2	5-1/4	12-1/8	9	-	3-3/16	15-5/16	16-7/16	17
	7	7	10-1/4	8	11/16	1-1/2	5-1/4	12-1/8	10-1/4	2-3/8	3-3/16	15-5/16	16-7/16	17
12	5-1/2	5-1/2	6-1/4	9-5/8	1/4	1-1/4	5-5/8	14-1/2	9	-	3-3/16	17-11/16	18-13/16	19-5/8
	7	7	10-1/4	9-5/8	7/16	1-1/2	5-7/8	14-1/2	10-1/4	2-3/8	3-7/16	17-15/16	19-1/16	19-7/8
	8	8	11-1/4	9-5/8	7/16	1-1/2	5-7/8	14-1/2	11-1/4	2-3/8	3-7/16	17-15/16	19-1/16	19-7/8
14	7	7	-	9-7/8	-	-	6-3/8	15-5/8	10-1/4	2-3/8	3-1/2	19-1/8	20-1/4	21-3/8
	8	8	-	9-7/8	-	-	6-3/8	15-5/8	11-1/4	2-3/8	3-1/2	19-1/8	20-1/4	21-3/8
	10	10	-	9-7/8	-	-	6-3/8	15-5/8	14	2-1/2	3-1/2	19-1/8	20-1/4	21-3/8
16	8	8	-	11-3/8	-	-	7-3/8	18-1/8	11-1/4	2-3/8	4	22-1/4	23-9/16	24-7/8
	9	9	-	11-3/8	-	-	7-3/8	18-1/8	12-1/2	2-1/2	4	22-1/4	23-9/16	24-7/8
	10	10	-	11-3/8	-	-	7-3/8	18-1/8	14	2-1/2	4	22-1/4	23-9/16	24-7/8
18	9	9	-	12-3/8	-	-	8-5/8	21-1/8	12-1/2	2-1/2	4-1/4	25-3/8	26-13/16	28-3/8
	10	10	-	12-3/8	-	-	8-5/8	21-1/8	14	2-1/2	4-1/4	25-3/8	26-13/16	28-3/8
20	10	10	-	13-3/8	-	-	9-5/8	23-5/8	14	2-1/2	4-1/2	28-1/8	29-9/16	31-3/8

**MODEL G (NFPA STD. ME5)**

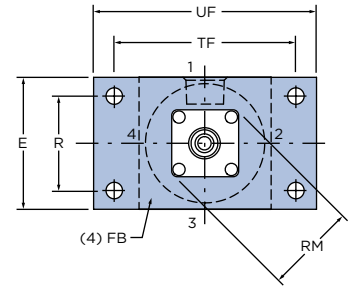
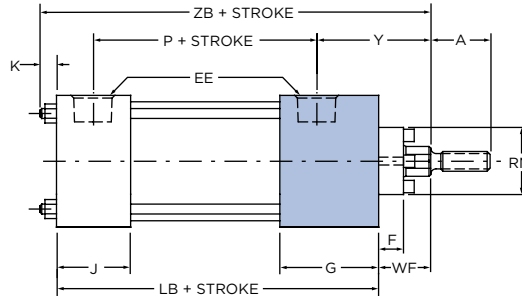
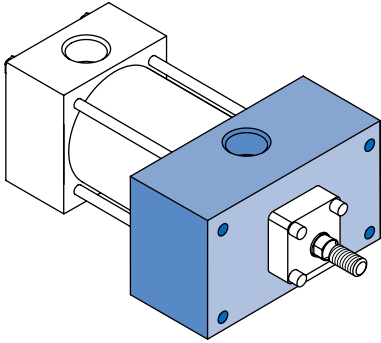

**MODEL J (NFPA STD. ME6)▲**

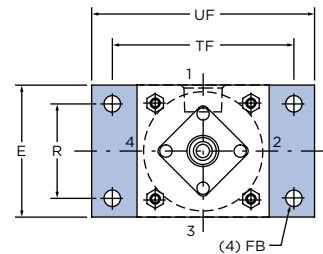
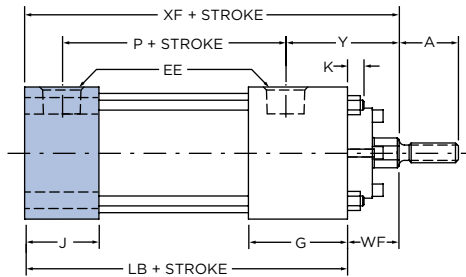
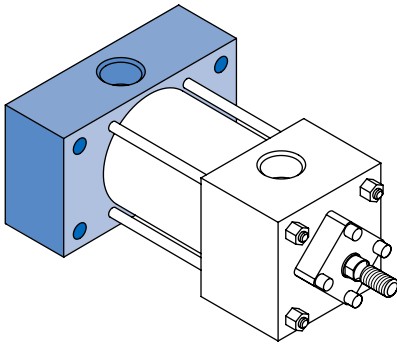

▲ = See Table A on page 57 for bore and rod combinations using head plates with threaded bronze glands.

**Table 1** These dimensions are constant regardless of rod diameter or stroke.

Double rod end models are designated by letter "X" preceding the model identification. See page 56.

• = Dimensions refer to bolt diameter.

BORE DIA.	E	G	J	K	R	EE	FB•	TF	UF
1-1/2	2-1/2	1-3/4	1-1/2	1/2	1.63	1/2	3/8	3-7/16	4-1/4
2	3	1-3/4	1-1/2	1/2	2.05	1/2	1/2	4-1/8	5-1/8
2-1/2	3-1/2	1-3/4	1-1/2	5/8	2.55	1/2	1/2	4-5/8	5-5/8
3-1/4	4-1/2	2-1/4	1-3/4	3/4	3.25	3/4	5/8	5-7/8	7-1/8
4	5	2-1/4	1-3/4	3/4	3.82	3/4	5/8	6-3/8	7-5/8
5	6-1/2	2-1/4	1-3/4	1	4.95	3/4	7/8	8-3/16	9-3/4
6	7-1/2	2-1/2	2-1/4	1-1/8	5.73	1	1	9-7/16	11-1/4
7	8-1/2	2-3/4	2-3/4	1-1/4	6.58	1-1/4	1-1/8	10-5/8	12-5/8
8	9-1/2	3	3	1-1/2	7.50	1-1/2	1-1/4	11-13/16	14
10	12-5/8	3-11/16	3-11/16	1-1/8	9.62	2	1-3/4	15-7/8	19
12	14-7/8	4-7/16	4-7/16	1-1/8	11.45	2-1/2	2	18-1/2	22

# ROD HEAD AND BLIND HEAD RECTANGULAR MOUNT CYLINDERS

1-1/2" THROUGH 12" DIAMETER

**Table 2** The dimensions given on this table are affected by the piston rod diameter and the stroke.

• = For piston rod dimensions see page 60.

BORE DIA.	ROD MM•	A	F	P	Y	LB	RM	WF	XF	ZB
1-1/2	5/8	3/4	3/8	2-3/4	2-1/16	4-5/8	2-1/8	1	5-5/8	6-1/8
	1	1-1/8	1/2	2-3/4	2-7/16	4-5/8	2-3/8	1-3/8	6	6-1/2
2	1	1-1/8	1/2	2-3/4	2-7/16	4-5/8	2-3/8	1-3/8	6	6-1/2
	1-3/8	1-5/8	9/16	2-3/4	2-11/16	4-5/8	3	1-5/8	6-1/4	6-3/4
2-1/2	1	1-1/8	1/2	2-7/8	2-7/16	4-3/4	2-3/8	1-3/8	6-1/8	6-3/4
	1-3/8	1-5/8	9/16	2-7/8	2-11/16	4-3/4	3	1-5/8	6-3/8	7
	1-3/4	2	9/16	2-7/8	2-15/16	4-3/4	3-1/2	1-7/8	6-5/8	7-1/4
3-1/4	1-3/8	1-5/8	9/16	3-1/4	3	5-1/2	3	1-5/8	7-1/8	7-7/8
	1-3/4	2	9/16	3-1/4	3-1/4	5-1/2	3-1/2	1-7/8	7-3/8	8-1/8
	2	2-1/4	9/16	3-1/4	3-3/8	5-1/2	4-1/8	2	7-1/2	8-1/4
4	1-3/4	2	9/16	3-1/2	3-1/4	5-3/4	3-1/2	1-7/8	7-5/8	8-3/8
	2	2-1/4	9/16	3-1/2	3-3/8	5-3/4	4-1/8	2	7-3/4	8-1/2
	2-1/2	3	3/4	3-1/2	3-5/8	5-3/4	4-5/8	2-1/4	8	8-3/4
5	2	2-1/4	9/16	4	3-3/8	6-1/4	4-1/8	2	8-1/4	9-1/4
	2-1/2	3	3/4	4	3-5/8	6-1/4	4-5/8	2-1/4	8-1/2	9-1/2
	3	3-1/2	3/4	4	3-5/8	6-1/4	5-1/2	2-1/4	8-1/2	9-1/2
	3-1/2	3-1/2	3/4	4	3-5/8	6-1/4	6-1/8	2-1/4	8-1/2	9-1/2
6	2-1/2	3	3/4	4-5/8	3-3/4	7-3/8	4-5/8	2-1/4	9-5/8	10-3/4
	3	3-1/2	3/4	4-5/8	3-3/4	7-3/8	5-1/2	2-1/4	9-5/8	10-3/4
	3-1/2	3-1/2	3/4	4-5/8	3-3/4	7-3/8	6-1/8	2-1/4	9-5/8	10-3/4
	4	4	13/16	4-5/8	3-3/4	7-3/8	6-7/8	2-1/4	9-5/8	10-3/4
7	3	3-1/2	3/4	5-3/8	3-13/16	8-1/2	5-1/2	2-1/4	10-3/4	11-7/8
	3-1/2	3-1/2	3/4	5-3/8	3-13/16	8-1/2	6-1/8	2-1/4	10-3/4	11-7/8
	4	4	13/16	5-3/8	3-13/16	8-1/2	6-7/8	2-1/4	10-3/4	11-7/8
	4-1/2	4-1/2	13/16	5-3/8	3-13/16	8-1/2	7-3/4	2-1/4	10-3/4	11-7/8
	5	5	15/16	5-3/8	3-13/16	8-1/2	8-3/8	2-1/4	10-3/4	11-7/8
8	3-1/2	3-1/2	3/4	6	4	9-1/2	6-1/8	2-1/4	11-3/4	13-1/8
	4	4	13/16	6	4	9-1/2	6-7/8	2-1/4	11-3/4	13-1/8
	4-1/2	4-1/2	13/16	6	4	9-1/2	7-3/4	2-1/4	11-3/4	13-1/8
	5	5	15/16	6	4	9-1/2	8-3/8	2-1/4	11-3/4	13-1/8
	5-1/2	5-1/2	15/16	6	4	9-1/2	9	2-1/4	11-3/4	13-1/8
10	4-1/2	4-1/2	13/16	8	5	12-1/8	7-3/4	2-15/16	15-1/16	16-3/16
	5	5	15/16	8	5-1/4	12-1/8	8-3/8	3-3/16	15-5/16	16-7/16
	5-1/2	5-1/2	15/16	8	5-1/4	12-1/8	9	3-3/16	15-5/16	16-7/16
	7	7	2-3/16	8	5-1/4	12-1/8	10-1/4	3-3/16	15-5/16	16-7/16
12	5-1/2	5-1/2	15/16	9-5/8	5-5/8	14-1/2	9	3-3/16	17-11/16	18-13/16
	7	7	2-3/16	9-5/8	5-7/8	14-1/2	10-1/4	3-7/16	17-15/16	19-1/16
	8	8	2-7/16	9-5/8	5-7/8	14-1/2	11-1/4	3-7/16	17-15/16	19-1/16

**MODEL A (NFPA STD. MS2)** ▲

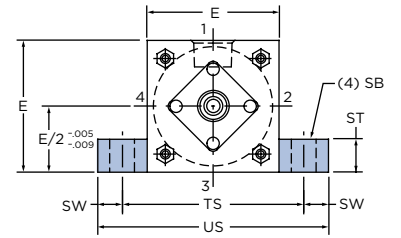
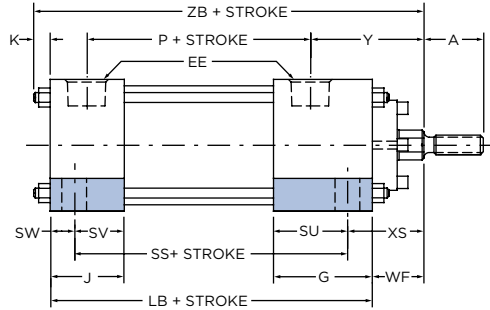
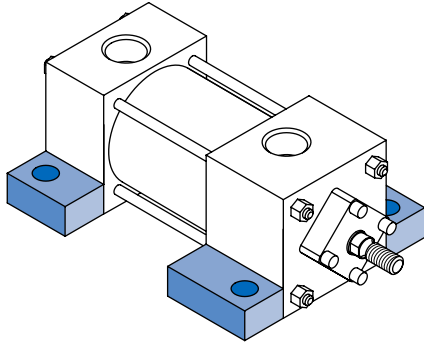

**MODEL B (NFPA STD. MS3)** ▲

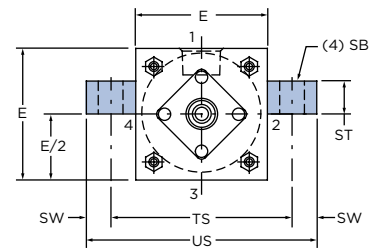
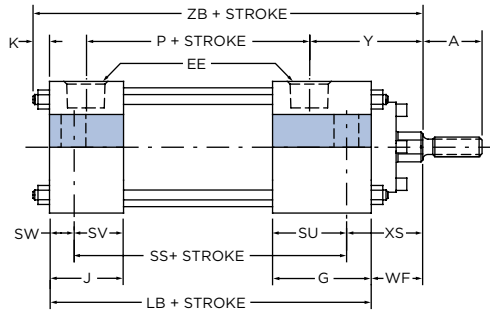
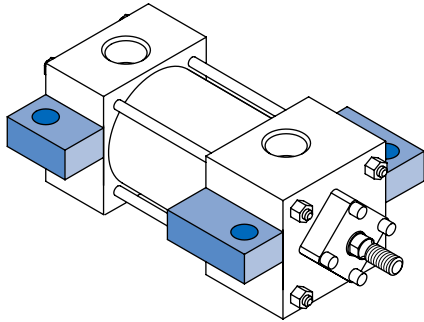

**MODEL S (NFPA STD. MS4)**

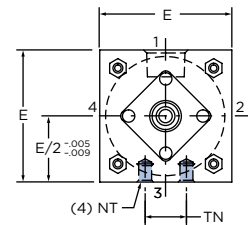
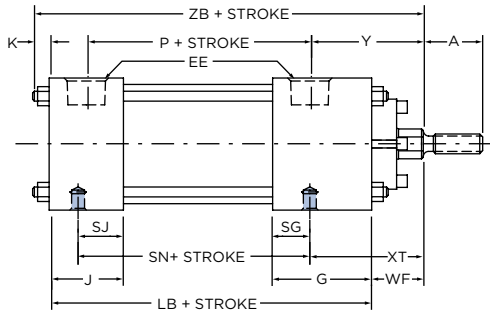
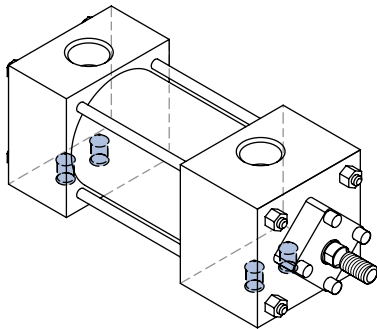

▲ = See Table A on page 57 for bore and rod combinations using head plates with threaded bronze glands.

# SIDE AND LUG MOUNT CYLINDERS

1-1/2" THROUGH 7" DIAMETER

**Table 1** These dimensions are constant regardless of rod diameter or stroke.

For double rod end cylinders Model A and B: subtract dimensions SV from SU and add to dimension SS + Stroke. See pages 56-59.  
Double rod end models are designated by letter "X" preceding the model identification. See page 56.

• = Dimensions refer to bolt diameter.

BORE DIA.	E	G	J	K	EE	NT	SB•	SG	SJ	ST	SU	SV	SW	TN	TS	US
1-1/2	2-1/2	1-3/4	1-1/2	1/2	1/2	3/8-16	3/8	3/4	3/4	1/2	1-3/8	1-1/8	3/8	3/4	3-1/4	4
2	3	1-3/4	1-1/2	1/2	1/2	1/2-13	1/2	3/4	3/4	3/4	1-1/4	1	1/2	15/16	4	5
2-1/2	3-1/2	1-3/4	1-1/2	5/8	1/2	5/8-11	3/4	3/4	3/4	1	1-1/16	13/16	11/16	1-5/16	4-7/8	6-1/4
3-1/4	4-1/2	2-1/4	1-3/4	3/4	3/4	3/4-10	3/4	1-1/8	7/8	1	1-9/16	1-1/16	11/16	1-1/2	5-7/8	7-1/4
4	5	2-1/4	1-3/4	3/4	3/4	1-8	1	1-1/8	7/8	1-1/4	1-3/8	7/8	7/8	2-1/16	6-3/4	8-1/2
5	6-1/2	2-1/4	1-3/4	1	3/4	1-8	1	1-1/8	7/8	1-1/4	1-3/8	7/8	7/8	2-15/16	8-1/4	10
6	7-1/2	2-1/2	2-1/4	1-1/8	1	1-1/4-7	1-1/4	1-1/4	1-1/4	1-1/2	1-3/8	1-1/8	1-1/8	3-5/16	9-3/4	12
7	8-1/2	2-3/4	2-3/4	1-1/8	1-1/4	1-1/2-6	1-1/2	1-13/16	1-11/16	1-3/4	1-3/8	1-3/8	1-3/8	3-3/4	11-1/4	14

**Table 2** The dimensions given on this table are affected by the piston rod diameter and the stroke.

For double rod end cylinders Model S: in place of dimension SN + stroke, multiply dimension XT times 2 and to this total add the cylinder stroke. From this figure, subtract the ZM + double stroke. See pages 56-59.

• = For piston rod dimensions see page 60.

BORE DIA.	ROD MM•	A	P	Y	LB	SN	SS	WF	XS	XT	ZB
1-1/2	5/8	3/4	2-3/4	2-1/16	4-5/8	2-7/8	3-7/8	1	1-3/8	2	6-1/8
	1	1-1/8	2-3/4	2-7/16	4-5/8	-	3-7/8	1-3/8	1-3/4	-	6-1/2
2	1	1-1/8	2-3/4	2-7/16	4-5/8	2-7/8	3-5/8	1-3/8	1-7/8	2-3/8	6-1/2
	1-3/8	1-5/8	2-3/4	2-11/16	4-5/8	-	3-5/8	1-5/8	2-1/8	-	6-3/4
2-1/2	1	1-1/8	2-7/8	2-7/16	4-3/4	3	3-3/8	1-3/8	2-1/16	2-3/8	6-3/4
	1-3/8	1-5/8	2-7/8	2-11/16	4-3/4	-	3-3/8	1-5/8	2-5/16	-	7
	1-3/4	2	2-7/8	2-15/16	4-3/4	-	3-3/8	1-7/8	2-9/16	-	7-1/4
3-1/4	1-3/8	1-5/8	3-1/4	3	5-1/2	3-1/2	4-1/8	1-5/8	2-5/16	2-3/4	7-7/8
	1-3/4	2	3-1/4	3-1/4	5-1/2	-	4-1/8	1-7/8	2-9/16	-	8-1/8
	2	2-1/4	3-1/4	3-3/8	5-1/2	-	4-1/8	2	2-11/16	-	8-1/4
4	1-3/4	2	3-1/2	3-1/4	5-3/4	3-3/4	4	1-7/8	2-3/4	3	8-3/8
	2	2-1/4	3-1/2	3-3/8	5-3/4	-	4	2	2-7/8	-	8-1/2
	2-1/2	3	3-1/2	3-5/8	5-3/4	-	4	2-1/4	3-1/8	-	8-3/4
5	2	2-1/4	4	3-3/8	6-1/4	4-1/4	4-1/2	2	2-7/8	3-1/8	9-1/4
	2-1/2	3	4	3-5/8	6-1/4	-	4-1/2	2-1/4	3-1/8	-	9-1/2
	3	3-1/2	4	3-5/8	6-1/4	-	4-1/2	2-1/4	3-1/8	-	9-1/2
	3-1/2	3-1/2	4	3-5/8	6-1/4	-	4-1/2	2-1/4	3-1/8	-	9-1/2
6	2-1/2	3	4-5/8	3-3/4	7-3/8	5-1/8	5-1/8	2-1/4	3-3/8	3-1/2	10-3/4
	3	3-1/2	4-5/8	3-3/4	7-3/8	-	5-1/8	2-1/4	3-3/8	-	10-3/4
	3-1/2	3-1/2	4-5/8	3-3/4	7-3/8	-	5-1/8	2-1/4	3-3/8	-	10-3/4
	4	4	4-5/8	3-3/4	7-3/8	-	5-1/8	2-1/4	3-3/8	-	10-3/4
7	3	3-1/2	5-3/8	3-13/16	8-1/2	5-7/8	5-3/4	2-1/4	3-5/8	3-13/16	11-7/8
	3-1/2	3-1/2	5-3/8	3-13/16	8-1/2	-	5-3/4	2-1/4	3-5/8	-	11-7/8
	4	4	5-3/8	3-13/16	8-1/2	-	5-3/4	2-1/4	3-5/8	-	11-7/8
	4-1/2	4-1/2	5-3/8	3-13/16	8-1/2	-	5-3/4	2-1/4	3-5/8	-	11-7/8
	5	5	5-3/8	3-13/16	8-1/2	-	5-3/4	2-1/4	3-5/8	-	11-7/8

**MODEL A** (NFPA STD. MS2) 8" THROUGH 14" DIAMETER BORE

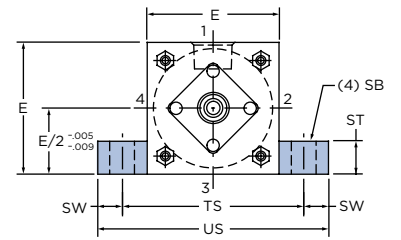
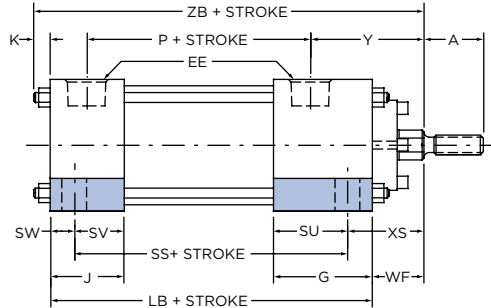
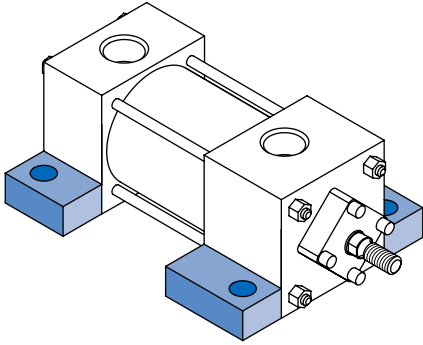

**MODEL B** (NFPA STD. MS3) 8" THROUGH 20" DIAMETER BORE

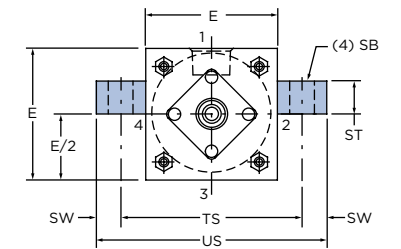
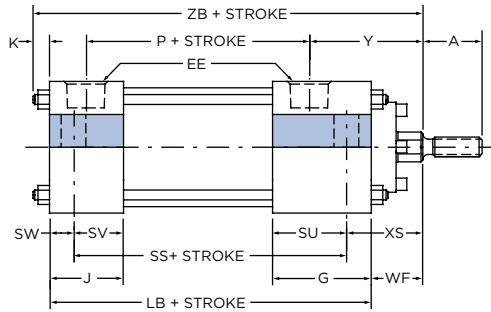
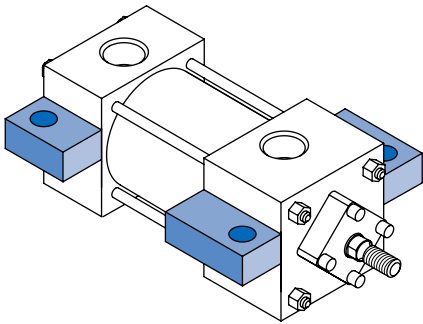

**MODEL S** (NFPA STD. MS4) 8" DIAMETER BORE

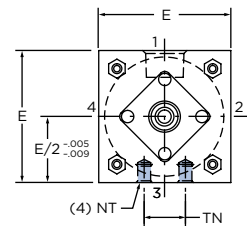
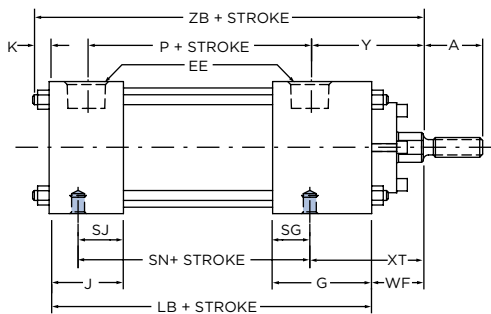
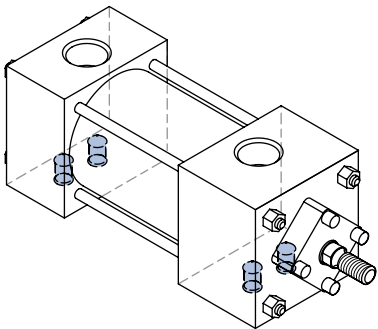

**NOTE:** This model available in small rod only.

# SIDE AND LUG MOUNT CYLINDERS

8" THROUGH 20" DIAMETER

**Table 1** These dimensions are constant regardless of rod diameter or stroke.

For double rod end cylinders Model A and B: subtract dimension SV from SU and add to dimension SS + stroke. See pages 56-59. Double rod end models are designated by letter "X" preceding the model identification. See page 56.

• = Dimensions refer to bolt diameter.

BORE DIA.	E	G	J	K	EE	NT	SB•	SG	SJ	ST	SU	SV	SW	TN	TS	US
8	9-1/2	3	3	1-3/8	1-1/2	1-1/2-6	1-1/2	1-5/16	1-13/16	1-3/4	1-5/8	1-5/8	1-3/8	4-1/4	12-1/4	15
10	12-5/8	3-11/16	3-11/16	1-1/8	2	-	1-1/2	-	-	2-1/4	2-1/16	2-1/16	1-5/8	-	15-7/8	19-1/8
12	14-7/8	4-7/16	4-7/16	1-1/8	2-1/2	-	1-1/2	-	-	3	2-7/16	2-7/16	2	-	18-7/8	22-7/8
14	17-1/4	4-7/8	4-7/8	1-7/16	2-1/2	-	2-1/4	-	-	4	2-5/8	2-5/8	2-1/4	-	21-3/4	26-1/4
16	19-1/4	5-7/8	5-7/8	1-7/16	3	-	2-1/2	-	-	4-1/2	3-1/8	3-1/8	2-1/2	-	24-1/4	29-1/4
18	22	6-7/8	6-7/8	1-7/16	3	-	2-3/4	-	-	5-1/4	3-5/8	3-5/8	2-3/4	-	27-1/2	33
20	23-5/8	7-7/8	7-7/8	1-7/16	3	-	3	-	-	6-1/2	4	4	3-1/4	-	30-1/8	36-5/8

**Table 2** The dimensions given on this table are affected by the piston rod diameter and the stroke.

For double rod end cylinders Model S: in place of dimension SN + stroke, multiply dimension XT times 2 and to this total add the cylinder stroke. From this figure, subtract the ZM + double stroke. See pages 56-59.

• = For piston rod dimensions see page 60.

BORE DIA.	ROD MM•	A	P	Y	LB	SN	SS	WF	XS	XT	ZB
8	3-1/2	3-1/2	6	4	9-1/2	6-5/8	6-3/4	2-1/4	3-5/8	3-15/16	13-1/8
	4	4	6	4	9-1/2	-	6-3/4	2-1/4	3-5/8	-	13-1/8
	4-1/2	4-1/2	6	4	9-1/2	-	6-3/4	2-1/4	3-5/8	-	13-1/8
	5	5	6	4	9-1/2	-	6-3/4	2-1/4	3-5/8	-	13-1/8
	5-1/2	5-1/2	6	4	9-1/2	-	6-3/4	2-1/4	3-5/8	-	13-1/8
10	4-1/2	4-1/2	8	5	12-1/8	-	8-7/8	2-15/16	4-9/16	-	16-3/16
	5	5	8	5-1/4	12-1/8	-	8-7/8	3-3/16	4-13/16	-	16-7/16
	5-1/2	5-1/2	8	5-1/4	12-1/8	-	8-7/8	3-3/16	4-13/16	-	16-7/16
	7	7	8	5-1/4	12-1/8	-	8-7/8	3-3/16	4-13/16	-	16-7/16
12	5-1/2	5-1/2	9-5/8	5-5/8	14-1/2	-	10-1/2	3-3/16	5-3/16	-	18-13/16
	7	7	9-5/8	5-7/8	14-1/2	-	10-1/2	3-7/16	5-7/16	-	19-1/16
	8	8	9-5/8	5-7/8	14-1/2	-	10-1/2	3-7/16	5-7/16	-	19-1/16
14	7	7	9-7/8	6-3/8	15-5/8	-	11-1/8	3-1/2	5-3/4	-	20-1/4
	8	8	9-7/8	6-3/8	15-5/8	-	11-1/8	3-1/2	5-3/4	-	20-1/4
	10	10	9-7/8	6-3/8	15-5/8	-	11-1/8	3-1/2	5-3/4	-	20-1/4
16	8	8	11-3/8	7-3/8	18-1/8	-	12-5/8	4	6-3/4	-	23-9/16
	9	9	11-3/8	7-3/8	18-1/8	-	12-5/8	4	6-3/4	-	23-9/16
	10	10	11-3/8	7-3/8	18-1/8	-	12-5/8	4	6-3/4	-	23-9/16
18	9	9	12-3/8	8-5/8	21-1/8	-	14-5/8	4-1/4	7-1/2	-	26-13/16
	10	10	12-3/8	8-5/8	21-1/8	-	14-5/8	4-1/4	7-1/2	-	26-13/16
20	10	10	13-3/8	9-5/8	23-5/8	-	15-7/8	4-1/2	8-3/8	-	29-9/16

**MODEL AL (NFPA STD. MS7)**

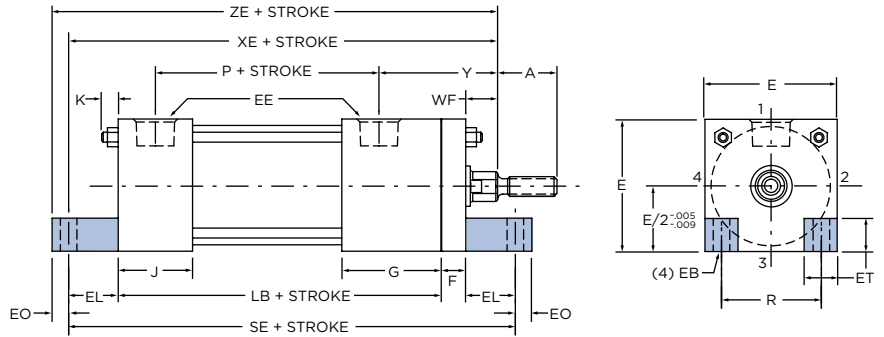
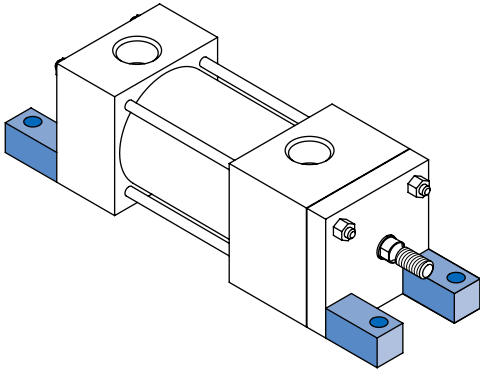

**MODEL E (NFPA STD. MP1)▲**

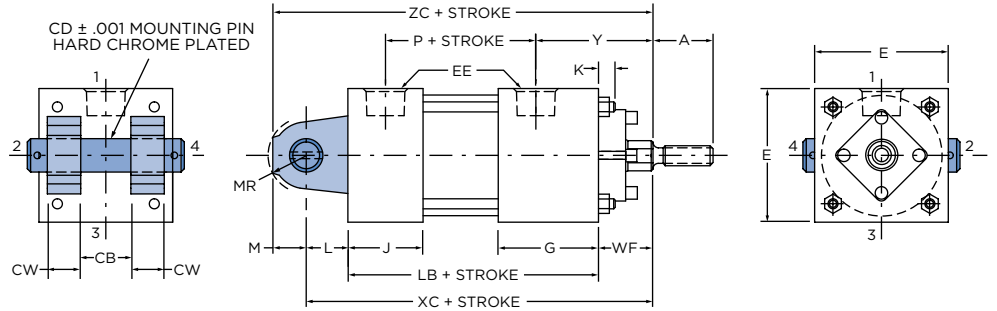
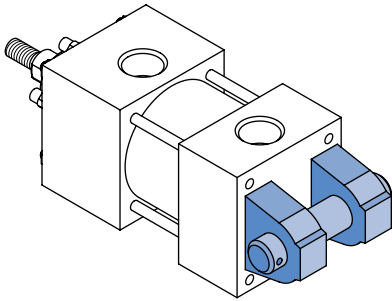

**NOTE:** Pin  $\varnothing$  is CD. Swing radius is MR.

**MODEL HE (NFPA STD. MP2)▲ 1-1/2" THROUGH 7" DIAMETER BORE**

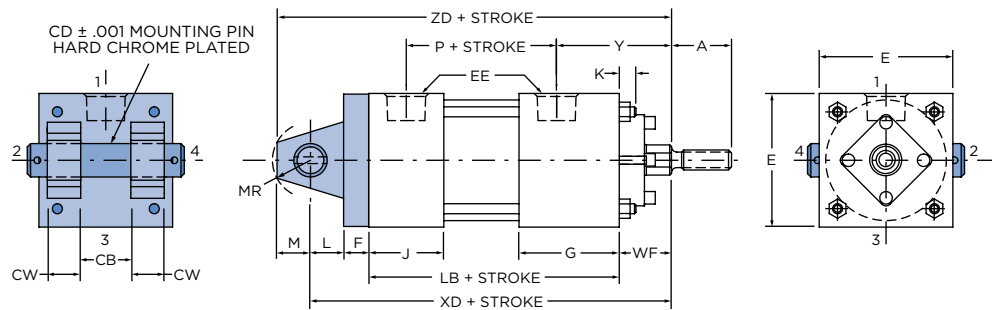
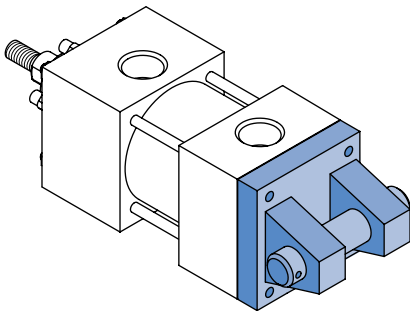

**NOTE:** Pin  $\varnothing$  is CD. Swing radius is MR.

▲ = See Table A on page 57 for bore and rod combinations using head plates with threaded bronze glands.



# END LUG AND CLEVIS MOUNT CYLINDERS

1-1/2" THROUGH 7" DIAMETER

**Table 1** These dimensions are constant regardless of rod diameter or stroke.

For double rod end cylinders Model AL: subtract dimension J from G and add to dimension SE + stroke.  
Double rod end models are designated by letter "X" preceding the model identification. See page 56.

• = Dimensions refer to bolt diameter.

BORE DIA.	E	F		G	J	K	L	M	R	CB	CD	CW	EB•	EE	EL	EO	ET	MR
		AL	HE															
1-1/2	2-1/2	3/8	3/8	1-3/4	1-1/2	1/2	3/4	1/2	1.81	3/4	1/2	1/2	3/8	1/2	7/8	3/8	11/16	5/8
2	3	5/8	5/8	1-3/4	1-1/2	1/2	1-1/4	3/4	2.19	1-1/4	3/4	5/8	1/2	1/2	15/16	1/2	13/16	7/8
2-1/2	3-1/2	5/8	5/8	1-3/4	1-1/2	5/8	1-1/4	3/4	2.55	1-1/4	3/4	5/8	1/2	1/2	15/16	1/2	15/16	7/8
3-1/4	4-1/2	3/4	7/8	2-1/4	1-3/4	3/4	1-1/2	1	3.25	1-1/2	1	3/4	5/8	3/4	1-1/8	5/8	1-1/4	1-1/4
4	5	7/8	7/8	2-1/4	1-3/4	3/4	2-1/8	1-3/8	3.82	2	1-3/8	1	5/8	3/4	1-1/8	5/8	1-3/16	1-5/8
5	6-1/2	7/8	1-1/8	2-1/4	1-3/4	1	2-1/4	1-3/4	4.95	2-1/2	1-3/4	1-1/4	7/8	3/4	1-1/2	3/4	1-9/16	2
6	7-1/2	1	1-7/16	2-1/2	2-1/4	1-1/8	2-1/2	2	5.73	2-1/2	2	1-1/4	1	1	1-11/16	7/8	1-3/4	2-3/8
7	8-1/2	1	1-5/8	2-3/4	2-3/4	1-1/8	3	2-1/2	6.58	3	2-1/2	1-1/2	1-1/8	1-1/4	1-13/16	1	1-7/8	3

**Table 2** The dimensions given on this table are affected by the piston rod diameter and the stroke.

• = For piston rod dimensions see page 60.

BORE DIA.	ROD MM•	A	P	W	Y	LB	SE	WF	XC	XD	XE	ZC	ZD	ZE
1-1/2	5/8	3/4	2-3/4	5/8	2-1/16	4-5/8	6-3/4	1	6-3/8	6-3/4	6-1/2	6-7/8	7-1/4	6-7/8
	1	1-1/8	2-3/4	1	2-7/16	4-5/8	6-3/4	1-3/8	6-3/4	7-1/8	6-7/8	7-1/4	7-5/8	7-1/4
2	1	1-1/8	2-3/4	3/4	2-7/16	4-5/8	7-1/8	1-3/8	7-1/4	7-7/8	6-15/16	8	8-5/8	7-7/16
	1-3/8	1-5/8	2-3/4	1	2-11/16	4-5/8	7-1/8	1-5/8	7-1/2	8-1/8	7-3/16	8-1/4	8-7/8	7-11/16
2-1/2	1	1-1/8	2-7/8	3/4	2-7/16	4-3/4	7-1/4	1-3/8	7-3/8	8	7-1/16	8-1/8	8-3/4	7-9/16
	1-3/8	1-5/8	2-7/8	1	2-11/16	4-3/4	7-1/4	1-5/8	7-5/8	8-1/4	7-5/16	8-3/8	9	7-13/16
	1-3/4	2	2-7/8	1-1/4	2-15/16	4-3/4	7-1/4	1-7/8	7-7/8	8-1/2	7-9/16	8-5/8	9-1/4	8-1/16
3-1/4	1-3/8	1-5/8	3-1/4	7/8	3	5-1/2	8-1/2	1-5/8	8-5/8	9-1/2	8-1/4	9-5/8	10-1/2	8-7/8
	1-3/4	2	3-1/4	1-1/8	3-1/4	5-1/2	8-1/2	1-7/8	8-7/8	9-3/4	8-1/2	9-7/8	10-3/4	9-1/8
	2	2-1/4	3-1/4	1-1/4	3-3/8	5-1/2	8-1/2	2	9	9-7/8	8-5/8	10	10-7/8	9-1/4
4	1-3/4	2	3-1/2	1	3-1/4	5-3/4	8-7/8	1-7/8	9-3/4	10-5/8	8-3/4	11-1/8	12	9-3/8
	2	2-1/4	3-1/2	1-1/8	3-3/8	5-3/4	8-7/8	2	9-7/8	10-3/4	8-7/8	11-1/4	12-1/8	9-1/2
	2-1/2	3	3-1/2	1-3/8	3-5/8	5-3/4	8-7/8	2-1/4	10-1/8	11	9-1/8	11-1/2	12-3/8	9-3/4
5	2	2-1/4	4	1-1/8	3-3/8	6-1/4	10-1/8	2	10-1/2	11-5/8	9-3/4	12-1/4	13-3/8	10-1/2
	2-1/2	3	4	1-3/8	3-5/8	6-1/4	10-1/8	2-1/4	10-3/4	11-7/8	10	12-1/2	13-5/8	10-3/4
	3	3-1/2	4	1-3/8	3-5/8	6-1/4	10-1/8	2-1/4	10-3/4	11-7/8	10	12-1/2	13-5/8	10-3/4
	3-1/2	3-1/2	4	1-3/8	3-5/8	6-1/4	10-1/8	2-1/4	10-3/4	11-7/8	10	12-1/2	13-5/8	10-3/4
6	2-1/2	3	4-5/8	1-1/4	3-3/4	7-3/8	11-3/4	2-1/4	12-1/8	13-9/16	11-5/16	14-1/8	15-9/16	12-1/2
	3	3-1/2	4-5/8	1-1/4	3-3/4	7-3/8	11-3/4	2-1/4	12-1/8	13-9/16	11-5/16	14-1/8	15-9/16	12-1/2
	3-1/2	3-1/2	4-5/8	1-1/4	3-3/4	7-3/8	11-3/4	2-1/4	12-1/8	13-9/16	11-5/16	14-1/8	15-9/16	12-1/2
	4	4	4-5/8	1-1/4	3-3/4	7-3/8	11-3/4	2-1/4	12-1/8	13-9/16	11-5/16	14-1/8	15-9/16	12-1/2
7	3	3-1/2	5-3/8	1-1/4	3-13/16	8-1/2	13-1/8	2-1/4	13-3/4	15-3/8	12-9/16	16-1/4	17-7/8	13-9/16
	3-1/2	3-1/2	5-3/8	1-1/4	3-13/16	8-1/2	13-1/8	2-1/4	13-3/4	15-3/8	12-9/16	16-1/4	17-7/8	13-9/16
	4	4	5-3/8	1-1/4	3-13/16	8-1/2	13-1/8	2-1/4	13-3/4	15-3/8	12-9/16	16-1/4	17-7/8	13-9/16
	4-1/2	4-1/2	5-3/8	1-1/4	3-13/16	8-1/2	13-1/8	2-1/4	13-3/4	15-3/8	12-9/16	16-1/4	17-7/8	13-9/16
	5	5	5-3/8	1-1/4	3-13/16	8-1/2	13-1/8	2-1/4	13-3/4	15-3/8	12-9/16	16-1/4	17-7/8	13-9/16

**MODEL AL (NFPA STD. MS7) 8" DIAMETER BORE**

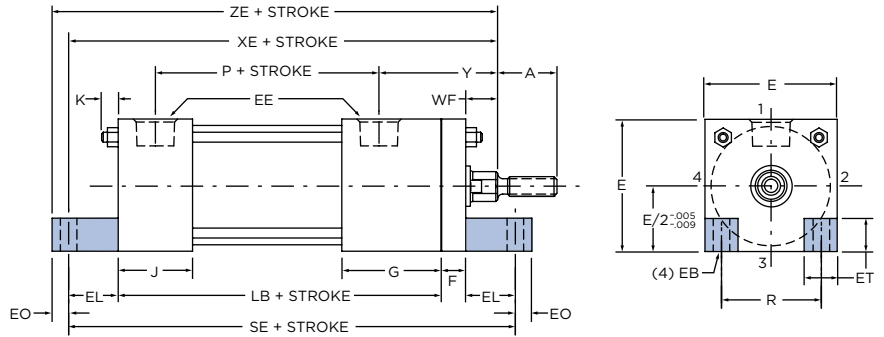
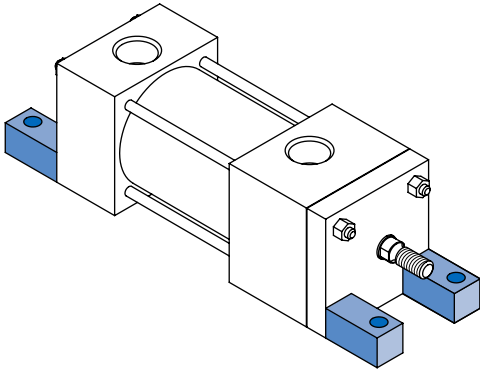

**MODEL E (NFPA STD. MP1) 8" THROUGH 20" DIAMETER BORE**

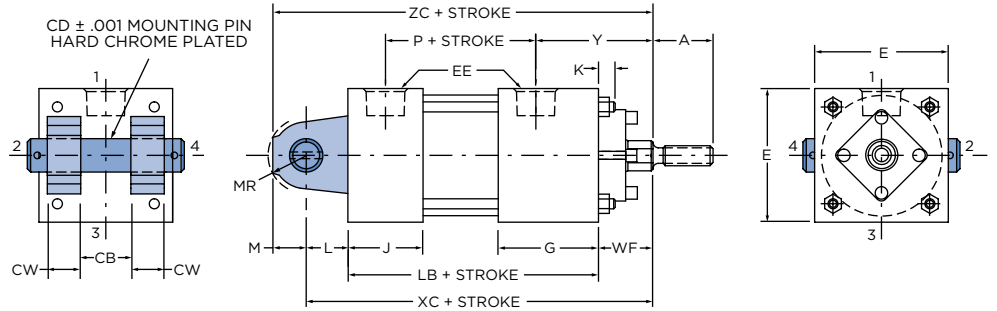
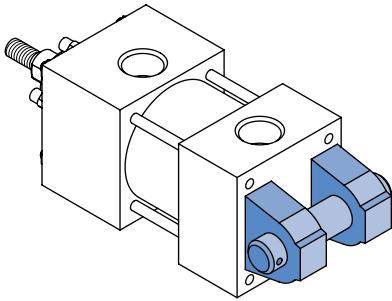

**NOTE:** Pin  $\varnothing$  is CD. Swing radius is MR.

**MODEL HE (NFPA STD. MP2) 8" DIAMETER BORE**

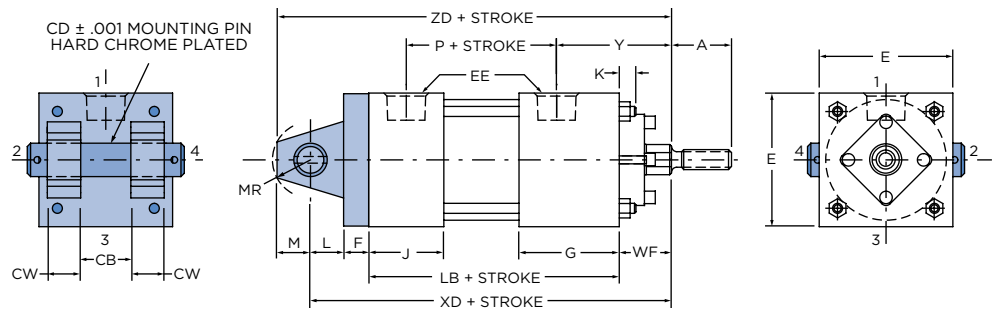
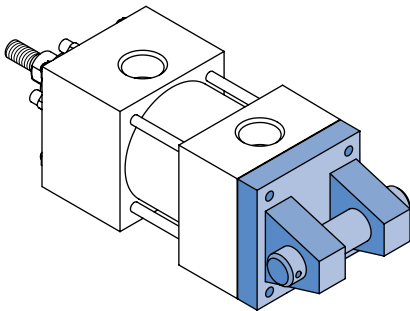

**NOTE:** Pin  $\varnothing$  is CD. Swing radius is MR.

# END LUG AND CLEVIS MOUNT CYLINDERS

8" THROUGH 20" DIAMETER

**Table 1** These dimensions are constant regardless of rod diameter or stroke.

For double rod end cylinders Model AL: subtract dimension J from G and add to dimension SE + stroke.  
Double rod end models are designated by letter "X" preceding the model identification. See page 56.

• = Dimensions refer to bolt diameter.

BORE DIA.	E	F		G	J	K	L	M	R	CB	CD	CW	EB•	EE	EL	EO	ET	MR
		AL	HE															
8	9-1/2	1	2	3	3	1-3/8	3-1/4	2-3/4	7.50	3	3	1-1/2	1-1/4	1-1/2	2	1-1/8	2	3-1/4
10	12-5/8	-	-	3-11/16	3-11/16	1-1/8	4	3-1/2	-	4	3-1/2	2	-	2	-	-	-	3-1/2
12	14-7/8	-	-	4-7/16	4-7/16	1-1/8	4-5/8	4	-	4-1/2	4	2-1/4	-	2-1/2	-	-	-	4
14	17-1/4	-	-	4-7/8	4-7/8	1-7/16	5-5/8	5	-	6	5	3	-	2-1/2	-	-	-	5
16	19-1/4	-	-	5-7/8	5-7/8	1-7/16	7	6	-	7	6	3-1/2	-	3	-	-	-	6
18	22	-	-	6-7/8	6-7/8	1-7/16	7-5/8	6-1/2	-	8	6-1/2	4	-	3	-	-	-	6-1/2
20	23-5/8	-	-	7-7/8	7-7/8	1-7/16	8-3/4	7-1/2	-	9	7-1/2	4-1/2	-	3	-	-	-	7-1/2

**Table 2** The dimensions given on this table are affected by the piston rod diameter and the stroke.

• = For piston rod dimensions see page 60.

BORE DIA.	ROD MM•	A	P	W	Y	LB	SE	WF	XC	XD	XE	ZC	ZD	ZE
8	3-1/2	3-1/2	6	1-1/4	4	9-1/2	14-1/2	2-1/4	15	17	13-3/4	17-3/4	19-3/4	14-7/8
	4	4	6	1-1/4	4	9-1/2	14-1/2	2-1/4	15	17	13-3/4	17-3/4	19-3/4	14-7/8
	4-1/2	4-1/2	6	1-1/4	4	9-1/2	14-1/2	2-1/4	15	17	13-3/4	17-3/4	19-3/4	14-7/8
	5	5	6	1-1/4	4	9-1/2	14-1/2	2-1/4	15	17	13-3/4	17-3/4	19-3/4	14-7/8
	5-1/2	5-1/2	6	1-1/4	4	9-1/2	14-1/2	2-1/4	15	17	13-3/4	17-3/4	19-3/4	14-7/8
10	4-1/2	4-1/2	8	-	5	12-1/8	-	2-15/16	19-1/16	-	-	22-9/16	-	-
	5	5	8	-	5-1/4	12-1/8	-	3-3/16	19-5/16	-	-	22-13/16	-	-
	5-1/2	5-1/2	8	-	5-1/4	12-1/8	-	3-3/16	19-5/16	-	-	22-13/16	-	-
	7	7	8	-	5-1/4	12-1/8	-	3-3/16	19-5/16	-	-	22-13/16	-	-
12	5-1/2	5-1/2	9-5/8	-	5-5/8	14-1/2	-	3-3/16	22-5/16	-	-	26-5/16	-	-
	7	7	9-5/8	-	5-7/8	14-1/2	-	3-7/16	22-9/16	-	-	26-9/16	-	-
	8	8	9-5/8	-	5-7/8	14-1/2	-	3-7/16	22-9/16	-	-	26-9/16	-	-
14	7	7	9-7/8	-	6-3/8	15-5/8	-	3-1/2	24-3/4	-	-	29-3/4	-	-
	8	8	9-7/8	-	6-3/8	15-5/8	-	3-1/2	24-3/4	-	-	29-3/4	-	-
	10	10	9-7/8	-	6-3/8	15-5/8	-	3-1/2	24-3/4	-	-	29-3/4	-	-
16	8	8	11-3/8	-	7-3/8	18-1/8	-	4	29-1/8	-	-	35-1/8	-	-
	9	9	11-3/8	-	7-3/8	18-1/8	-	4	29-1/8	-	-	35-1/8	-	-
	10	10	11-3/8	-	7-3/8	18-1/8	-	4	29-1/8	-	-	35-1/8	-	-
18	9	9	12-3/8	-	8-5/8	21-1/8	-	4-1/4	33	-	-	39-1/2	-	-
	10	10	12-3/8	-	8-5/8	21-1/8	-	4-1/4	33	-	-	39-1/2	-	-
20	10	10	13-3/8	-	9-5/8	23-5/8	-	4-1/2	36-7/8	-	-	44-3/8	-	-

**MODEL E3 (NFPA STD. MP3)**

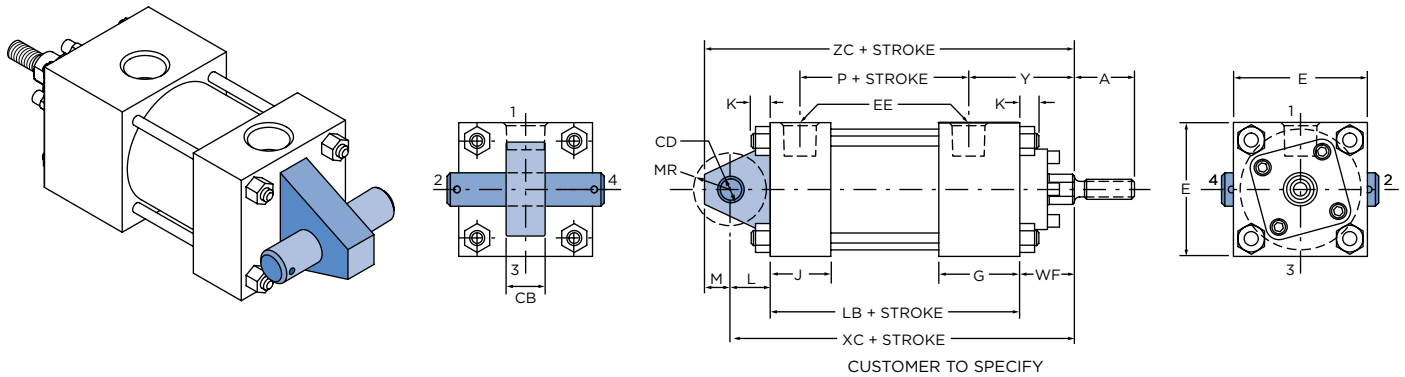

**Table 1** These dimensions are constant regardless of rod diameter or stroke.

BORE DIA.	E	F	G	J	K	L	M	CB	CD	EE	MR
1-1/2	2-1/2	3/8	1-3/4	1-1/2	1/2	3/4	1/2	3/4	1/2	1/2	5/8
2	3	5/8	1-3/4	1-1/2	1/2	1-1/4	3/4	1-1/4	3/4	1/2	7/8
2-1/2	3-1/2	5/8	1-3/4	1-1/2	5/8	1-1/4	3/4	1-1/4	3/4	1/2	7/8
3-1/4	4-1/2	3/4	2-1/4	1-3/4	3/4	1-1/2	1	1-1/2	1	3/4	1-1/4
4	5	7/8	2-1/4	1-3/4	3/4	2-1/8	1-3/8	2	1-3/8	3/4	1-5/8
5	6-1/2	7/8	2-1/4	1-3/4	1	2-1/4	1-3/4	2-1/2	1-3/4	3/4	2
6	7-1/2	1	2-1/2	2-1/4	1-1/8	2-1/2	2	2-1/2	2	1	2-3/8
7	8-1/2	1	2-3/4	2-3/4	1-1/8	3	2-1/2	3	2-1/2	1-1/4	3
8	9-1/2	1	3	3	1-3/8	3-1/4	2-3/4	3	3	1-1/2	3-1/4
10	12-5/8	-	3-11/16	3-11/16	1-1/8	4	3-1/2	4	3-1/2	2	3-1/2
12	14-7/8	-	4-7/16	4-7/16	1-1/8	4-5/8	4	4-1/2	4	2-1/2	4
14	17-1/4	-	4-7/8	4-7/8	1-1/8	5-5/8	5	6	5	2-1/2	5
16	19-1/4	-	5-7/8	5-7/8	1-7/16	7	6	7	6	3	6
18	22	-	6-7/8	6-7/8	1-7/16	7-5/8	6-1/2	8	6-1/2	3	6-1/2
20	23-5/8	-	7-7/8	7-7/8	1-7/16	8-3/4	7-1/2	9	7-1/2	3	7-1/2

# FIXED EYE MOUNT CYLINDERS

1-1/2" THROUGH 20" DIAMETER

**Table 2** The dimensions given on this table are affected by the piston rod diameter and the stroke.

• = For piston rod dimensions see page 60.

BORE DIA.	ROD MM•	A	P	W	Y	LB	WF	XC	ZC
1-1/2	5/8	3/4	2-3/4	5/8	2-1/16	4-5/8	1	6-3/8	6-7/8
	1	1-1/8	2-3/4	1	2-7/16	1-3/8	6-3/4	7-1/4	8
2	1	1-1/8	2-3/4	3/4	2-7/16	4-5/8	1-3/8	7-1/4	8
	1-3/8	1-5/8	2-3/4	1	2-1/16	4-5/8	1-5/8	7-1/2	8-1/4
2-1/2	1	1-1/8	2-7/8	3/4	2-7/16	4-3/4	1-3/8	7-3/8	8-1/8
	1-3/8	1-5/8	2-7/8	1	2-1/16	4-3/4	1-5/8	7-5/8	8-3/8
	1-3/4	2	2-7/8	1-1/4	2-15/16	4-3/4	1-7/8	7-7/8	8-5/8
3-1/4	1-3/8	1-5/8	3-1/4	7/8	3	5-1/2	1-5/8	8-5/8	9-5/8
	1-3/4	2	3-1/4	1-1/8	3-1/4	5-1/2	1-7/8	8-7/8	9-7/8
	2	2-1/4	3-1/4	1-1/4	3-3/8	5-1/2	2	9	10
4	1-3/4	2	3-1/2	1	3-1/4	5-3/4	1-7/8	9-3/4	11-1/8
	2	2-1/4	3-1/2	1-1/8	3-3/8	5-3/4	2	9-7/8	11-1/4
	2-1/2	3	3-1/2	1-3/8	3-5/8	5-3/4	2-1/4	10-1/8	11-1/2
5	2	2-1/4	4	1-1/8	3-3/8	6-1/4	2	10-1/2	12-1/4
	2-1/2	3	4	1-3/8	3-5/8	6-1/4	2-1/4	10-3/4	12-1/2
	3	3-1/2	4	1-3/8	3-5/8	6-1/4	2-1/4	10-3/4	12-1/2
	3-1/2	3-1/2	4	1-3/8	3-5/8	6-1/4	2-1/4	10-3/4	12-1/2
6	2-1/2	3	4-5/8	1-1/4	3-3/4	7-3/8	2-1/4	12-1/8	14-1/8
	3	3-1/2	4-5/8	1-1/4	3-3/4	7-3/8	2-1/4	12-1/8	14-1/8
	3-1/2	3-1/2	4-5/8	1-1/4	3-3/4	7-3/8	2-1/4	12-1/8	14-1/8
	4	4	4-5/8	1-1/4	3-3/4	7-3/8	2-1/4	12-1/8	14-1/8
7	3	3-1/2	5-3/8	1-1/4	3-13/16	8-1/2	2-1/4	13-3/4	16-1/4
	3-1/2	3-1/2	5-3/8	1-1/4	3-13/16	8-1/2	2-1/4	13-3/4	16-1/4
	4	4	5-3/8	1-1/4	3-13/16	8-1/2	2-1/4	13-3/4	16-1/4
	4-1/2	4-1/2	5-3/8	1-1/4	3-13/16	8-1/2	2-1/4	13-3/4	16-1/4
	5	5	5-3/8	1-1/4	3-13/16	8-1/2	2-1/4	13-3/4	16-1/4
8	3-1/2	3-1/2	6	1-1/4	4	9-1/2	2-1/4	15	17-3/4
	4	4	6	1-1/4	4	9-1/2	2-1/4	15	17-3/4
	4-1/2	4-1/2	6	1-1/4	4	9-1/2	2-1/4	15	17-3/4
	5	5	6	1-1/4	4	9-1/2	2-1/4	15	17-3/4
	5-1/2	5-1/2	6	1-1/4	4	9-1/2	2-1/4	15	17-3/4
10	4-1/2	4-1/2	8	-	5	12-1/8	2-15/16	19-1/16	22-9/16
	5	5	8	-	5-1/4	12-1/8	3-3/16	19-5/16	22-13/16
	5-1/2	5-1/2	8	-	5-1/4	12-1/8	3-3/16	19-5/16	22-13/16
	7	7	8	-	5-1/4	12-1/8	3-3/16	19-5/16	22-13/16
12	5-1/2	5-1/2	9-5/8	-	5-5/8	14-1/2	3-3/16	22-5/16	26-5/16
	7	7	9-5/8	-	5-7/8	14-1/2	3/7-16	22-9/16	26-9/16
	8	8	9-5/8	-	5-7/8	14-1/2	3/7-16	22-9/16	26-9/16
14	7	7	9-7/8	-	6-3/8	15-5/8	3-1/2	24-3/4	29-3/4
	8	8	9-7/8	-	6-3/8	15-5/8	3-1/2	24-3/4	29-3/4
	10	10	9-7/8	-	6-3/8	15-5/8	3-1/2	24-3/4	29-3/4
16	8	8	11-3/8	-	7-3/8	18-1/8	4	29-1/8	35-1/8
	9	9	11-3/8	-	7-3/8	18-1/8	4	29-1/8	35-1/8
	10	10	11-3/8	-	7-3/8	18-1/8	4	29-1/8	35-1/8
18	9	9	12-3/8	-	8-5/8	21-1/8	4-1/4	33	39-1/2
	10	10	12-3/8	-	8-5/8	21-1/8	4-1/4	33	39-1/2
20	10	10	13-3/8	-	9-5/8	23-5/8	4-1/2	36-7/8	44-3/8

**MODEL EU3 (NFPA STD. MPU3)**

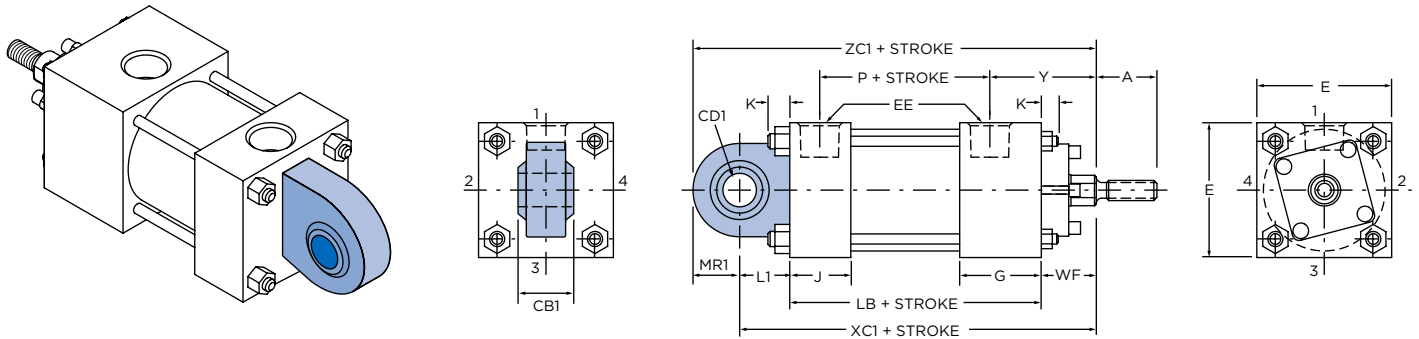

**Table 1** These dimensions are constant regardless of rod diameter or stroke.

BORE DIA.	E	G	J	K	EE	L1	CB1	CD1	MR1	PRESSURE RATING
1-1/2	2-1/2	1-3/4	1-1/2	1/2	1/2	3/4	7/16	1/2	7/8	1500 PSI
2	3	1-3/4	1-1/2	1/2	1/2	1-1/4	21/32	3/4	1-1/4	2000 PSI
2-1/2	3-1/2	1-3/4	1-1/2	5/8	1/2	1-1/4	21/32	3/4	1-1/4	1400 PSI
3-1/4	4-1/2	2-1/4	1-3/4	3/4	3/4	1-1/2	7/8	1	1-1/2	1400 PSI
4	5	2-1/4	1-3/4	3/4	3/4	2-1/8	1-3/16	1-3/8	1-3/4	1600 PSI
5	6 1/2	2-1/4	1-3/4	1	3/4	2-1/4	1-17/32	1-3/4	2-1/4	1800 PSI
6	7 1/2	2-1/2	2-1/4	1-1/8	1	2-1/2	1-3/4	2	2-3/4	1700 PSI

# SPHERICAL EYE MOUNT CYLINDERS

1-1/2" THROUGH 6" DIAMETER

**Table 2** The dimensions given on this table are affected by the piston rod diameter and the stroke.

• = For piston rod dimensions see page 60.

BORE DIA.	ROD MM•	A	P	Y	LB	WF	XC1	ZC1
1-1/2	5/8	3/4	2-3/4	2-1/16	4-5/8	1	6-3/8	7-1/4
	1	1-1/8	2-3/4	2-7/16	4-5/8	1-3/8	6-3/4	7-5/8
2	1	1-1/8	2-3/4	2-7/16	4-5/8	1-3/8	7-1/4	8-1/2
	1-3/8	1-5/8	2-3/4	2-11/16	4-5/8	1-5/8	7-1/2	8-3/4
2-1/2	1	1-1/8	2-7/8	2-7/16	4-3/4	1-3/8	7-3/8	8-5/8
	1-3/8	1-5/8	2-7/8	2-11/16	4-3/4	1-5/8	7-5/8	8-7/8
	1-3/4	2	2-7/8	2-15/16	4-3/4	1-7/8	7-7/8	9-1/8
3-1/4	1-3/8	1-5/8	3-1/4	3	5-1/2	1-5/8	8-5/8	10-1/8
	1-3/4	2	3-1/4	3-1/4	5-1/2	1-7/8	8-7/8	10-3/8
	2	2-1/4	3-1/4	3-3/8	5-1/2	2	9	10-1/2
4	1-3/4	2	3-1/2	3-1/4	5-3/4	1-7/8	9-3/4	11-1/2
	2	2-1/4	3-1/2	3-3/8	5-3/4	2	9-7/8	11-5/8
	2-1/2	3	3-1/2	3-5/8	5-3/4	2-1/4	10-1/8	11-7/8
5	2	2-1/4	4	3-3/8	6-1/4	2	10-1/2	12-3/4
	2-1/2	3	4	3-5/8	6-1/4	2-1/4	10-3/4	13
	3	3-1/2	4	3.375	6-1/4	2-1/4	10-3/4	13
	3-1/2	3-1/2	4	3.375	6-1/4	2-1/4	10-3/4	13
6	2-1/2	3	4-5/8	3-3/4	7-3/8	2-1/4	12-1/8	14-7/8
	3	3-1/2	4-5/8	3.4375	7-3/8	2-1/4	12-1/8	14-7/8
	3-1/2	3-1/2	4-5/8	3.4375	7-3/8	2-1/4	12-1/8	14-7/8
	4	4	4-5/8	3.4375	7-3/8	2-1/4	12-1/8	14-7/8

**MODEL F (NFPA STD. MT4)▲**

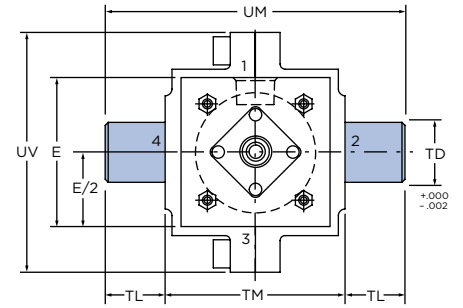
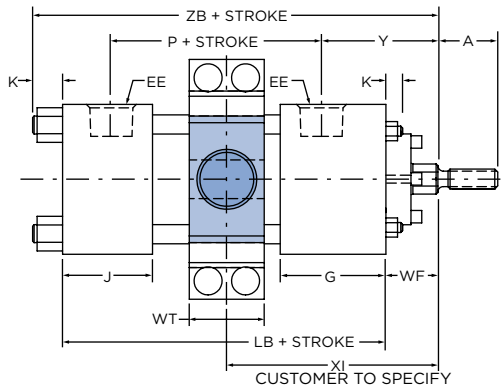
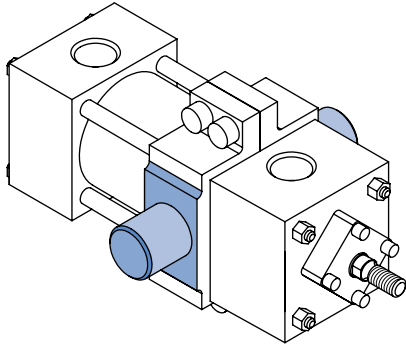

Integral trunnion pins are designed for shear, not bending, loads. The intermediate trunnion pin mounting location, being non-adjustable, is determined by the "XI" dimension which should be specified by the customer. It can be located at any point between the heads of the cylinder.

**MODEL FB (NFPA STD. MT2)▲**

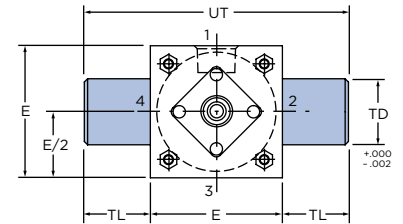
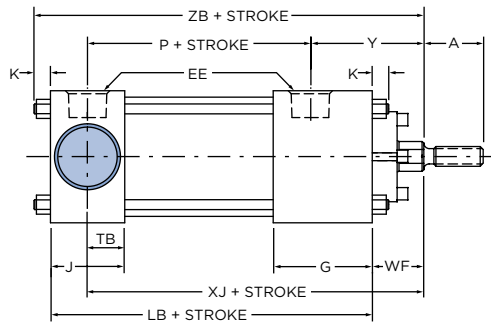
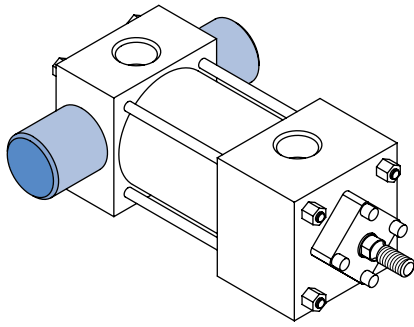

Integral trunnion pins are designed for shear, not bending, loads.

**MODEL FR (NFPA STD. MT1)▲**

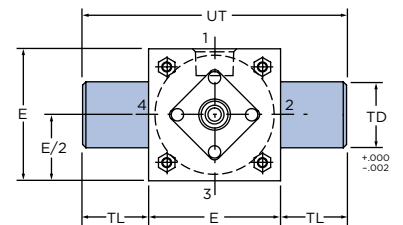
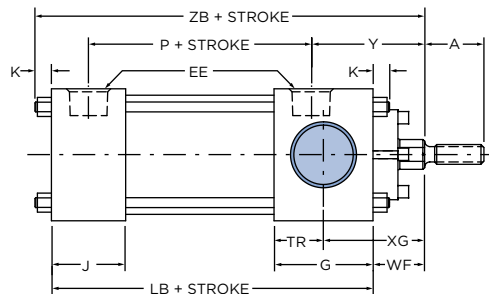
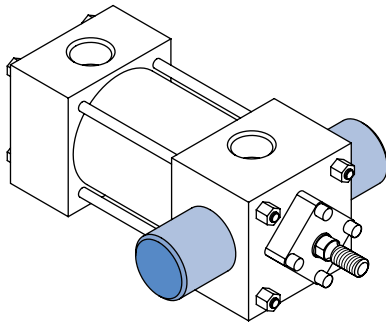

Integral trunnion pins are designed for shear, not bending, loads.

▲ = See Table A on page 57 for bore and rod combinations using head plates with threaded bronze glands.



# TRUNNION MOUNT CYLINDERS

1-1/2" THROUGH 7" DIAMETER

**Table 1** These dimensions are constant regardless of rod diameter or stroke.

Double rod end models are designated by letter "X" preceding the model identification. See page 56.

BORE DIA.	E	G	J	K	EE	TB	TD	TL	TM	TR	UM	UT	UV	WT
1-1/2	2-1/2	1-3/4	1-1/2	1/2	1/2	3/4	1	1	3	7/8	5	4-1/2	4	1-1/4
2	3	1-3/4	1-1/2	1/2	1/2	3/4	1-3/8	1-3/8	3-1/2	7/8	6-1/4	5-3/4	4-3/4	1-1/2
2-1/2	3-1/2	1-3/4	1-1/2	5/8	1/2	3/4	1-3/8	1-3/8	4	7/8	6-3/4	6-1/4	5-1/4	1-1/2
3-1/4	4-1/2	2-1/4	1-3/4	3/4	3/4	7/8	1-3/4	1-3/4	5	1-1/4	8-1/2	8	6-3/4	2
4	5	2-1/4	1-3/4	3/4	3/4	7/8	1-3/4	1-3/4	5-1/2	1-1/4	9	8-1/2	7-1/4	2
5	6-1/2	2-1/4	1-3/4	1	3/4	7/8	1-3/4	1-3/4	7	1-1/4	10-1/2	10	9	2
6	7-1/2	2-1/2	2-1/4	1-1/8	1	1	2	2	8	1-3/8	12	11-1/2	10-1/4	2-1/2
7	8-1/2	2-3/4	2-3/4	1-1/8	1-1/4	1-3/8	2-1/2	2-1/2	9	1-3/8	14	13-1/2	11-1/4	2-3/4

**Table 2** The dimensions given on this table are affected by the piston rod diameter and the stroke.

• = For piston rod dimensions see page 60.

BORE DIA.	ROD MM•	A	P	Y	LB	WF	XG	XI (MIN)	XJ	ZB
1-1/2	5/8	3/4	2-3/4	2-1/16	4-5/8	1	1-7/8	3-7/16	4-7/8	6-1/8
	1	1-1/8	2-3/4	2-7/16	4-5/8	1-3/8	2-1/4	3-13/16	5-1/4	6-1/2
2	1	1-1/8	2-3/4	2-7/16	4-5/8	1-3/8	2-1/4	3-15/16	5-1/4	6-1/2
	1-3/8	1-5/8	2-3/4	2-11/16	4-5/8	1-5/8	2-1/2	4-3/16	5-1/2	6-3/4
2-1/2	1	1-1/8	2-7/8	2-7/16	4-3/4	1-3/8	2-1/4	3-15/16	5-3/8	6-3/4
	1-3/8	1-5/8	2-7/8	2-11/16	4-3/4	1-5/8	2-1/2	4-3/16	5-5/8	7
	1-3/4	2	2-7/8	2-15/16	4-3/4	1-7/8	2-3/4	4-7/16	5-7/8	7-1/4
3-1/4	1-3/8	1-5/8	3-1/4	3	5-1/2	1-5/8	2-5/8	4-15/16	6-1/4	7-7/8
	1-3/4	2	3-1/4	3-1/4	5-1/2	1-7/8	2-7/8	5-3/16	6-1/2	8-1/8
	2	2-1/4	3-1/4	3-3/8	5-1/2	2	3	5-5/16	6-5/8	8-1/4
4	1-3/4	2	3-1/2	3-1/4	5-3/4	1-7/8	2-7/8	5-3/16	6-3/4	8-3/8
	2	2-1/4	3-1/2	3-3/8	5-3/4	2	3	5-5/16	6-7/8	8-1/2
	2-1/2	3	3-1/2	3-5/8	5-3/4	2-1/4	3-1/4	5-9/16	7-1/8	8-3/4
5	2	2-1/4	4	3-3/8	6-1/4	2	3	5-5/16	7-3/8	9-1/4
	2-1/2	3	4	3-5/8	6-1/4	2-1/4	3-1/4	5-9/16	7-5/8	9-1/2
	3	3-1/2	4	3-5/8	6-1/4	2-1/4	3-1/4	5-9/16	7-5/8	9-1/2
	3-1/2	3-1/2	4	3-5/8	6-1/4	2-1/4	3-1/4	5-9/16	7-5/8	9-1/2
6	2-1/2	3	4-5/8	3-3/4	7-3/8	2-1/4	3-3/8	6-1/16	8-3/8	10-3/4
	3	3-1/2	4-5/8	3-3/4	7-3/8	2-1/4	3-3/8	6-1/16	8-3/8	10-3/4
	3-1/2	3-1/2	4-5/8	3-3/4	7-3/8	2-1/4	3-3/8	6-1/16	8-3/8	10-3/4
	4	4	4-5/8	3-3/4	7-3/8	2-1/4	3-3/8	6-1/16	8-3/8	10-3/4
7	3	3-1/2	5-3/8	3-13/16	8-1/2	2-1/4	3-5/8	6-7/16	8-3/8	11-7/8
	3-1/2	3-1/2	5-3/8	3-13/16	8-1/2	2-1/4	3-5/8	6-7/16	9-3/8	11-7/8
	4	4	5-3/8	3-13/16	8-1/2	2-1/4	3-5/8	6-7/16	9-3/8	11-7/8
	4-1/2	4-1/2	5-3/8	3-13/16	8-1/2	2-1/4	3-5/8	6-7/16	9-3/8	11-7/8
	5	5	5-3/8	3-13/16	8-1/2	2-1/4	3-5/8	6-7/16	9-3/8	11-7/8

**MODEL F (NFPA STD. MT4)**

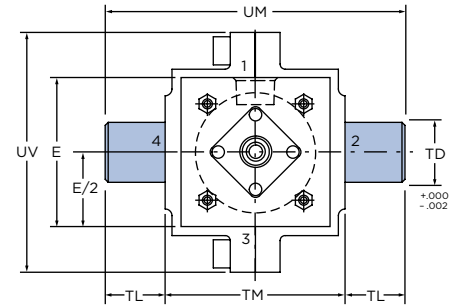
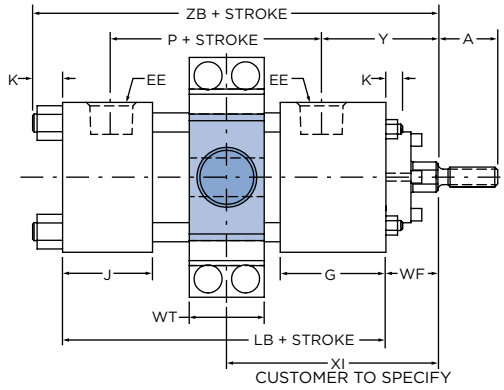
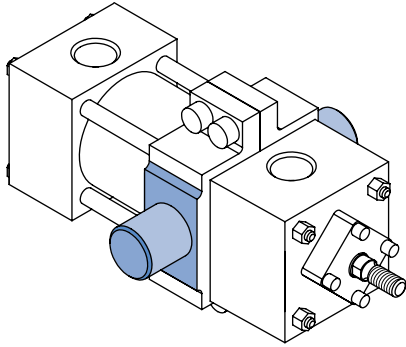

Integral trunnion pins are designed for shear, not bending, loads. The intermediate trunnion pin mounting location, being non-adjustable, is determined by the "XI" dimension which should be specified by the customer. It can be located at any point between the heads of the cylinder.

**MODEL FB (NFPA STD. MT2)**

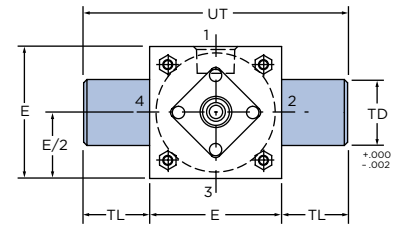
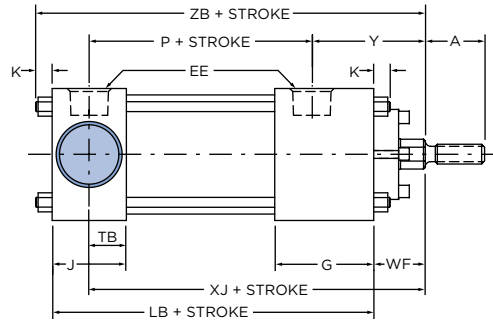
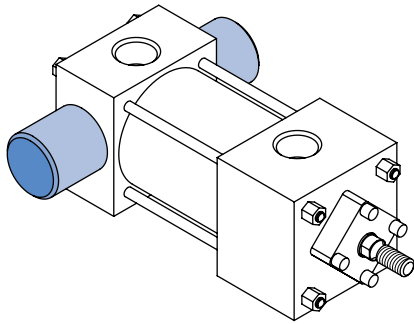

Integral trunnion pins are designed for shear, not bending, loads.

**MODEL FR (NFPA STD. MT1)**

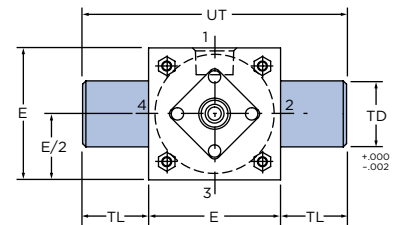
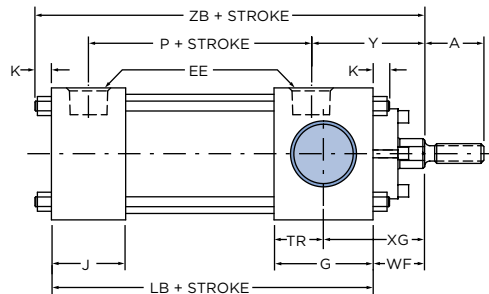
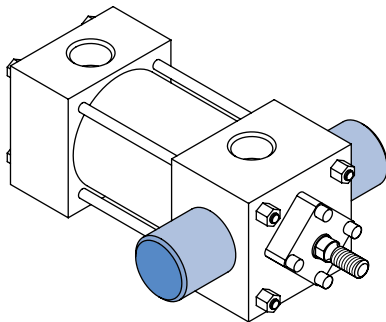

Integral trunnion pins are designed for shear, not bending, loads.

# TRUNNION MOUNT CYLINDERS

8" THROUGH 14" DIAMETER

**Table 1** These dimensions are constant regardless of rod diameter or stroke.

Double rod end models are designated by letter "X" preceding the model identification. See page 56.

BORE DIA.	E	G	J	K	EE	TB	TD	TL	TM	TR	UM	UT	UV	WT
8	9-1/2	3	3	1-3/8	1-1/2	1-1/2	3	3	10	1-1/2	16	15-1/2	12-1/2	3-1/4
10	12-5/8	3-11/16	3-11/16	1-1/8	2	1-7/8	3-1/2	3-1/2	14	1-7/8	21	19-5/8	16-1/2	4-1/2
12	14-7/8	4-7/16	4-7/16	1-1/8	2-1/2	2-1/4	4	4	16-1/2	2-1/4	24-1/2	22-7/8	19-1/4	5-1/2
14	17-1/4	4-7/8	4-7/8	1-7/16	2-1/2	2-7/16	4-1/2	4-1/2	19-5/8	2-1/2	28-5/8	26-1/8	22-1/2	5-1/2

**Table 2** The dimensions given on this table are affected by the piston rod diameter and the stroke.

• = For piston rod dimensions see page 60.

BORE DIA.	ROD MM•	A	P	Y	LB	WF	XG	XI (MIN)	XJ	ZB
8	3-1/2	3-1/2	6	4	9-1/2	2-1/4	3-3/4	6-15/16	10-1/4	13-1/8
	4	4	6	4	9-1/2	2-1/4	3-3/4	6-15/16	10-1/4	13-1/8
	4-1/2	4-1/2	6	4	9-1/2	2-1/4	3-3/4	6-15/16	10-1/4	13-1/8
	5	5	6	4	9-1/2	2-1/4	3-3/4	6-15/16	10-1/4	13-1/8
	5-1/2	5-1/2	6	4	9-1/2	2-1/4	3-3/4	6-15/16	10-1/4	13-1/8
10	4-1/2	4-1/2	8	5	12-1/8	2-15/16	4-3/4	8-7/8	13-1/4	16-3/16
	5	5	8	5-1/4	12-1/8	3-3/16	5	9-1/8	13-1/2	16-7/16
	5-1/2	5-1/2	8	5-1/4	12-1/8	3-3/16	5	9-1/8	13-1/2	16-7/16
	7	7	8	5-1/4	12-1/8	3-3/16	5	9-1/8	13-1/2	16-7/16
12	5-1/2	5-1/2	9-5/8	5-5/8	14-1/2	3-3/16	5-3/8	10-3/8	15-1/2	18-3/16
	7	7	9-5/8	5-7/8	14-1/2	3-7/16	5-5/8	10-5/8	15-3/4	19-1/16
	8	8	9-5/8	5-7/8	14-1/2	3-7/16	5-5/8	10-5/8	15-3/4	19-1/16
14	7	7	9-7/8	6-3/8	15-5/8	3-1/2	5-7/8	11-1/8	16-3/4	20-1/4
	8	8	9-7/8	6-3/8	15-5/8	3-1/2	5-7/8	11-1/8	16-3/4	20-1/4
	10	10	9-7/8	6-3/8	15-5/8	3-1/2	5-7/8	11-1/8	16-3/4	20-1/4

**MODEL T (NFPA STD. MX1)**

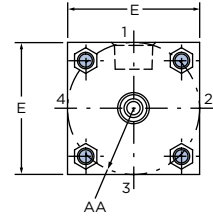
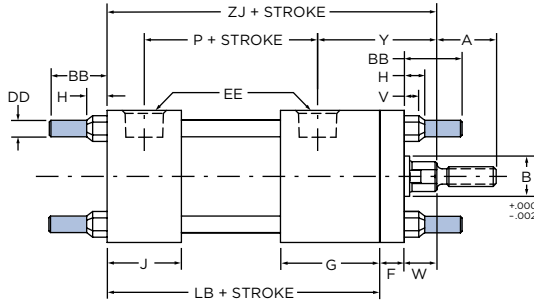
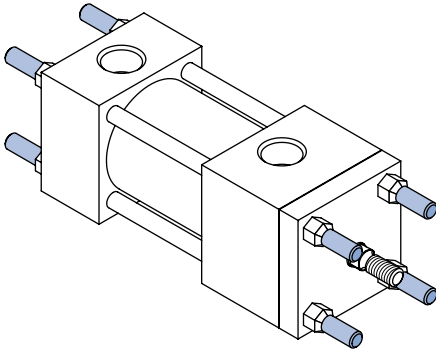

**MODEL TB (NFPA STD. MX2) ▲**

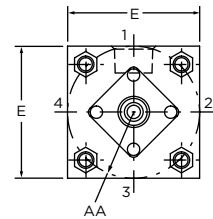
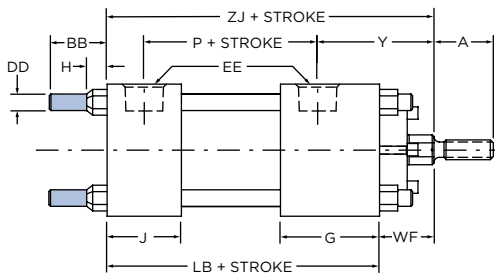
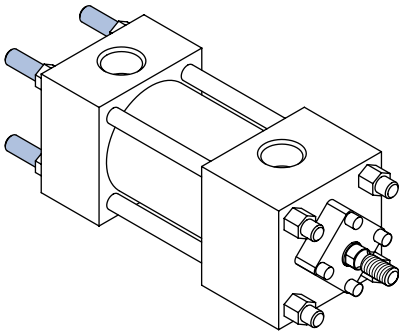

**MODEL TR (NFPA STD. MX3)**

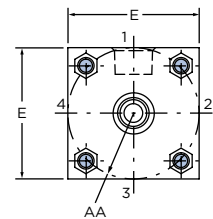
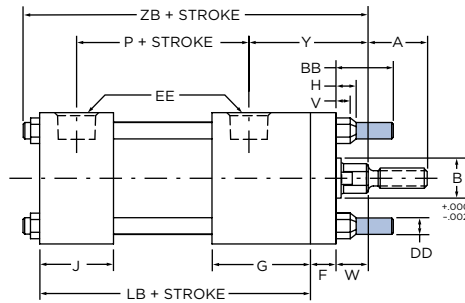
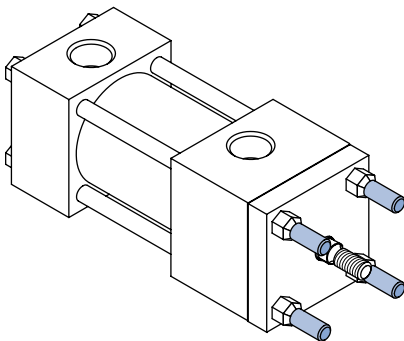

▲ = See Table A on page 57 for bore and rod combinations using head plates with threaded bronze glands.

# TIE-ROD MOUNT CYLINDERS

1-1/2" THROUGH 8" DIAMETER

**Table 1** These dimensions are constant regardless of rod diameter or stroke.

Double rod end models are designated by letter "X" preceding the model identification. See page 56.

BORE DIA.	E	F	G	H	J	AA	BB	DD	EE
1-1/2	2-1/2	3/8	1-3/4	11/32	1-1/2	2.56	1-3/8	3/8-24	1/2
2	3	5/8	1-3/4	3/8	1-1/2	3.10	1-5/8	7/16-20	1/2
2-1/2	3-1/2	5/8	1-3/4	15/32	1-1/2	3.61	1-7/8	1/2-20	1/2
3-1/4	4-1/2	3/4	2-1/4	9/16	1-3/4	4.60	2-3/8	5/8-18	3/4
4	5	7/8	2-1/4	9/16	1-3/4	5.40	2-3/8	5/8-18	3/4
5	6-1/2	7/8	2-1/4	25/32	1-3/4	7.00	3-1/4	7/8-14	3/4
6	7-1/2	1	2-1/2	7/8	2-1/4	8.10	3-5/8	1-14	1
7	8-1/2	1	2-3/4	1	2-3/4	9.30	4-1/8	1-1/8-12	1-1/4
8	9-1/2	1	3	1-1/8	3	10.61	4-1/2	1-1/4-12	1-1/2

**Table 2** The dimensions given on this table are affected by the piston rod diameter and the stroke.

• = For piston rod dimensions see page 60.

BORE DIA.	ROD MM•	A	B	P	V	W	Y	LB	WF	ZB	ZJ
1-1/2	5/8	3/4	1-1/8	2-3/4	1/4	5/8	2-1/16	4-5/8	1	6-1/8	5-5/8
	1	1-1/8	1-1/2	2-3/4	1/2	1	2-7/16	4-5/8	1-3/8	6-1/2	6
2	1	1-1/8	1-1/2	2-3/4	1/4	3/4	2-7/16	4-5/8	1-3/8	6-1/2	6
	1-3/8	1-5/8	2	2-3/4	3/8	1	2-11/16	4-5/8	1-5/8	6-3/4	6-1/4
2-1/2	1	1-1/8	1-1/2	2-7/8	1/4	3/4	2-7/16	4-3/4	1-3/8	6-3/4	6-1/8
	1-3/8	1-5/8	2	2-7/8	3/8	1	2-11/16	4-3/4	1-5/8	7	6-3/8
	1-3/4	2	2-3/8	2-7/8	1/2	1-1/4	2-15/16	4-3/4	1-7/8	7-1/4	6-5/8
3-1/4	1-3/8	1-5/8	2	3-1/4	1/4	7/8	3	5-1/2	1-5/8	7-7/8	7-1/8
	1-3/4	2	2-3/8	3-1/4	3/8	1-1/8	3-1/4	5-1/2	1-7/8	8-1/8	7-3/8
	2	2-1/4	2-5/8	3-1/4	3/8	1-1/4	3-3/8	5-1/2	2	8-1/4	7-1/2
4	1-3/4	2	2-3/8	3-1/2	1/4	1	3-1/4	5-3/4	1-7/8	8-3/8	7-5/8
	2	2-1/4	2-5/8	3-1/2	1/4	1-1/8	3-3/8	5-3/4	2	8-1/2	7-3/4
	2-1/2	3	3-1/8	3-1/2	3/8	1-3/8	3-5/8	5-3/4	2-1/4	8-3/4	8
5	2	2-1/4	2-5/8	4	1/4	1-1/8	3-3/8	6-1/4	2	9-1/4	8-1/4
	2-1/2	3	3-1/8	4	3/8	1-3/8	3-5/8	6-1/4	2-1/4	9-1/2	8-1/2
	3	3-1/2	3-3/4	4	3/8	1-3/8	3-5/8	6-1/4	2-1/4	9-1/2	8-1/2
	3-1/2	3-1/2	4-1/4	4	3/8	1-3/8	3-5/8	6-1/4	2-1/4	9-1/2	8-1/2
6	2-1/2	3	3-1/8	4-5/8	1/4	1-1/4	3-3/4	7-3/8	2-1/4	10-3/4	9-5/8
	3	3-1/2	3-3/4	4-5/8	1/4	1-1/4	3-3/4	7-3/8	2-1/4	10-3/4	9-5/8
	3-1/2	3-1/2	4-1/4	4-5/8	1/4	1-1/4	3-3/4	7-3/8	2-1/4	10-3/4	9-5/8
	4	4	4-3/4	4-5/8	1/4	1-1/4	3-3/4	7-3/8	2-1/4	10-3/4	9-5/8
7	3	3-1/2	3-3/4	5-3/8	1/4	1-1/4	3-13/16	8-1/2	2-1/4	11-7/8	10-3/4
	3-1/2	3-1/2	4-1/4	5-3/8	1/4	1-1/4	3-13/16	8-1/2	2-1/4	11-7/8	10-3/4
	4	4	4-3/4	5-3/8	1/4	1-1/4	3-13/16	8-1/2	2-1/4	11-7/8	10-3/4
	4-1/2	4-1/2	5-1/4	5-3/8	1/4	1-1/4	3-13/16	8-1/2	2-1/4	11-7/8	10-3/4
	5	5	5-3/4	5-3/8	1/4	1-1/4	3-13/16	8-1/2	2-1/4	11-7/8	10-3/4
8	3-1/2	3-1/2	4-1/4	6	1/4	1-1/4	4	9-1/2	2-1/4	13-1/8	11-3/4
	4	4	4-3/4	6	1/4	1-1/4	4	9-1/2	2-1/4	13-1/8	11-3/4
	4-1/2	4-1/2	5-1/4	6	1/4	1-1/4	4	9-1/2	2-1/4	13-1/8	11-3/4
	5	5	5-3/4	6	1/4	1-1/4	4	9-1/2	2-1/4	13-1/8	11-3/4
	5-1/2	5-1/2	6-1/4	6	1/4	1-1/4	4	9-1/2	2-1/4	13-1/8	11-3/4

**MODEL T (NFPA STD. MX1)**

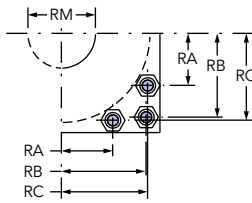
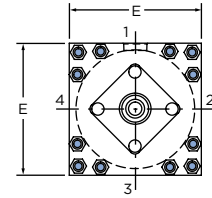
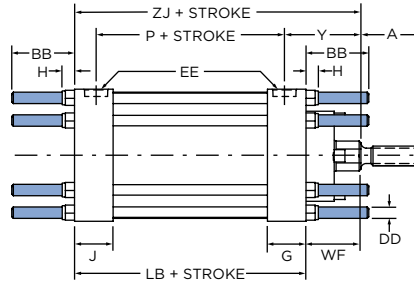
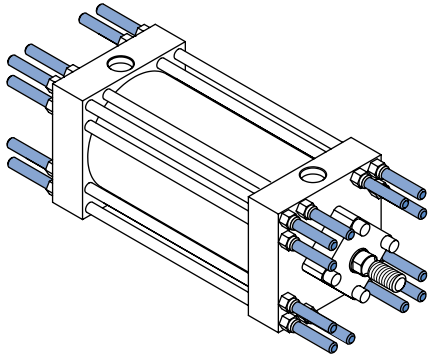

**10" Bore**

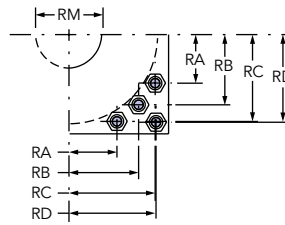

**12" Bore**

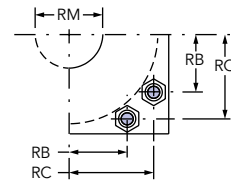

**14" Bore**

**MODEL TB (NFPA STD. MX2)**

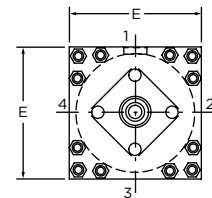
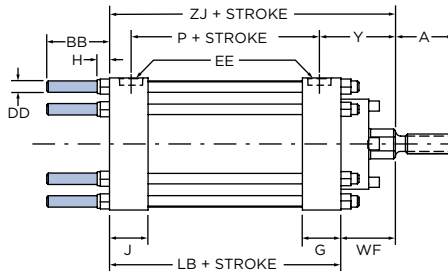
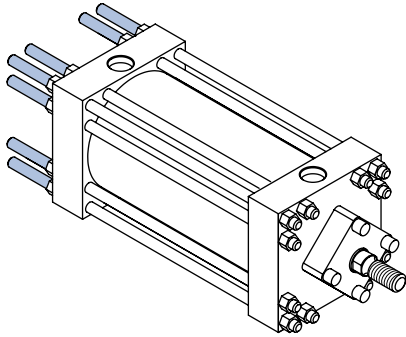

**MODEL TR (NFPA STD. MX3)**

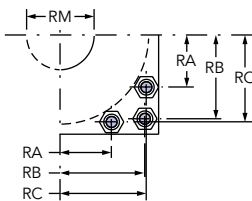
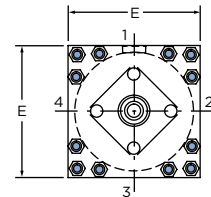
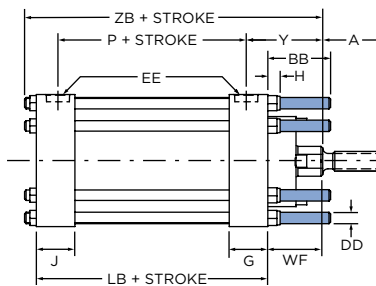
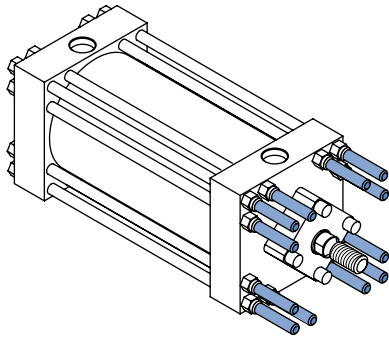

**10" Bore**

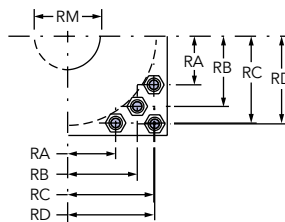

**12" Bore**

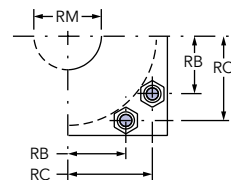

**14" Bore**

# TIE-ROD MOUNT CYLINDERS

10" THROUGH 14" DIAMETER

**Table 1** These dimensions are constant regardless of rod diameter or stroke.

Double rod end models are designated by letter "X" preceding the model identification. See page 56.

BORE DIA.	E	G	H	J	BB	DD	EE	RA	RB	RC	RD	RE
10	12-5/8	3-11/16	7/8	3-11/16	6	1-14	2	3.312	5.438	5.531	-	-
12	14-7/8	4-7/16	7/8	4-7/16	7	1-14	2-1/2	3.718	5.344	6.593	6.656	-
14	17-1/4	4-7/8	1-9/32	4-7/8	8	1-1/2-12	2-1/2	-	5	7.313	-	-

**Table 2** The dimensions given on this table are affected by the piston rod diameter and the stroke.

• = For piston rod dimensions see page 60.

BORE DIA.	ROD MM•	A	P	Y	LB	RM	WF	ZB	ZJ
10	4-1/2	4-1/2	8	5	12-1/8	7-3/4	2-15/16	16-3/16	15-1/16
	5	5	8	5-1/4	12-1/8	8-3/8	3-3/16	16-7/16	15-5/16
	5-1/2	5-1/2	8	5-1/4	12-1/8	9	3-3/16	16-7/16	15-5/16
	7	7	8	5-1/4	12-1/8	10-1/4	3-3/16	16-7/16	15-5/16
12	5-1/2	5-1/2	9-5/8	5-5/8	14-1/2	9	3-3/16	18-13/16	17-11/16
	7	7	9-5/8	5-7/8	14-1/2	10-1/4	3-7/16	19-1/16	17-15/16
	8	8	9-5/8	5-7/8	14-1/2	11-1/4	3-7/16	19-1/16	17-15/16
14	7	7	9-7/8	6-3/8	15-5/8	10-1/4	3-1/2	20-1/4	19-1/8
	8	8	9-7/8	6-3/8	15-5/8	11-1/4	3-1/2	20-1/4	19-1/8
	10	10	9-7/8	6-3/8	15-5/8	14	3-1/2	20-1/4	19-1/8

**MODEL H (BASIC CYLINDER NO MOUNT)** ▲

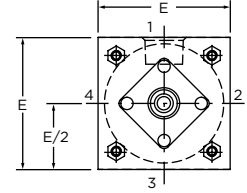
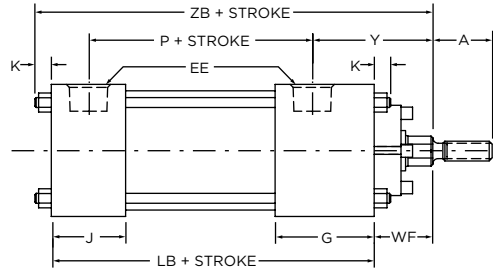
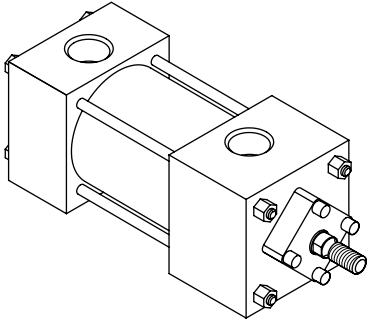

**MODEL XH (BASIC CYLINDER DOUBLE ROD END)** ▲

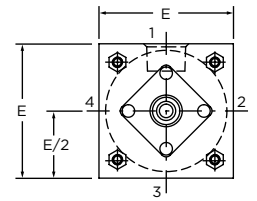
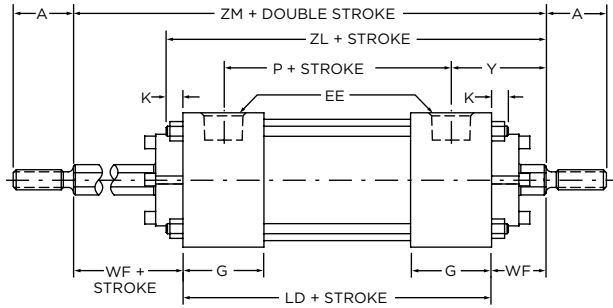
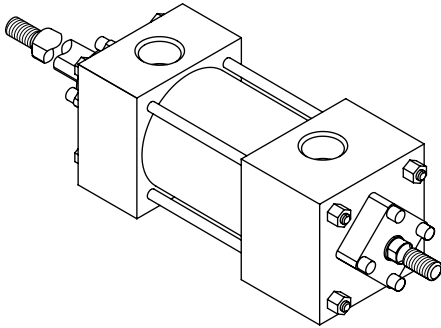

▲ = See Table A on page 57 for bore and rod combinations using head plates with threaded bronze glands.



# BASIC MODEL NO MOUNT AND DOUBLE ROD END CYLINDERS

1-1/2" THROUGH 6" DIAMETER

**Table 1** These dimensions are constant regardless of rod diameter or stroke.

BORE DIA.	E	F	G	J	K
1-1/2	2-1/2	3/8	1-3/4	1-1/2	1/2
2	3	5/8	1-3/4	1-1/2	1/2
2-1/2	3-1/2	5/8	1-3/4	1-1/2	5/8
3-1/4	4-1/2	3/4	2-1/4	1-3/4	3/4
4	5	7/8	2-1/4	1-3/4	3/4
5	6-1/2	7/8	2-1/4	1-3/4	1
6	7-1/2	1	2-1/2	2-1/4	1-1/8

**Table 2** The dimensions given on this table are affected by the piston rod diameter and the stroke.

• = For piston rod dimensions see page 60.

BORE DIA.	ROD MM•	A	P	Y	LB	LD	W	WF	ZB	ZL	ZM
1-1/2	5/8	3/4	2-3/4	2-1/16	4-5/8	4-7/8	5/8	1	6-1/8	6-3/8	6-7/8
	1	1-1/8	2-3/4	2-7/16	4-5/8	4-7/8	1	1-3/8	6-1/2	6-3/4	7-5/8
2	1	1-1/8	2-3/4	2-7/16	4-5/8	4-7/8	3/4	1-3/8	6-1/2	6-3/4	7-5/8
	1-3/8	1-5/8	2-3/4	2-11/16	4-5/8	4-7/8	1	1-5/8	6-3/4	7	8-1/8
2-1/2	1	1-1/8	2-7/8	2-7/16	4-3/4	5	3/4	1-3/8	6-3/4	7	7-3/4
	1-3/8	1-5/8	2-7/8	2-11/16	4-3/4	5	1	1-5/8	7	7-1/4	8-1/4
	1-3/4	2	2-7/8	2-15/16	4-3/4	5	1-1/4	1-7/8	7-1/4	7-1/2	8-3/4
3-1/4	1-3/8	1-5/8	3-1/4	3	5-1/2	6	7/8	1-5/8	7-7/8	8-3/8	9-1/4
	1-3/4	2	3-1/4	3-1/4	5-1/2	6	1-1/8	1-7/8	8-1/8	8-5/8	9-3/4
	2	2-1/4	3-1/4	3-3/8	5-1/2	6	1-1/4	2	8-1/4	8-3/4	10
4	1-3/4	2	3-1/2	3-1/4	5-3/4	6-1/4	1	1-7/8	8-3/8	8-7/8	10
	2	2-1/4	3-1/2	3-3/8	5-3/4	6-1/4	1-1/8	2	8-1/2	9	10-1/4
	2-1/2	3	3-1/2	3-5/8	5-3/4	6-1/4	1-3/8	2-1/4	8-3/4	9-1/4	10-3/4
5	2	2-1/4	4	3-3/8	6-1/4	6-3/4	1-1/8	2	9-1/4	9-3/4	10-3/4
	2-1/2	3	4	3-5/8	6-1/4	6-3/4	1-3/8	2-1/4	9-1/2	10	11-1/4
	3	3-1/2	4	3-5/8	6-1/4	6-3/4	1-3/8	2-1/4	9-1/2	10	11-1/4
	3-1/2	3-1/2	4	3-5/8	6-1/4	6-3/4	1-3/8	2-1/4	9-1/2	10	11-1/4
6	2-1/2	3	4-5/8	3-3/4	7-3/8	7-5/8	1-1/4	2-1/4	10-3/4	11	12-1/8
	3	3-1/2	4-5/8	3-3/4	7-3/8	7-5/8	1-1/4	2-1/4	10-3/4	11	12-1/8
	3-1/2	3-1/2	4-5/8	3-3/4	7-3/8	7-5/8	1-1/4	2-1/4	10-3/4	11	12-1/8
	4	4	4-5/8	3-3/4	7-3/8	7-5/8	1-1/4	2-1/4	10-3/4	11	12-1/8

**NOTE:** Cylinder mountings, rod sizes and thread types are interchangeable on either end of double rod end cylinder assembly.

**Table A**

THE FOLLOWING BORE/ROD COMBINATIONS USE HEAD PLATE AND BRONZE GLANDS AS SHOWN AT RIGHT	
BORE	ROD DIAMETER (MM)
1-1/2	1.00"
2	1.38"
2-1/2	1.75"

**NOTE:** Threaded Bronze Gland used on all Model D and DD Cylinders.  
Bolt-on Gland used on all Model G & DG Cylinders.

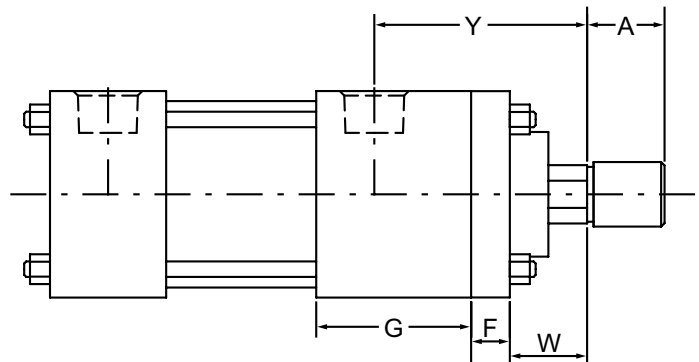

**MODEL H (BASIC CYLINDER NO MOUNT)**

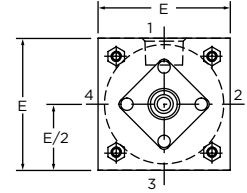
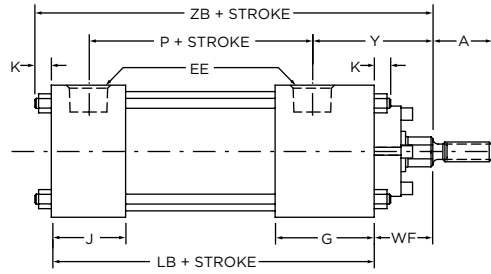
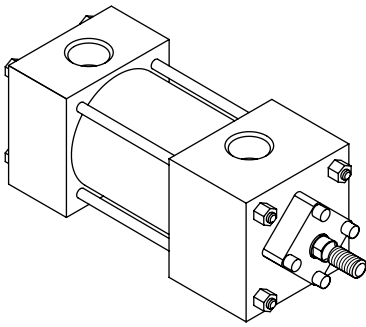

**MODEL XH (BASIC CYLINDER DOUBLE ROD END)**

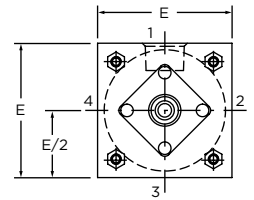
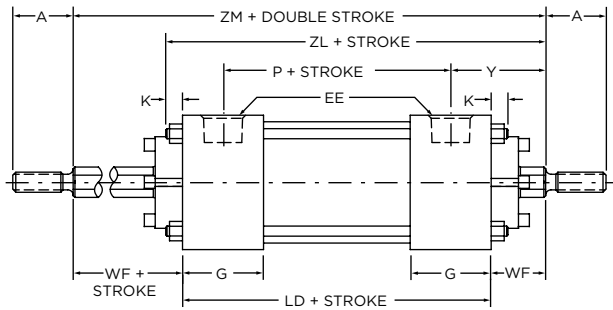
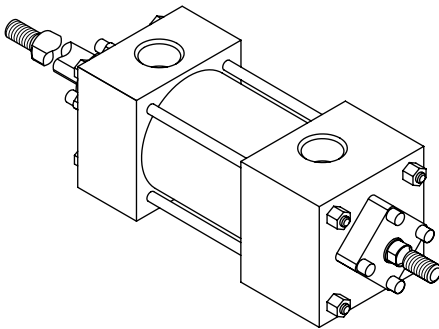

# BASIC MODEL NO MOUNT AND DOUBLE ROD END CYLINDERS

7" THROUGH 20" DIAMETER

**Table 1** These dimensions are constant regardless of rod diameter or stroke.

BORE DIA.	E	G	J	K	EE
7	8-1/2	2-3/4	2-3/4	1-1/8	1-1/4
8	9-1/2	3	3	1-3/8	1-1/2
10	12-5/8	3-11/16	3-11/16	1-1/8	2
12	14-7/8	4-7/16	4-7/16	1-1/8	2-1/2
14	17-1/4	4-7/8	4-7/8	1-1/4	2-1/2
16	19-1/4	5-7/8	5-7/8	1-7/16	3
18	22	6-7/8	6-7/8	1-7/16	3
20	23-5/8	7-7/8	7-7/8	1-7/16	3

**Table 2** The dimensions given on this table are affected by the piston rod diameter and the stroke.

• = For piston rod dimensions see page 60.

BORE DIA.	ROD MM•	A	P	Y	LB	LD	WF	ZB	ZL	ZM
7	3	3-1/2	5-3/8	3-13/16	8-1/2	8-1/2	2-1/4	11-7/8	11-7/8	13
	3-1/2	3-1/2	5-3/8	3-13/16	8-1/2	8-1/2	2-1/4	11-7/8	11-7/8	13
	4	4	5-3/8	3-13/16	8-1/2	8-1/2	2-1/4	11-7/8	11-7/8	13
	4-1/2	4-1/2	5-3/8	3-13/16	8-1/2	8-1/2	2-1/4	11-7/8	11-7/8	13
	5	5	5-3/8	3-13/16	8-1/2	8-1/2	2-1/4	11-7/8	11-7/8	13
8	3-1/2	3-1/2	6	4	9-1/2	9-1/2	2-1/4	13-1/8	13-1/8	14
	4	4	6	4	9-1/2	9-1/2	2-1/4	13-1/8	13-1/8	14
	4-1/2	4-1/2	6	4	9-1/2	9-1/2	2-1/4	13-1/8	13-1/8	14
	5	5	6	4	9-1/2	9-1/2	2-1/4	13-1/8	13-1/8	14
	5-1/2	5-1/2	6	4	9-1/2	9-1/2	2-1/4	13-1/8	13-1/8	14
10	4-1/2	4-1/2	8	5	12-1/8	12-1/8	2-15/16	16-3/16	16-3/16	18
	5	5	8	5-1/4	12-1/8	12-1/8	3-3/16	16-7/16	16-7/16	18-1/2
	5-1/2	5-1/2	8	5-1/4	12-1/8	12-1/8	3-3/16	16-7/16	16-7/16	18-1/2
	7	7	8	5-1/4	12-1/8	12-1/8	3-3/16	16-7/16	16-7/16	18-1/2
12	5-1/2	5-1/2	9-5/8	5-5/8	14-1/2	14-1/2	3-3/16	18-13/16	18-13/16	20-7/8
	7	7	9-5/8	5-7/8	14-1/2	14-1/2	3-7/16	19-1/16	19-1/16	21-3/8
	8	8	9-5/8	5-7/8	14-1/2	14-1/2	3-7/16	19-1/16	19-1/16	21-3/8
14	7	7	9-7/8	6-3/8	15-5/8	15-5/8	3-1/2	20-1/4	20-1/4	22-5/8
	8	8	9-7/8	6-3/8	15-5/8	15-5/8	3-1/2	20-1/4	20-1/4	22-5/8
	10	10	9-7/8	6-3/8	15-5/8	15-5/8	3-1/2	20-1/4	20-1/4	22-5/8
16	8	8	11-3/8	7-3/8	18-1/8	18-1/8	4	23-9/16	23-9/16	26-1/8
	9	9	11-3/8	7-3/8	18-1/8	18-1/8	4	23-9/16	23-9/16	26-1/8
	10	10	11-3/8	7-3/8	18-1/8	18-1/8	4	23-9/16	23-9/16	26-1/8
18	9	9	12-3/8	8-5/8	21-1/8	21-1/8	4-1/4	26-13/16	26-13/16	29-5/8
	10	10	12-3/8	8-5/8	21-1/8	21-1/8	4-1/4	26-13/16	26-13/16	29-5/8
20	10	10	13-3/8	9-5/8	23-5/8	23-5/8	4-1/2	29-9/16	29-9/16	32-5/8

**NOTE:** Cylinder mountings, rod sizes and thread types are interchangeable on either end of double rod end cylinder assembly.

**CLASS 3 CYLINDER PISTON ROD END DIMENSIONAL DATA**

**ROD END TYPE NO. 1**

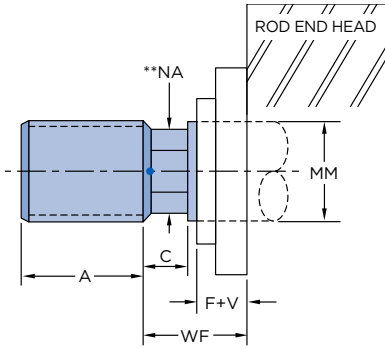

**ROD END TYPE NO. 3 & NO. 4\***

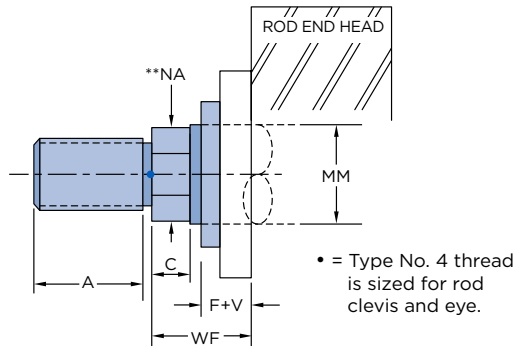

**ROD END TYPE NO. 5**

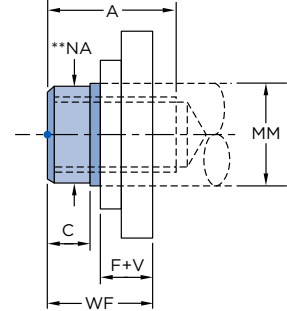

\*\* = Dimension NA is .060 under MM diameter dimension.

DIA. ROD MM	ROD END TYPE				A	C	D#	F+V	WF
	NO. 1	NO. 3	NO. 4*	NO. 5					
5/8	5/8-18	1/2-20	7/16-20	7/16-20	3/4	3/8	1/2	5/8	See the respective charts covering model (mount), bore, and rod diameter
1	1-14	7/8-14	3/4-16	3/4-16	1-1/8	1/2	7/8	3/4	
1-3/8	1-3/8-12	1-1/4-12	1-14	1-14	1-5/8	5/8	1-1/8	1	
1-3/4	1-3/4-12	1-1/2-12	1-1/4-12	1-1/4-12	2	3/4	1-1/2	3/4	
2	2-12	1-3/4-12	1-1/2-12	1-1/2-12	2-1/4	7/8	1-11/16	7/8	
2-1/2	2-1/2-12	2-1/4-12	1-7/8-12	1-7/8-12	3	1	2-1/16	1-1/16	
3	3-12	2-3/4-12	2-1/4-12	2-1/4-12	3-1/2	1	2-5/8	1-1/8	
3-1/2	3-1/2-12	3-1/4-12	2-1/2-12	2-1/2-12	3-1/2	1	3	1-1/8	
4	4-12	3-3/4-12	3-12	3-12	4	1	3-3/8	1-1/4	
4-1/2	4-1/2-12	4-1/4-12	3-1/4-12	3-1/4-12	4-1/2	1	3-7/8	1-1/4	
5	5-12	4-3/4-12	3-1/2-12	3-1/2-12	5	1	4-1/4	1-1/4	
5-1/2	5-1/2-12	5-1/4-12	4-12	4-12	5-1/2	1	4-5/8	1-1/4	
7	7-12	6-1/2-12	5-1/2-12	5-1/2-12	7	1	-	2-3/8	
8	8-12	7-1/2-12	5-3/4-12	5-3/4-12	8	1	-	2-3/8	
9	9-12	8-1/2-12	6-1/2-12	6-1/2-12	9	1	-	2-1/2	
10	10-12	9-1/2-12	7-1/4-12	7-1/4-12	10	1	-	2-1/2	

\* = Type 4 thread sized for clevis and rod eye accessories.

# = Dimension D is size across wrench flats.

**ROD END TYPE NO. 6**

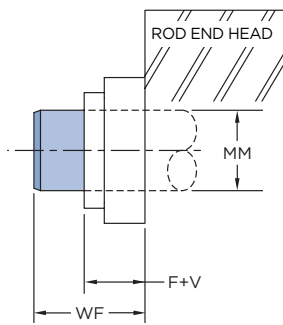

DIA. ROD MM	F+V	WF
5/8	5/8	1
1	3/4	1-3/8
1-3/8	1	1-5/8
1-3/4	3/4	1-7/8
2	7/8	2
2-1/2	1-1/16	2-1/4
3	1-1/8	2-1/4
3-1/2	1-1/8	2-1/4
4	1-1/4	2-1/4
4-1/2	1-1/4	2-1/4
5	1-1/4	2-1/4
5-1/2	1-1/4	2-1/4

**ROD END TYPE NO. 7**

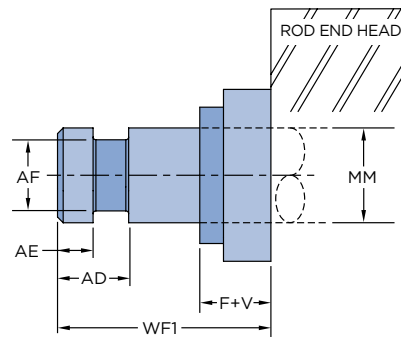

DIA. ROD MM	F+V	WF1	AD	AE	AF
5/8	5/8	1-3/4	5/8	1/4	3/8
1	3/4	2-1/2	15/16	3/8	11/16
1-3/8	1	2-3/4	1-1/16	3/8	7/8
1-3/4	3/4	3-1/8	1-5/16	1/2	1-1/8
2	7/8	3-3/4	1-11/16	5/8	1-3/8
2-1/2	1-1/16	4-1/2	1-15/16	3/4	1-3/4
3	1-1/8	4-7/8	2-7/16	7/8	2-1/4
3-1/2	1-1/8	5-5/8	2-11/16	1	2-1/2
4	1-1/4	5-3/4	2-11/16	1	3
4-1/2	1-1/4	6-1/2	3-3/16	1-1/2	3-1/2
5	1-1/4	6-5/8	3-3/16	1-1/2	3-7/8
5-1/2	1-1/4	7-1/2	3-15/16	1-7/8	4-3/8

## EYE BRACKET

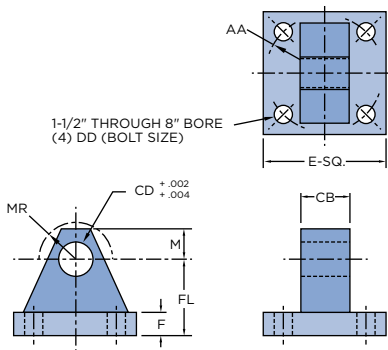

CYL. DIA.	E	F	M	AA	CB	CD	DD	FL	MR	PART NO.
1-1/2	2-1/2	3/8	1/2	2.30	3/4	1/2	3/8	1-1/8	5/8	2716 L47
2 - 2-1/2	3-1/2	5/8	3/4	3.61	1-1/4	3/4	1/2	1-7/8	7/8	2719 L32
3-1/4	4-1/2	7/8	1	4.60	1-1/2	1	5/8	2-3/8	1-1/4	2720 L33
4	5	7/8	1-3/8	5.40	2	1-3/8	5/8	3	1-5/8	2721 L34
5	6-1/2	1-1/8	1-3/4	7.00	2-1/2	1-3/4	7/8	3-3/8	2	2722 L35
6	7-1/2	1-7/16	2	8.10	2-1/2	2	1	3-15/16	2-3/8	2723 L36
7	8-1/2	1-5/8	2-1/2	9.30	3	2-1/2	1-1/8	4-5/8	3	2724 L37
8	9-1/2	2	2-3/4	10.61	3	3	1-1/4	5-1/4	3-1/4	2725 L38
10	12-5/8	2-3/8	3-1/2	•	4	3-1/2	1	6-3/8	3-1/2	2726 L39
12	14-7/8	2-7/8	4	•	4-1/2	4	1	7-1/2	4	2727 L40
14	17-1/4	3-3/8	5	•	6	5	1	9	5	2728 L41

For clevis bracket reference see models on page 40 and page 42.

• = See page 54 for bolt hole location.

## MOUNTING BRACKET

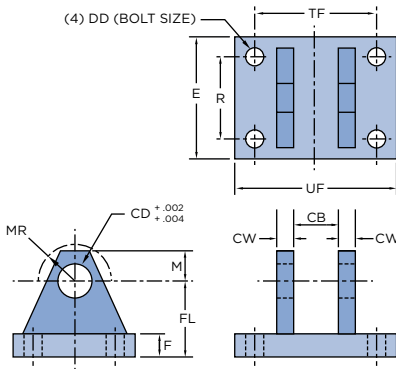

CYL. DIA.	E	F	M	R	CB	CD	CW	DD	FL	MR	TF	UF	PART NO.
1-1/2	2-1/2	3/8	1/2	1.63	3/4	1/2	1/2	3/8	1-1/8	5/8	2-3/4	3-1/2	2683 L47
2 - 2-1/2	3-1/2	5/8	3/4	2.55	1-1/4	3/4	5/8	1/2	1-7/8	7/8	3-3/4	4-3/4	2684 L47
3-1/4	4-1/2	7/8	1	3.25	1-1/2	1	3/4	5/8	2-3/8	1-1/4	4-1/2	5-3/4	2685 L47
4	5	7/8	1-3/8	3.82	2	1-3/8	1	5/8	3	1-5/8	5-1/2	6-3/4	2686 L47
5	6-1/2	1-1/8	1-3/4	4.95	2-1/2	1-3/4	1-1/4	7/8	3-3/8	2	7	8-1/2	2687 L47
6	7-1/2	1-7/16	2	5.73	2-1/2	2	1-1/4	1	3-15/16	2-3/8	7-1/2	9-1/4	2688 L47
7	8-1/2	1-5/8	2-1/2	6.58	3	2-1/2	1-1/2	1-1/8	4-5/8	3	8-1/2	10-1/2	2689 L47
8	9-1/2	2	2-3/4	7.50	3	3	1-1/2	1-1/4	5-1/4	3-1/4	8-3/4	10-3/4	2690 L47
10	12-5/8	2-3/8	3-1/2	9.62	4-1/8	3-1/2	2	1-3/4	6-3/8	3-1/2	12	15	2691 L47
12	14-7/8	2-7/8	4	11.45	4-5/8	4	2-1/4	2	7-1/2	4	14	18	2692 L47
14	17-1/4	3-3/8	5	13.36	6-1/8	5	3	2-1/4	9	5	17-3/4	22-1/2	2693 L47

## EYE (FEMALE)

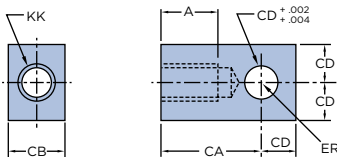

KK	A	CA	CB	CD	ER	PART NO.
7/16-20	3/4	1-1/2	3/4	1/2	5/8	1810 L59
3/4-16	1-1/8	2-1/16	1-1/4	3/4	1-1/16	1812 L59
1-14	1-5/8	2-13/16	1-1/2	1	1-7/16	1813 L59
1-1/4-12	2	3-7/16	2	1-3/8	2	1814 L59
1-1/2-12	2-1/4	4	2-1/2	1-3/4	2-1/16	1815 L59
1-7/8-12	3	5	2-1/2	2	2-1/4	1817 L59
2-1/4-12	3-1/2	5-13/16	3	2-1/2	2-7/8	1820 L59
2-1/2-12	3-1/2	6-1/8	3	3	3-1/8	1821 L59
3-1/4-12	4-1/2	7-5/8	4	3-1/2	3-7/8	1824 L59
4-12	5-1/2	9-1/8	4-1/2	4	4-7/16	1825 L59
5-1/2-12	7	11-7/8	6	5	5	1826 L59

## PIVOT - PIN

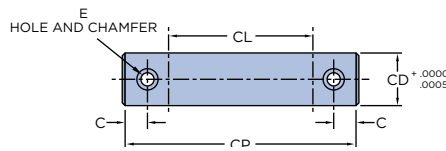

CYL. DIA.	C	E	CD	CP	CL	PART NO.
1-1/2	3/16	1/8	1/2	2-3/8	1.8	3222 L47-1
2 - 2-1/2	1/4	3/16	3/4	3-1/4	2.6	3222 L47-2
3-1/4	1/4	3/16	1	3-3/4	3.1	3222 L47-3
4	1/4	3/16	1-3/8	4-7/8	4.1	3222 L47-4
5	1/4	3/16	1-3/4	5-7/8	5.1	3222 L47-5
6	5/16	1/4	2	6-1/8	5.2	3222 L47-6
7	5/16	1/4	2-1/2	7-1/8	6.3	3222 L47-8
8	5/16	1/4	3	7-1/8	6.3	3222 L47-7
10	3/8	1/4	3-1/2	9-1/4	8.0	3222 L47-9
12	3/8	1/4	4	10-1/4	9.0	3222 L47-10
14	3/8	1/4	5	13-1/2	12.3	3222 L47-11

## CLEVIS (FEMALE)

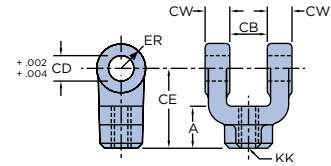

KK	A	CB	CD	CE	CW	ER	PART NO.
7/16-20	3/4	3/4	1/2	1-1/2	1/2	1/2	2834 L59
3/4-16	1-1/8	1-1/4	3/4	2-3/8	5/8	3/4	2835 L59
1-14	1-5/8	1-1/2	1	3-1/8	3/4	1	2836 L59
1-1/4-12	2	2	1-3/8	4-1/8	1	1-3/8	2837 L59
1-1/2-12	2-1/4	2-1/2	1-3/4	4-1/2	1-1/4	1-3/4	2838 L59
1-7/8-12	3	2-1/2	2	5-1/2	1-1/4	2	2839 L59
2-1/4-12	3-1/2	3	2-1/2	6-1/2	1-1/2	2-1/2	2840 L59
2-1/2-12	3-1/2	3	3	6-3/4	1-1/2	3	2841 L59
3-1/4-12	4-1/2	4	3-1/2	8-1/2	2	3-1/2	2842 L59
4-12	5-1/2	4-1/2	4	10	2-1/4	4	2843 L59
5-1/2-12	7	6	5	12-3/4	3	5	2844 L59

**SQUARE-HEAD CYLINDERS**

**NOPAK Cylinder with Switch (pictured)**

- Non-contact design
- Long life
- Pressures to 3000 PSI
- High reliability
- Versatile, easy operation

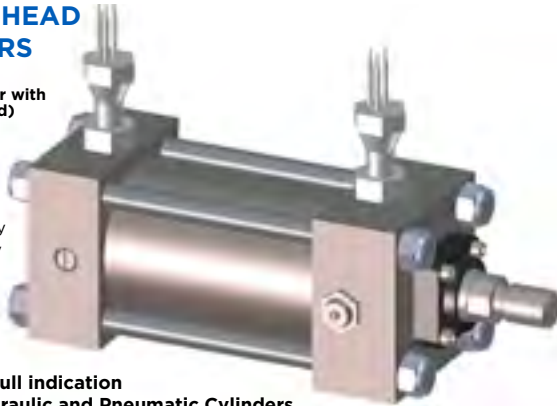

For positive full indication of stroke Hydraulic and Pneumatic Cylinders

**WORKING PRINCIPLE**

NOPAK Position Indicator Switches are easily mounted in both hydraulic and pneumatic cylinder heads to confirm the position of the piston in either extended or retracted positions. Designed for versatility, NOPAK switches can be mounted in virtually any position. When inserted in the cylinder head, the switch senses the cushion sleeve's position at end of stroke. NOPAK's threaded switch screws easily into the cylinder heads making it a natural for accurate confirmation. Totally self-contained, the switch will not be contaminated by dirt, oil, grease, and most corrosive atmospheres. The non-contact design also eliminates the need for linkage or external actuators. Heavy-duty construction allows the switch to withstand up to 3000 PSI of external pressure (higher pressure available upon request).

**DESIGN FEATURES**

- **Very Economical** - Easy to install, NOPAK Position Indicator Switches are totally self-contained, eliminating external power supply requirements.
- **Enclosure** - 300 Series Stainless Steel provides reliable performance under even the most adverse conditions.
- **Hermetically Sealed** - To ensure a clean, stable contact environment, the entire assembly is completely evacuated, then back-filled under pressure.
- **Long Life** - Tested to over 1,000,000 cycles. (Actual life varies with load.)
- **High Contact Pressure** - Heavy vibrations will not cause false operations of the switch. Good electrical characteristics for dry circuit and low load applications.

**SPECIFICATIONS**

**CONTACT ARRANGEMENT:**

Single Pole Double Throw SPDT (Form C)

**CONTACT RATINGS:**

UL Rated (NEMA Type 1)  
240 VAC @ 2A  
250 VDC @ 0.5A Resistive

Although not UL General Purpose, switch is suitable for:  
24 VDC @ 50 mA

**TEMPERATURE RANGE:**

-40°F (-40°C) to 221°F (105°C)

**RESPONSE TIME:** 8 milliseconds

**REPEATABILITY:**

0.002" (0.05 mm) of setpoint under identical operating conditions.

Consult Factory for other contact arrangements, ratings, terminations, and approvals.

**PROXIMITY POSITION INDICATOR SWITCH PRINCIPLES OF OPERATION**

The NOPAK Proximity Limit Switch is based on an operating principle which utilizes "new," high energy, rare earth magnets to provide an end sensing range fixed at approximately .072" (1.83 mm) with a ferrous actuator. Use of an external magnet increases this appreciably. The differential (hysteresis) is approximately half of the sensing range.

When time, accuracy, and dependability count... you can count on a NOPAK Indicator Switch. Maintenance free: engineered for precision, performance and reliability.

**NOTE:** This is not a 'reed' type switch.

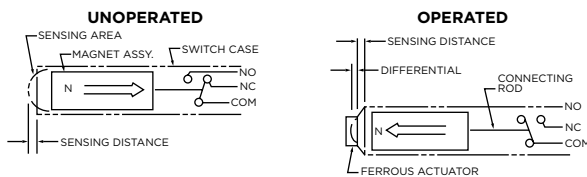

Wiring Color Code: Black = Common, Red = Normally Closed; Blue = Normally Open

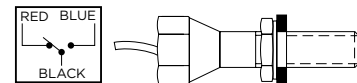

Switch enclosure incorporates a 1/2-14 NPT conduit connection. Switch wire connections are a potted 3 wire cable 18" long. External mounting threads are locked to cylinder head port with a hex jam nut and seal.

Where installation height is limited some switches are available with side-potted leads. Consult factory.

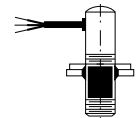

# NOPAK LINEAR DISPLACEMENT TRANSDUCER SYSTEM

NLDT SYSTEM SWITCH NUMBER

AVAILABLE IN:  
**CLASS 6**  
 (pictured)  
**CLASS 3**



## DESIGN AND PERFORMANCE FEATURES

- Non-contacting design - no wear, no friction, no noise and no adjustments.
- Completely solid state.
- Both analog and digital outputs are available.
- Quartz crystal time reference.
- Withstands corrosive environments and pressures up to 3000 PSI.
- Feedback sensor inside cylinder is protected from debris and mechanical damage.
- Absolute output, not incremental - no loss of position at restart.

**NOPAK** has a linear displacement transducer that is designed for use in air or hydraulic cylinder actuators. The transducer, available in lengths up to thirty feet, is threaded into the cylinder and sealed to withstand the pressures of hydraulic fluid. A permanent magnet is mounted on the piston end of the cylinder rod, and is used to determine the position of the piston inside the cylinder. Double ended rods not applicable.

**HERE'S HOW IT WORKS:** It simply measures the time interval required for an electric current pulse to travel between two points. The two points of measurement are the fixed magnet located on the piston position

and the sensor at the end of the transducer probe. This concept has been successful in eliminating considerable expense for potentiometers, tach generators, encoders, racks, pinions, and other special hardware.

**ADVANTAGES PLUS:** Includes a non-contact operation, no wear, no noise generation, high reliability, infinite resolution (analog), high linearity (.05%), excellent repeatability (.002%), and direct digital output if required.

LDT Systems can be adapted to all NOPAK P6, H6 and H3 cylinder diameters with a 1-3/8" diameter rod or larger.

We welcome the opportunity to discuss your applications and help you supply your needs.

## NLDT SPECIFICATIONS

Electrical stroke	Standard - up to 25 feet.
Null	Positioned as required.
Null adjustment	2% of total stroke nominal.
Scale adjustment	1% of total stroke nominal.
Non-linearity	Less than $\pm 0.05\%$ of full range.
Repeatability	Better than $\pm 0.001\%$ of full range.
Temperature coefficient of scale factor	Transducer: less than 0.00011 inch/°F + [3 ppm/°F per inch of full stroke]. Analog Output Module: 20 ppm/°F.
Frequency response	Stroke dependent. 200 Hz to 50 Hz is typical for lengths of 12 inch to 100 inch respectively - wider response frequencies are available upon request. For digital systems, output is updated at discrete intervals.
Hysteresis	Less than 0.0008 in. maximum.
Output	Analog: 0 to +10 VDC, 4 to 20 mA ungrounded (others available). Digital: pulse width modulated signal, TTL compatible.
Operating impedance	10 ohms.
Operating temperature range	-35°F to 150°F (transducer probe to 180°F).
Storage temperature range	-40°F to 180°F.
Operation in hydraulic fluid	The .375 inch dia. transducer probe is capable of operating in hydraulic fluid and will withstand 3,000 PSI operating pressure.

## HOW TO ORDER

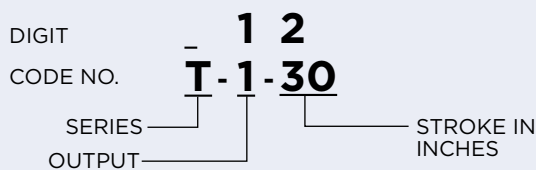

**When ordering: Code Number must be completed using options listed at right.**

For further detailed information contact your NOPAK distributor.

DIGIT	DESCRIPTION
<b>FIRST</b>	<b>OUTPUT</b> 1. 0 to +10 VDC w/Analog Output Module 2. 0 to +10 VDC w/built-in Analog Personality Module (Eliminates separate Analog Output Module) 3. 4 to 20 MA grounded w/Analog Output Module 4. Half digital w/Digital Personality Module 5. Full digital w/Digital Personality Module and Digital Counter Card. Specify Binary or BCD. 6. Digital with RS422 Personality Module 7. Others (specify)
<b>SECOND</b>	<b>ELECTRICAL STROKE IN INCHES (Example: 12.75 inches)</b> 1 - 1 Inch through 300 - 300 Inch (25 foot maximum)

DIMENSION VARIES ACCORDING TO CYLINDER DIAMETER AND PISTON ROD DIAMETER. (CONSULT FACTORY)

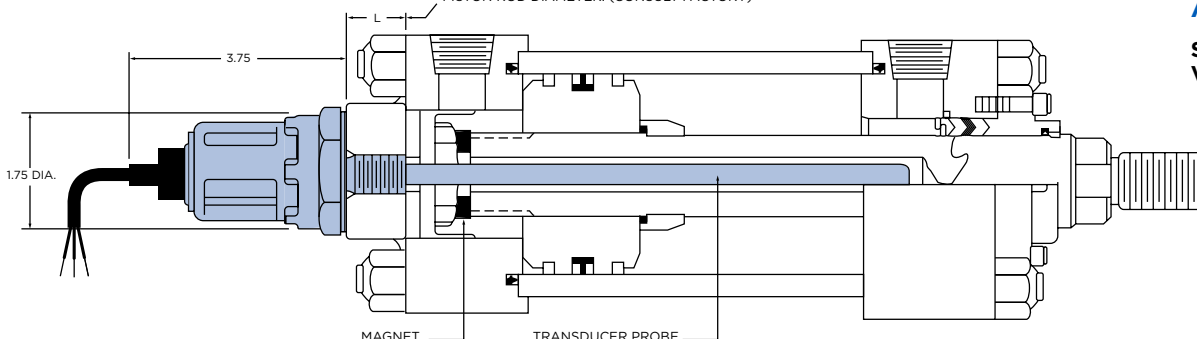

## ALSO AVAILABLE

Servo or Proportional Valve Footprint

NOPAK Class 3 pressure-rated cylinders are designed for hydraulic service. For reference to basic pressure ratings, see table page 26. Cylinders 1-1/2" through 8" diameter bore are assembled from standard inventory components. Special design and large diameter Class 3 cylinders are available. Send us your specifications.

**OPERATING TEMPERATURES AND MEDIA**

Class 3 hydraulic cylinders equipped with standard Type A packings may be operated at temperatures from -40°F to 225°F air, water or oil. The following chart relates in a simplified general purpose manner the limitations and uses of available piston and rod packings.

PACKING TYPE	
A = NITRILE (BUNA-N)	B = FLUOROCARBON
-40°F to +225°F Std. Hyd. Oil	-20°F to +325°F Std. Hyd. Oil
Air	Air
Water (not steam)	
Water Glycol Fire Resistant Fluid	Phosphate Ester Fire Resistant Fluid

*For specific media and temperature or conditions exceeding the chart ratings, consult NOPAK Engineering Department.*

Applications involving Fire Resistant Fluids must be so specified for compatible component materials. When considering temperature, remember that as the temperature increases (within the rated limits) the packing life decreases.

**INTERCHANGEABILITY**

Class 3 cylinders are dimensionally interchangeable with other square-head cylinders of the same pressure classification. Construction and performance are in conformance with applicable recommended NFPA Standards.

**CUSHIONS**

NOPAK Class 3 cylinders are available with adjustable cushions on either or both ends, or non-cushion.

The purpose of a cushion is to slow up piston speed at the end of the stroke, eliminating hammer and shock. Where standard cushions are inadequate for unusual requirements, special cushions possibly requiring longer-than-standard heads can be furnished at additional charge. Very rapid cushioning of high speed movement may require deceleration valves.

The purpose of the ball check in the cushion mechanism is to allow fluid to pass to the piston face without obstruction (while the cushion sleeve is still within the bore in the head). This results in essential quick starting of the piston. Cushion adjusting screws serve to bypass the fluid from the trapped section between the piston and the cylinder head when the cushion sleeve has entered the bore. Turning the needle inward against the seat results in maximum cushion intensity. Backing up on the needle decreases the effect.

**CYLINDER PORT TYPES & LOCATION**

Standard ports are NPT. SAE O-ring boss ports are available. SAE 4-bolt flange ports are offered at extra charge. Specify Code 61 or Code 62.

Inlet ports are located in Position 1 as standard (see rod end view on dimension drawings). They can however, be located at other numbered locations on application. Extra inlets furnished at additional charge. Oversize and special inlets require dimensions and quotation on application.

**WATER SERVICE**

Special cylinders can be built for water service. Due to the uncertainty of action of water supply on some materials, responsibility for premature failure due to corrosion, mineral deposits or electrolysis cannot be accepted.



## PRE-STRESSING TIE RODS

Some of the tie rod torque values shown in Table A may be impractical to obtain with an ordinary torque wrench. If so, another method for prestressing the tie rods may be used. Lightly tighten opposite tie rods alternately to a 100 ft. lb. torque value. Measure the stressed length of the tie rod (the distance between the nut faces

of thread engaged surfaces) and multiply this length by the proper "N" factor as specified in Table A. This will indicate the amount of turn or turns required. Scribe a reference mark on each nut and the adjacent bolted surface to assist in determining the amount of rotation. Slowly and evenly heat the exposed center length of the tie rod using caution not to overheat the tie rod or nearby cylinder or head surfaces. (If desired, use a fireproof heat shield for insulation of the cylinder barrel). When the tie rod is sufficiently heated the nut can be turned to the proper location. This procedure may be followed for the other tie rods in the alternate fashion until all the tie rods have been tightened the desired amount. After they have cooled, the tie rods will be stressed to the proper torque value.

### TABLE A - TIE ROD TORQUE

CYL. DIA.	1-1/2	2	2-1/2	3-1/4	4	5	6	7	8	10	12	14	16	18	20
No. of Tie Rod	4	4	4	4	4	4	4	4	4	12	16	8	8	12	12
Tie Rod Size	3/8	7/16	1/2	5/8	5/8	7/8	1	1-1/8	1-1/4	1	1	1-1/2	1-1/2	1-1/2	1-1/2
Torque Ft. Lbs.	20	45	60	150	150	400	600	850	1000	600	600	2500	2500	2500	2500
N. Factor	-	-	-	-	-	-	.043	.036	.040	.044	.044	.044	.043	.044	.043

### TABLE B - DEDUCTIONS FOR PULL STROKE FORCE AND DISPLACEMENT

ROD SIZE	ROD AREA SQ. IN.	ROD DIAMETER FORCE IN POUNDS FOR VARIOUS LINE PRESSURES							DISPLACEMENT PER INCH OF STROKE	
		500	750	1000	1250	1500	2000	3000	CU. INCH	GALLONS
5/8	.307	154	230	307	384	461	614	921	.307	.0013
1	.785	393	589	785	981	1178	1570	2355	.785	.0034
1-3/8	1.485	743	1114	1485	1856	2228	2970	4455	1.485	.0064
1-3/4	2.405	1203	1804	2405	3006	3608	4810	7215	2.405	.0104
2	3.142	1571	2357	3142	3928	4713	6284	9426	3.142	.0136
2-1/2	4.909	2455	3682	4909	6137	7364	9818	14,727	4.909	.0213
3	7.069	3535	5302	7069	8836	10,604	14,138	21,207	7.069	.0306
3-1/2	9.621	4811	7216	9621	12,026	14,432	19,242	28,863	9.621	.0416
4	12.566	6283	9425	12,566	15,708	18,849	25,132	37,698	12.566	.0544
4-1/2	15.904	7952	11,928	15,904	19,880	23,856	31,808	47,712	15.904	.0688
5	19.635	9818	14,726	19,635	24,544	29,452	39,270	58,905	19.635	.0850
5-1/2	23.758	11,879	17,819	23,758	29,698	35,637	47,516	71,274	23.758	.1028
7	38.484	19,242	28,863	38,484	48,105	57,726	76,968	115,452	38.484	.1666
8	50.265	25,133	37,699	50,265	62,831	75,398	100,530	150,795	50.265	.2176
9	63.617	31,809	47,713	63,617	79,521	95,426	127,234	190,851	63.617	.2754
10	78.539	39,270	58,904	78,539	98,174	117,809	157,079	235,617	78.539	.3400

#### NOTE:

To determine cylinder pull stroke force or displacement, deduct force or displacement corresponding to rod size in Table B from force or displacement corresponding to bore size shown in Table C.

1 gallon = 231 Cu. In.

Area of Circle = .7854 d<sup>2</sup>

Piston Speed (In./Min.) =  $\frac{\text{Pressure Source Delivery (GPM)}}{\text{Cylinder Displacement (Gal./In.)}}$

### TABLE C - THRUST FORCE AND DISPLACEMENT

BORE SIZE	PISTON AREA SQ. IN.	CYLINDER THRUST FORCE IN POUNDS FOR VARIOUS LINE PRESSURES							DISPLACEMENT PER INCH OF STROKE	
		500	750	1000	1250	1500	2000	3000	CU. INCH	GALLONS
1-1/2	1.767	884	1,325	1,767	2,209	2,650	3,534	5,301	1.767	.00765
2	3.142	1,571	2,357	3,142	3,928	4,713	6,284	9,426	3.142	.0136
2-1/2	4.909	2,455	3,682	4,909	6,137	7,364	9,818	14,727	4.909	.0213
3-1/4	8.296	4,148	6,222	8,296	10,370	12,444	16,592	24,888	8.296	.0359
4	12.566	6,283	9,425	12,566	15,708	18,849	25,132	37,698	12.566	.0544
5	19.635	9,818	14,726	19,635	24,544	29,452	39,270	58,905	19.365	.0850
6	28.274	14,137	21,206	28,274	35,342	42,411	56,548	84,822	28.274	.1224
7	38.485	19,242	28,864	38,485	48,106	57,727	76,970	115,455	38.485	.1666
8	50.265	25,133	37,699	50,265	62,832	75,398	100,530	150,795	50.265	.2176
10	78.54	39,270	58,905	78,540	98,175	117,810	157,080	235,620	78.54	.3400
12	113.10	56,550	84,825	113,100	141,375	169,650	226,200	339,300	113.10	.4896
14	153.94	76,970	115,455	153,940	192,425	230,910	307,880	461,820	153.94	.666
16	201.06	100,530	150,795	201,060	251,325	301,590	402,120	603,180	201.06	.870
18	254.47	127,235	190,853	254,470	318,088	381,705	508,940	763,410	254.47	1.102
20	314.16	157,080	235,620	314,160	392,700	471,240	628,320	942,480	314.16	1.360

**INFORMATION TO PREVENT EXCESSIVE BEARING WEAR AND PISTON ROD COLUMN FAILURES**

**GROUP A – WITH PISTON RODS EXTENDED**

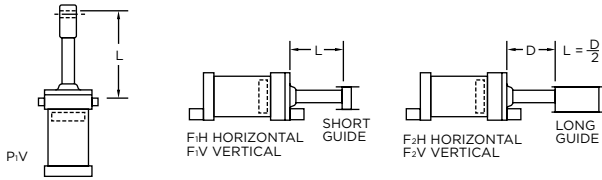

**GROUP B – TO BE CHECKED FOR BUCKLING OR JACK-KNIFING WITH PISTON RODS EXTENDED AND VERTICALLY MOUNTED**

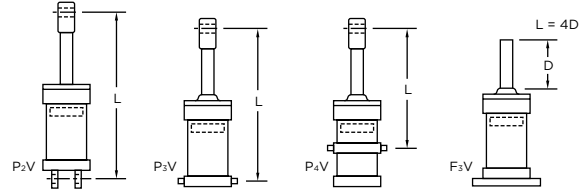

**GROUP C – TO BE CHECKED FOR LOAD ON BEARING WITH PISTON RODS EXTENDED AND HORIZONTALLY MOUNTED**

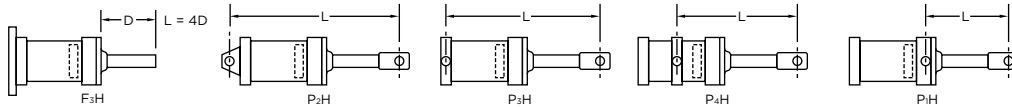

**STEP 1** – Find drawing in one of three groups above that fits your cylinder application and follow instructions listed for that group.

**Instructions:** Stop tubes are used on long push stroke cylinders to prevent jack-knifing or buckling. They are placed between the piston and cylinder head to restrict the extended position of the piston rod so that the lengthened space between piston and bushing provides additional piston rod guide support.

**The best choice for a cylinder with an exceptionally long stop tube requirement is the DOUBLE PISTON WITH SPACER. Note that the piston effective bearing area is doubled in addition to gaining the normal increased minimum distance between bearing points.**

To determine whether a stop tube is required on a push stroke cylinder, proceed as follows:

- Using above drawings, determine value of “L” from stroke length, rod and cylinder dimensions.
- Refer to TABLE A – Minimum and Maximum Stop Tube Lengths on page 67 for stop tube recommendation. A cylinder having an “L” value 45 requires a minimum of 1” stop tube and a maximum of 5” stop tube. Specifications for more than the maximum stop tube will usually adversely increase the cylinder weight.

**Example:** In a P<sub>2</sub>V type application requiring 32” of stroke, “L” = 32” + 32” + approximately 10” for head and cap thickness = 74”. A stop tube 4” long is required (when a fraction of an inch of stop tube is calculated, use the next full inch.) Adjusted value of “L” is 74” + 4” or 78”. Use of up to 8” of stop tube will further reduce bearing loads.

**Instructions:** Stop tubing is recommended for reducing piston and bushing/bearing loads on long stroke cylinders of the types shown. To determine length of stop tube required for this type of application, resolve the turning moments and loads between the piston and rod bushing. Include the weight of the fluid, especially on large bore cylinders. It is ideal to keep projected bearing area loads lower than 200 PSI.

**Caution:** Do not use oversize rods to lessen bearing loads. Stop tubes are more economical and effective; oversize rods are heavier, cost more than stop tubing and if misalignment occurs, bearing loads are considerably increased due to stiffness of the oversize rod.

If your drawing is F<sub>3</sub>H, P<sub>2</sub>H, P<sub>3</sub>H, or P<sub>4</sub>H, in Group C, check for stop tube requirements from instructions in Group B.

Use whichever stop tube is longer. Determine value of “L” and proceed to Step 2.

**STEP 2** – Find Rod Diameter for Column Strength.

Standard diameter piston rods are recommended on all installations except where column strength, piston rod sag, or return rate of hydraulic cylinders requires larger diameter rods.

Bushing/bearing loads caused by unavoidable misalignment are minimized when piston rods of correct diameter instead of unnecessarily large diameter piston rods are used. Correct (usually standard) piston rod diameters decrease and absorb shock loads to a greater extent than unnecessarily large oversize rods.

To determine the minimum piston rod diameter on push stroke cylinders:

- Determine your push stroke thrust from TABLE C – Thrust Force and Displacement on page 65.
- Find your push stroke thrust “T” in TABLE B – Value of “L” In Inches on page 67. If exact thrust isn’t shown, use next larger shown.
- In the horizontal column in line with your thrust, find value of “L” determined in Step 1.
- Find minimum piston rod diameter required by following the same vertical line where your value of “L” is located, toward the top of the table.

**TABLE A - MINIMUM AND MAXIMUM STOP TUBE LENGTHS**

"L" INCHES	MINIMUM STOP TUBE LENGTH (INCHES)	MAXIMUM STOP TUBE LENGTH (INCHES)	"L" INCHES	MINIMUM STOP TUBE LENGTH (INCHES)	MAXIMUM STOP TUBE LENGTH (INCHES)	"L" INCHES	MINIMUM STOP TUBE LENGTH (INCHES)	MAXIMUM STOP TUBE LENGTH (INCHES)
5-10	-	1	111-120	8	12	211-220	18	22
11-20	-	2	121-130	9	13	221-230	19	23
21-30	-	3	131-140	10	14	231-240	20	24
31-40	-	4	141-150	11	15	241-250	21	25
41-50	1	5	151-160	12	16	251-260	22	26
51-60	2	6	161-170	13	17	261-270	23	27
61-70	3	7	171-180	14	18	271-280	24	28
71-80	4	8	181-190	15	19	281-290	25	29
81-90	5	9	191-200	16	20	291-300	26	30
91-100	6	10	201-210	17	21	301-310	27	31
101-110	7	11						

**NOTE:** Using stop tube lengths greater than "Maximum Stop Tube" has diminishing effect on reducing bearing loads.

**TABLE B - VALUE OF "L" IN INCHES**

VALUE OF "T" IN LBS. IN THIS COLUMN	PISTON ROD DIAMETERS															
	0.63	1.00	1.38	1.75	2.00	2.50	3.00	3.50	4.00	4.50	5.00	5.50	7.00	8.00	9.00	10.00
1,000	27	60	105	155	190	257	330									
1,400	24	53	92	142	174	244	308	385								
1,800	23	48	82	127	160	230	296	366	440							
2,400	19	45	75	114	145	213	281	347	415	488						
3,200	16	41	67	103	130	194	261	329	400	461						
4,000	13	38	63	94	119	175	240	310	378	446						
5,000	9	34	60	87	110	163	225	289	360	426	494					
6,000		30	56	82	102	152	208	274	342	410	476					
8,000		26	50	76	93	137	188	245	310	375	447					
10,000		21	45	70	89	125	172	222	279	349	412	482				
12,000		17	41	65	84	118	155	210	269	326	388	454				
16,000			34	57	75	110	142	188	235	292	350	420				
20,000			28	52	68	103	136	172	218	270	326	385				
30,000				39	55	87	120	156	189	230	285	330				
40,000				22	43	74	108	142	177	210	248	294				
50,000					30	66	96	130	165	200	234	269	408			
60,000						57	88	119	154	190	225	256	384			
80,000						36	71	104	137	170	204	240	336			
100,000							57	90	120	154	189	222	324	400		
120,000							45	77	108	140	175	207	313	377		
140,000								64	98	128	160	194	301	365		
160,000								47	86	118	148	182	279	350	421	
200,000									67	98	131	161	260	330	402	
250,000										72	109	141	236	301	375	
300,000											86	120	212	281	351	420
350,000											52	100	195	261	328	396
400,000												77	182	241	309	374
500,000													152	212	274	341
600,000													114	183	247	310
700,000													70	162	221	280
800,000														118	197	260
900,000														82	168	237
1,000,000														115	115	212

Values of "L" less than those shown have a slenderness ratio (length ÷ radius of gyration which is length ÷ 1/4 diameter of piston rod) of less than 50. Thus, the compressive strength formula ( $s = \text{thrust} \div \text{rod area}$ ) is used rather than the column strength formula on which Table B is based. For very low slenderness ratios (below 20), compressive strength formulae with a 2 to 1 factor of safety are satisfactory. For slenderness ratios between 20 and 50, use compressive strength formulae with proportionate factors between 2 to 1 and 5 to 1.

## EXPLODED VIEW

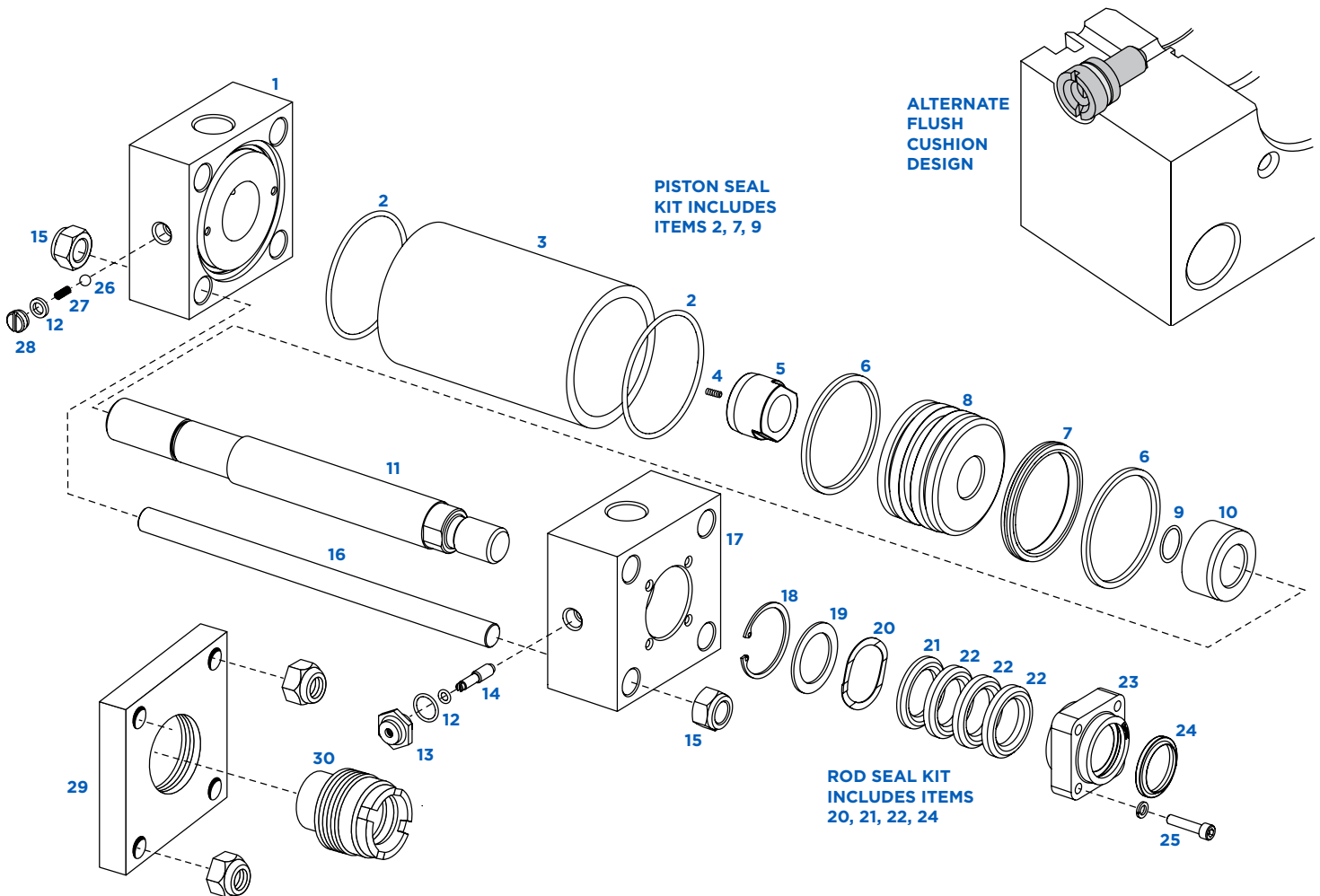

- |                                    |   |                                   |
|------------------------------------|---|-----------------------------------|
| <b>1</b> Blind end head            | <b>12</b> Seal                          | <b>23</b> Packing gland▲          |
| <b>2</b> Tube seal•                | <b>13</b> Cushion adjusting screw gland | <b>24</b> Rod wiper•              |
| <b>3</b> Tube                      | <b>14</b> Cushion adjusting screw       | <b>25</b> Packing gland cap screw |
| <b>4</b> Lock screw                | <b>15</b> Tie rod nut                   | <b>26</b> Check ball              |
| <b>5</b> Lock sleeve               | <b>16</b> Tie rod                       | <b>27</b> Ball check spring       |
| <b>6</b> Piston ring               | <b>17</b> Rod end head                  | <b>28</b> Ball check plug         |
| <b>7</b> "T" seal and back-ups•▲   | <b>18</b> Retainer ring▲                |                                   |
| <b>8</b> Piston                    | <b>19</b> Packing spacer▲               | <b>IF APPLICABLE:</b>             |
| <b>9</b> Piston O-ring•            | <b>20</b> Wave spring•▲                 | <b>29</b> Head plate              |
| <b>10</b> Cushion sleeve - rod end | <b>21</b> Bottom adapter ring•■▲        | <b>30</b> Screw gland             |
| <b>11</b> Piston rod               | <b>22</b> Rod packing•▲                 |                                   |

▲ = "T" seal used through 16" diameter bore; 18" and 20" fitted with piston rings.

▲ = For 7" diameter rods and larger:

Part 18, 19, 20 and 21 are eliminated

Part 22 replaced by a U-cup style seal

Part 23 replaced by a rod bearing and a multi-bolt gland retainer.

• = Items are included in seal repair kits. See page 69 for ordering information.

■ = Item 21 is metallic for high temp. applications.

**When ordering replacement parts be sure to specify:**

- Part by name and item number
- Bore, stroke and mounting
- Serial number shown on NOPAK label

**NOTE:** Isometric view of Double Rod cylinders available at N/C. Consult factory or an authorized distributor.

## REPAIR KITS - CLASS 3

### ROD SEAL KITS

SINGLE ROD •	
ROD DIA.	PART NO. ■
0.63"	RK3-63
1.00"	RK3-100
1.38"	RK3-138
1.75"	RK3-175
2.00"	RK3-200
2.50"	RK3-250
3.00"	RK3-300
3.50"	RK3-350
4.00"	RK3-400
4.50"	RK3-450
5.00"	RK3-500
5.50"	RK3-550
7.00"	RK3-700

Each Rod Seal Kit consists of:

- 1 - V-ring rod packing
- 1 - Rod wiper
- 1 - Wave spring

• = To service Double Rod End Cylinder, order one Rod Kit for EACH rod end, and if applicable, one Piston Kit.

### PISTON SEAL KITS

SINGLE OR DOUBLE ROD	
BORE SIZE	PART NO. ■
1.50"	PK3-150
2.00"	PK3-200
2.50"	PK3-250
3.25"	PK3-325
4.00"	PK3-400
5.00"	PK3-500
6.00"	PK3-600
7.00"	PK3-700
8.00"	PK3-800
10.00"	PK3-1000
12.00"	PK3-1200
14.00"	PK3-1400

Each Piston Seal Kit consists of:

- 2 - Tube O-rings
- 1 - G. T. ring (piston seal)
- 1 - Piston O-ring

**NOTE:** Cast iron rings NOT included.

■ = When ordering, specify Type "A" or Type "B" seals.  
 Type "A" = Buna-N (NITRILE)  
 Type "B" = Fluorocarbon

## PACKING GLANDS - CLASS 3

ROD DIA.	ALL MODELS EXCEPT D & DD ■	MODELS D & DD ONLY
	PART NUMBER	PART NUMBER
0.63"	1069G70	1071G70
1.00" •	1068G73	2859G73
1.38" •	1066G75	2858G75
1.75" •	1067G77	2857G77
2.00"	1065G78	2856G78
2.50"	1064G79	2855G79
3.00"	1063G81	2854G81
3.50"	1062G82	2853G82
4.00"	1061G83	2852G83
4.50"	1060G84	C/F
5.00"	1070G85	C/F
5.50"	1059G86	C/F
7.00"	C/F	C/F

- = Use packing gland 2859G73 for 1.50" cyl. with 1.00" Ø rod  
 Use packing gland 2858G75 for 2.00" cyl. with 1.38" Ø rod  
 Use packing gland 2857G77 for 2.50" cyl. with 1.75" Ø rod

■ = For Models AL, T and TR, consult factory.

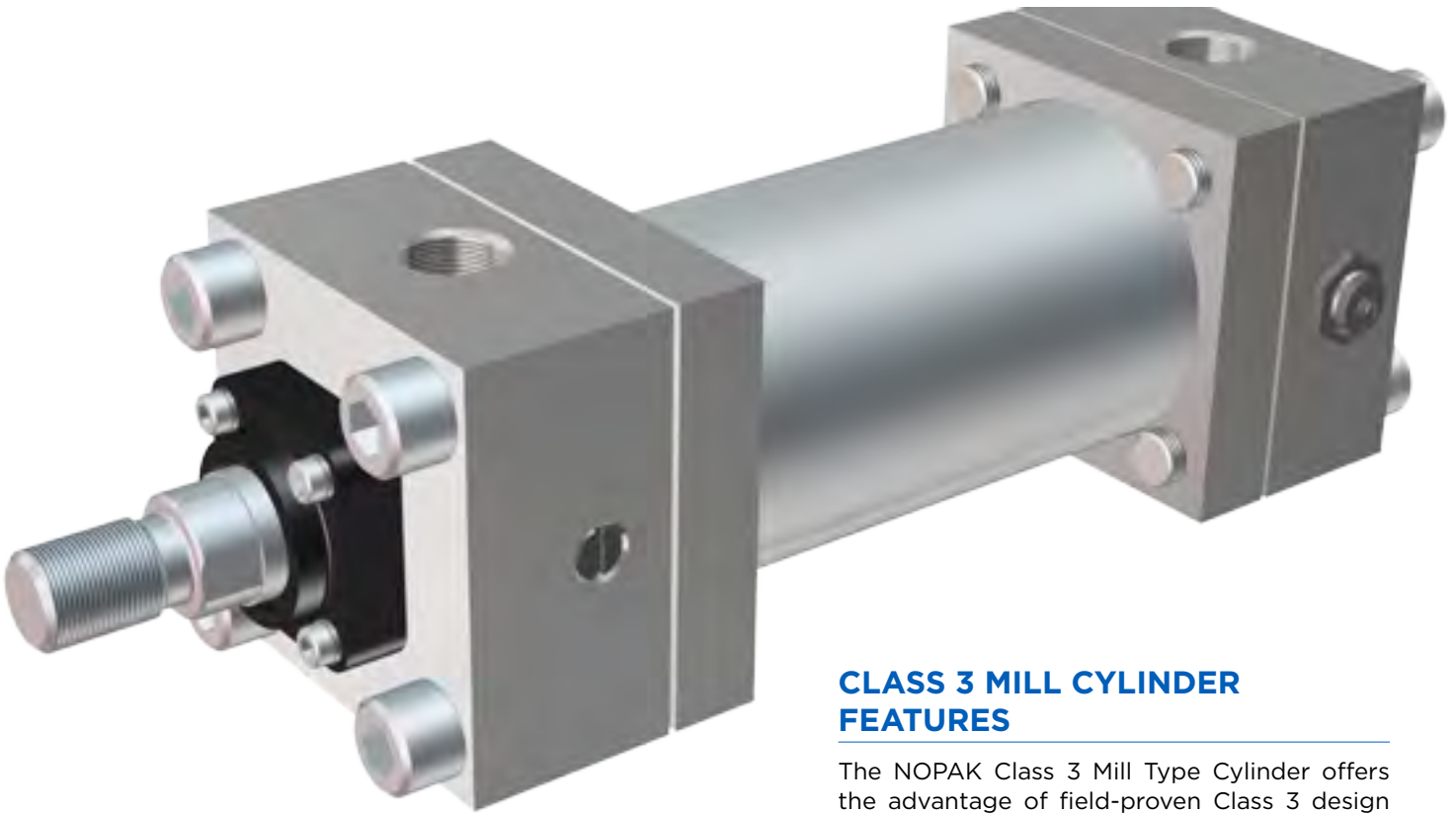

### **CLASS 3 MILL CYLINDER FEATURES**

The NOPAK Class 3 Mill Type Cylinder offers the advantage of field-proven Class 3 design integrity in a non-tie-rod unit. Using Grade 8 fasteners we bolt NOPAK production cylinder heads to square flanges that have been welded to both ends of the cylinder tube.

All the features found in NOPAK's Class 3 are incorporated in the 3M series. A long list of options, including dual piston stop tube, integral LDT (Linear Displacement Transducer), servo or proportional valve footprint in cylinder head, and multiple mounting styles are available.

# Class 5A

Low Pressure NFPA Aluminum Cylinders

---

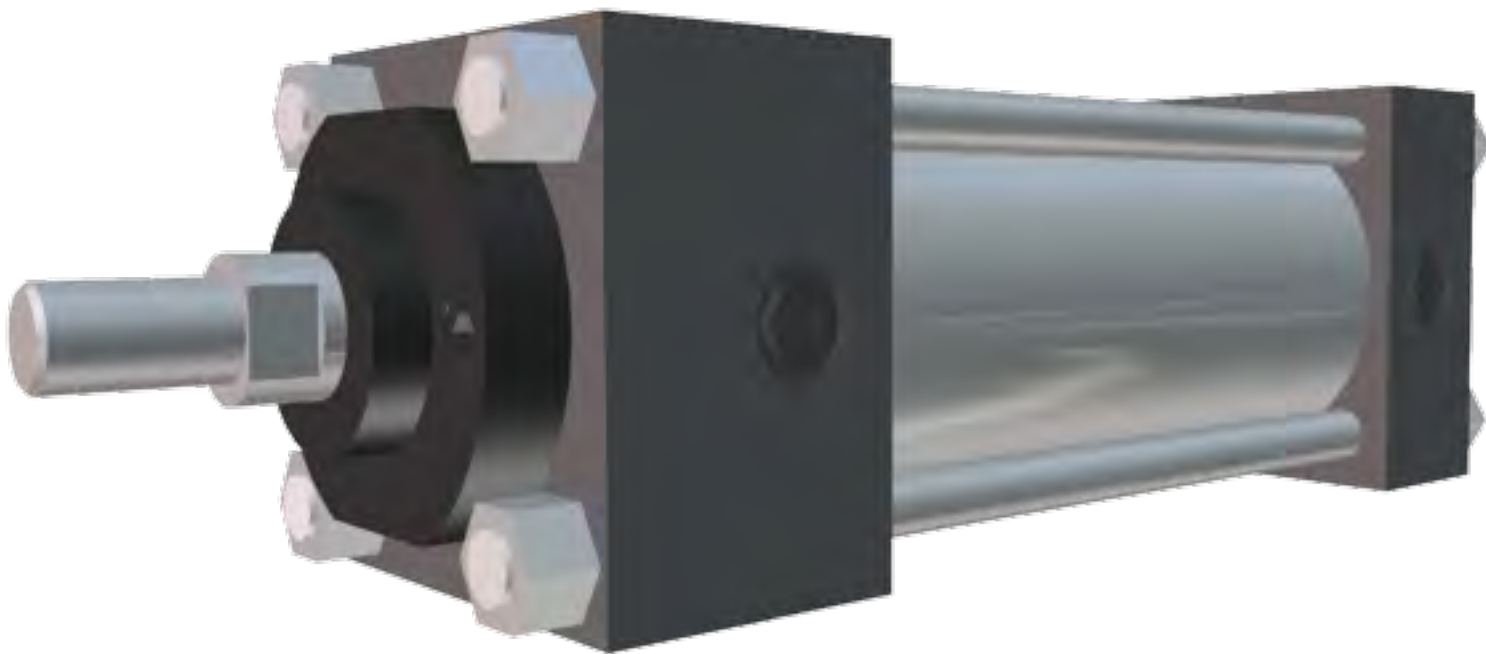

# NOPAK

First in Manufacturing. Engineered to Last.

**TABLE OF CONTENTS**

Mounting Styles Index . . . . . 72

How To Order . . . . . 73

    Ordering Code Example . . . . . 73

    Combination Mounts . . . . . 73

Class 5A Features . . . . . 74

Piston Rod Dimension Data . . . . . 75

Flange Mount Cylinders  
1.50" Through 12.00" Bore . . . . . 76

Clevis and Eye  
Mount Cylinders  
1.50" Through 12.00" Bore . . . . . 78

Angle and Side Lug  
Mount Cylinders  
1.50" Through 12.00" Bore . . . . . 80

Trunnion Mount Cylinders  
1.50" Through 8.00" Bore . . . . . 82

Tie Rod Mount Cylinders  
1.50" Through 12.00" Bore . . . . . 84

Double Rod End Cylinders  
1.50" Through 12.00" Bore . . . . . 86

Technical Data . . . . . 87

Accessories . . . . . 88

Options and Modifications . . . . . 90

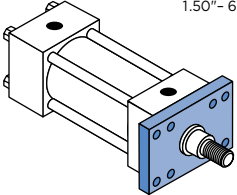
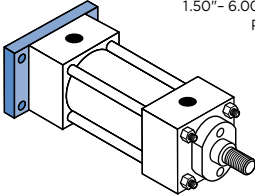
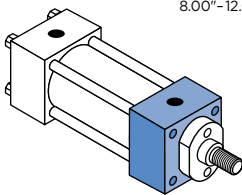
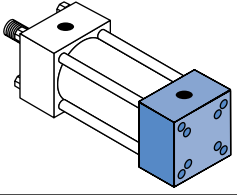
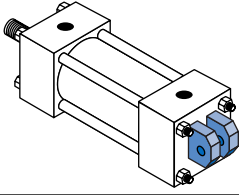
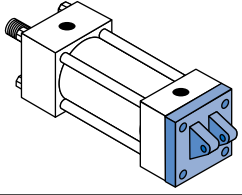
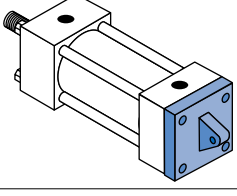
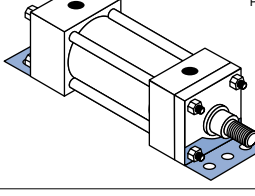
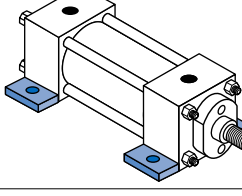
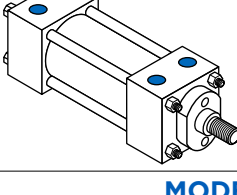
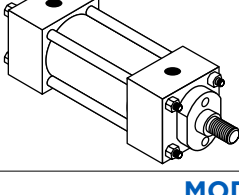
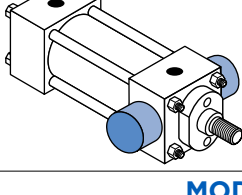
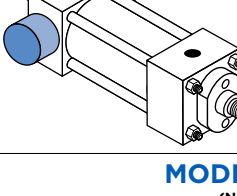
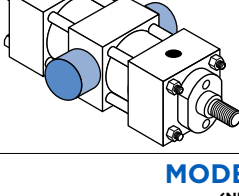
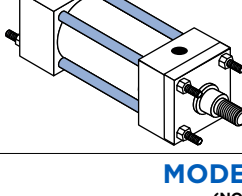
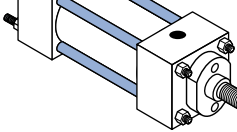
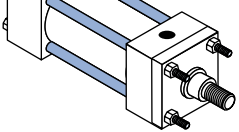
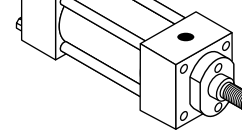
<p><b>MODEL D</b> (NFPA MF1) 1.50"- 6.00" BORE PAGE 76</p> 	<p><b>MODEL C</b> (NFPA MF2) 1.50"- 6.00" BORE PAGE 76</p> 	<p><b>MODEL DG</b> (NFPA ME3) 8.00"-12.00" BORE PAGE 76</p> 
<p><b>MODEL CJ</b> (NFPA ME4) 8.00"-12.00" BORE PAGE 76</p> 	<p><b>MODEL E</b> (NFPA MP1) 1.50"-12.00" BORE PAGE 78</p> 	<p><b>MODEL HE</b> (NFPA MP2) 1.50"- 6.00" BORE PAGE 78</p> 
<p><b>MODEL E4</b> (NFPA MP4) 1.50"- 6.00" BORE PAGE 78</p> 	<p><b>MODEL AP</b> (NFPA MS1) 1.50"- 8.00" BORE PAGE 80</p> 	<p><b>MODEL A</b> (NFPA MS2) 1.50"- 8.00" BORE PAGE 80</p> 
<p><b>MODEL S</b> (NFPA MS4) 1.50"-12.00" BORE PAGE 80</p> 	<p><b>MODEL H</b> (NO MOUNT) 1.50"-12.00" BORE PAGE 80</p> 	<p><b>MODEL FR</b> (NFPA MT1) 1.50"- 8.00" BORE PAGE 82</p> 
<p><b>MODEL FB</b> (NFPA MT2) 1.50"- 8.00" BORE PAGE 82</p> 	<p><b>MODEL F</b> (NFPA MT4) 1.50"- 8.00" BORE PAGE 82</p> 	<p><b>MODEL T</b> (NFPA MX1) 1.50"-12.00" BORE PAGE 84</p> 
<p><b>MODEL TB</b> (NFPA MX2) 1.50"-12.00" BORE PAGE 84</p> 	<p><b>MODEL TR</b> (NFPA MX3) 1.50"-12.00" BORE PAGE 84</p> 	<p><b>MODEL XH</b> (NO MOUNT) 1.50"-12.00" BORE PAGE 86</p> 



## ORDERING CODE EXAMPLE

**CL5A - 4.00 x 12.00 - E\* - AA - 1.00 - 4 - OPT**

CLASS		STROKE		ROD DIAMETER		ROD END THREAD		CUSHIONS		OPTIONS	
5A	250 PSI AIR ALUMINUM	UP TO 120"		SEE CHART AT RESPECTIVE BORE SIZE FOR ROD SIZES AVAILABLE		SEE CHART PAGE 75)				(CALL OUT BELOW CYLINDER DESCRIPTION)	
<b>Bore</b>		<b>MODEL</b>		<b>ROD END THREAD</b>		<b>CUSHIONS</b>				TYPE B SEALS - FLUOROCARBON	
1.50		D	MF1 - FRONT FLANGE	1 FULL MALE THREAD		NN NO CUSHIONS				DIM. WF - ROD EXTENSION	
2.00		C	MF2 - REAR FLANGE	3 INTERMEDIATE MALE		AA CUSHIONED BOTH ENDS				DIM. A - EXTENDED ROD THREAD	
2.50		DG	ME3 - FRONT MOUNTING HOLES	4 SMALL MALE (STANDARD)		NA NO CUSHION ROD END CUSHIONED BLIND END				EMS-201: ELECTROLESS NICKEL PLATING (SEE PAGE 92)	
3.25		CJ	ME4 - REAR MOUNTING HOLES	5 FEMALE THREAD		AN CUSHIONED ROD END NO CUSHION BLIND END				MAGNETIC PISTON	
4.00		E	MP1 - FIXED REAR CLEVIS	6 PLAIN END (NO THREADS)						METALLIC ROD SCRAPER	
5.00		HE	MP2 - DETACHABLE REAR CLEVIS	7 ROD COUPLER END						OPTIONAL PORT LOCATIONS	
6.00		E4	MP4 - DETACHABLE REAR EYE	9 STUDDED						STAINLESS STEEL PISTON ROD	
8.00		AP	MS1 - ANGLE PLATE							STAINLESS STEEL TIE RODS	
10.00		A	MS2 - FOOT MOUNT							STAINLESS STEEL TIE ROD NUTS	
12.00		S	MS4 - SIDE TAPPED HOLES							STAINLESS STEEL FASTENERS	
		FR	MT1 - FRONT TRUNNION							STAINLESS STEEL ALL: INCLUDES PISTON ROD, TIE RODS, TIE ROD NUTS AND FASTENERS	
		FB	MT2 - REAR TRUNNION							STAINLESS STEEL CUSHION NEEDLES	
		F	MT4 - INTERMEDIATE TRUNNION							STOP TUBE - SPECIFY STOP TUBE LENGTH, EFFECTIVE STROKE AND TOTAL STROKE	
		H	NO MOUNT								
		T	MX1 - EXTENDED TIE RODS (BOTH ENDS)								
		TB	MX2 - EXTENDED TIE RODS (CAP END)								
		TR	MX3 - EXTENDED TIE RODS (ROD END)								

\* FOR DOUBLE ROD END CYLINDERS, ADD AN "X" BEFORE THE MODEL IDENTIFICATION (EXAMPLE: XA, XD, XFR).

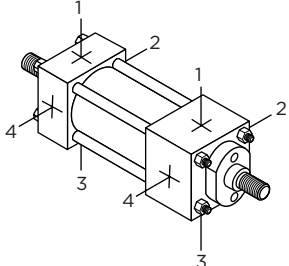
STANDARD PORT AND CUSHION ADJUSTMENT POSITIONS	
• PORTS - POSITION 1	
• CUSHION ADJUSTMENT - POSITION 2	
<p><b>NOTE:</b> When optional port locations are ordered, specify both port locations, even if one port is in the standard location.</p>	

## COMBINATION MOUNTS

Cylinders can be ordered with a combination of mounts for added design flexibility.

### HOW TO ORDER:

Combination mount part numbers can be constructed by adding a dash (-) in between the desired mounts in the part number. Consult factory for more information.

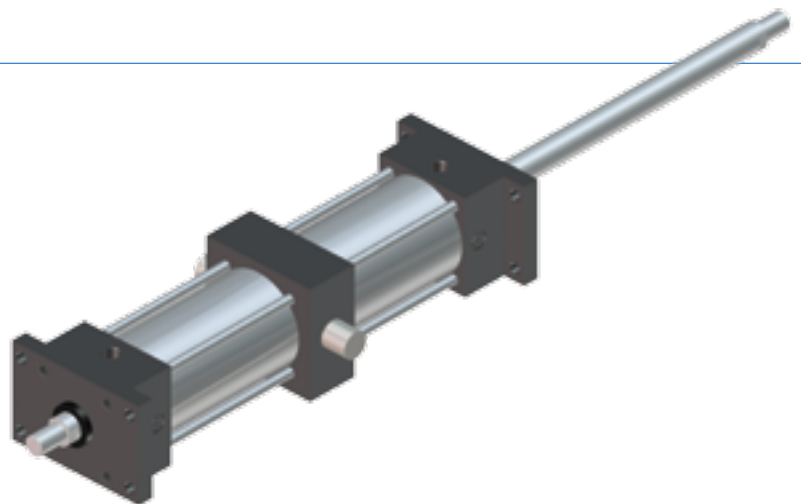

**CLASS 5A ALUMINUM NFPA CYLINDERS**

**HEAVY-DUTY DESIGN FOR RELIABLE, CONSISTENT OPERATION**

<b>OPERATING PRESSURE</b>	250 PSI Air	
<b>OPERATING TEMPERATURE</b>	Type A (Nitrile):	20°F to 200°F (-25°C to 90°C)
	Type B (Fluorocarbon):	0°F to 400°F (-20°C to 200°C)

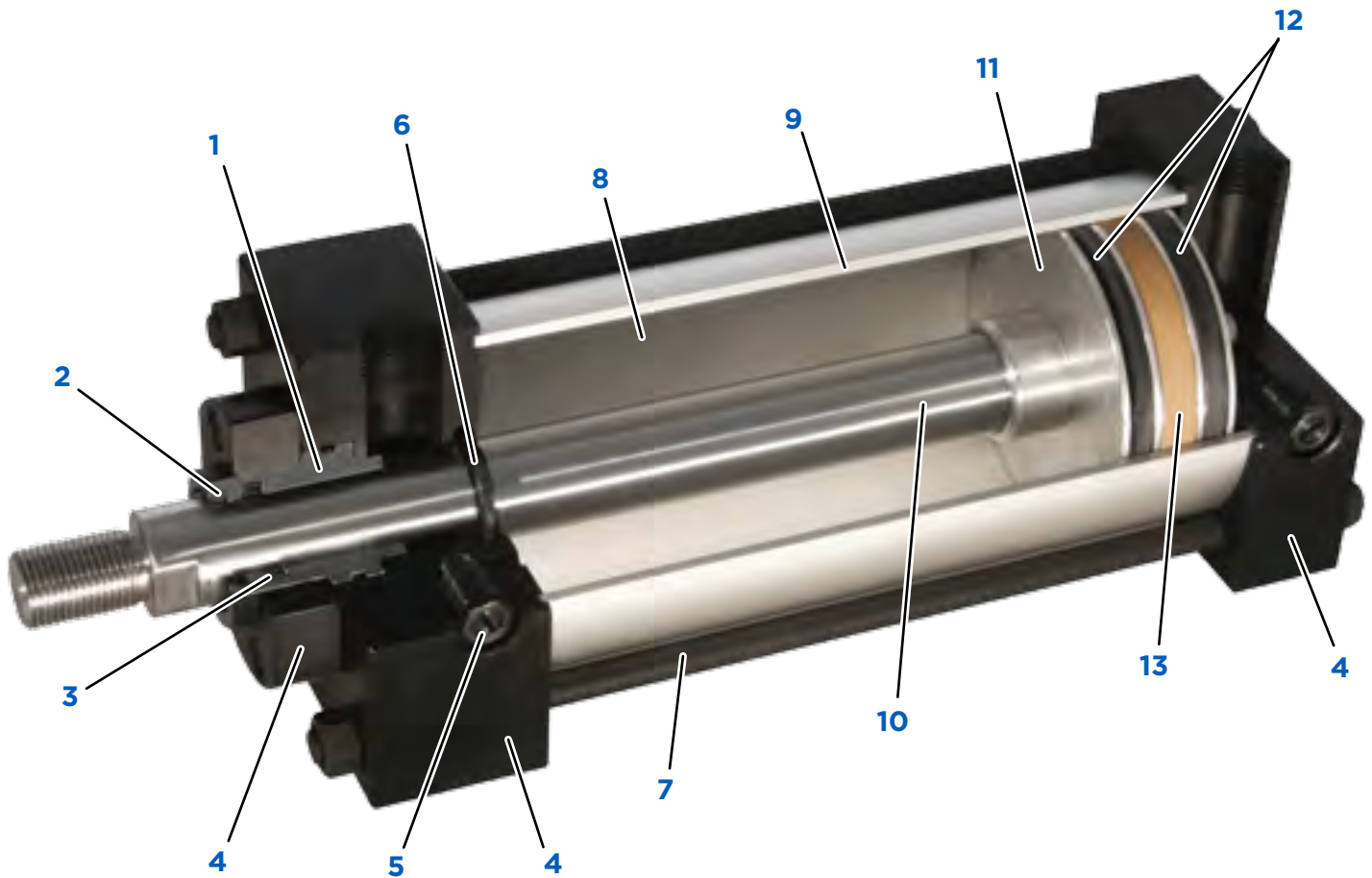

**1. ROD BUSHING -**

Precision machined from 150,000 PSI rated graphite-filled cast iron and PTFE coated to reduce friction and extend cycle life. Bushing design traps lubrication in effective bearing area.

**2. ROD WIPER -**

Abrasion resistant urethane provides aggressive wiping action in all environments. External lip design prevents debris from entering cylinder.

**3. ROD SEALS -**

Heavy lip design Carboxylated Nitrile construction. Seals are pressure activated and wear-compensating for long life (self-lubricating material).

**4. HEAD, CAP & RETAINER -**

Precision machined from high strength 6061-T6 aluminum alloy. Black anodized for corrosion resistance.

**5. CUSHION ADJUSTMENT NEEDLE -**

Adjustable steel needle design has fine thread metering and is positively captured to prevent needle ejection during adjustment.

**6. CUSHIONS -**

Floating cushion seal designed for maximum cushion performance, quick return stroke break-away and extended life.

**7. TIE RODS -**

Pre-stressed high carbon steel tie rod construction eliminates axial loading of cylinder tube and maintains compression on tube and end seals.

**8. PERMANENT LUBRICATION -**

Permanently lubricated with Magnalube-G PTFE based grease on all internal components. This is a non-migratory type high performance grease providing outstanding service life. No additional lubrication is required.

**9. CYLINDER TUBE -**

Precision machined from 6063-T6832 high tensile aluminum alloy and hard coat to 60 Rc for wear resistance and extended cycle life.

**10. PISTON ROD -**

Precision machined from high yield, polished and hard chrome plated steel.

**11. PISTON -**

Precision machined from 6061-T651 aluminum alloy, provides an excellent bearing surface for extended cylinder life.

**12. PISTON SEALS -**

Heavy lip design Carboxylated Nitrile construction. Seals are pressure activated and wear-compensating for long life (self-lubricating material).

**13. PISTON WEAR BAND -**

90% Virgin PTFE and 10% Polyphenylene Sulfide-filled wear band; extremely low wear rate.

# PISTON ROD DIMENSION DATA

## ABOUT ROD END TYPES

Type 4\* Male Rod End is STANDARD.

Other NFPA Styles are available (see chart).

Special rod ends are available, including metric threads, coarse (UNC) threads, etc. Consult factory for more information. For custom thread lengths, specify Dim. A = (length).

### PISTON ROD END TYPES

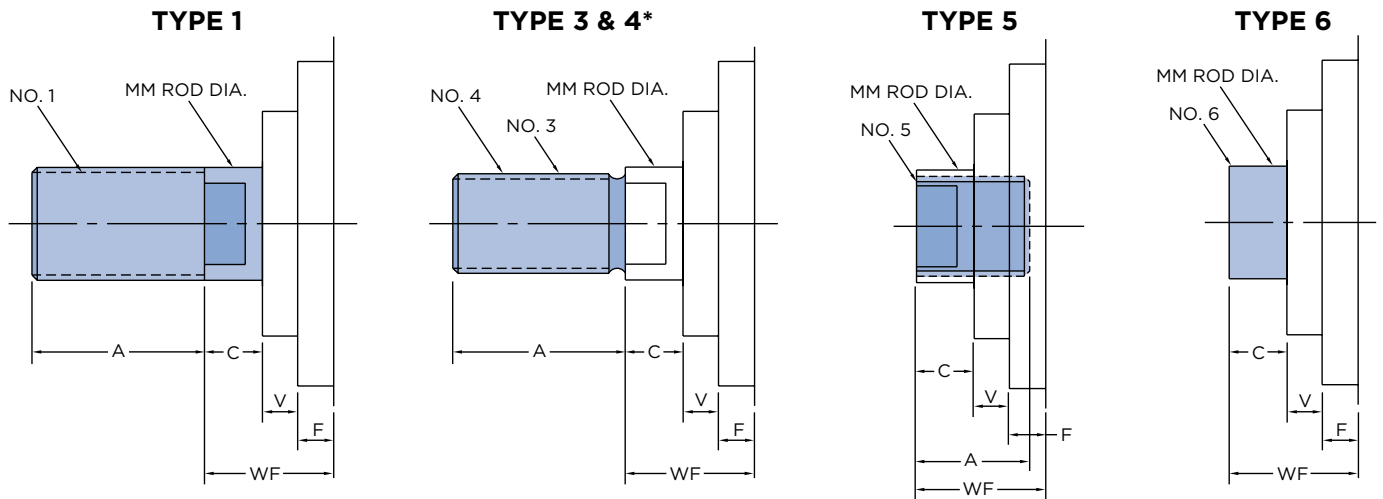

BORE	ROD MM	ROD END TYPE					A	C	F	V	WF
		NO. 1	NO. 3	NO. 4*	NO. 5	NO. 6					
1.50	0.63	0.63-18	0.50-20	0.44-20	0.44-20	No Threads	0.75	0.38	0.38	0.25	1.00
	1.00	1.00-14	0.88-14	0.75-16	0.75-16	No Threads	1.13	0.50	0.38	0.50	1.38
2.00	0.63	0.63-18	0.50-20	0.44-20	0.44-20	No Threads	0.75	0.38	0.38	0.25	1.00
	1.00	1.00-14	0.88-14	0.75-16	0.75-16	No Threads	1.13	0.50	0.38	0.50	1.38
2.50	0.63	0.63-18	0.50-20	0.44-20	0.44-20	No Threads	0.75	0.38	0.38	0.25	1.00
	1.00	1.00-14	0.88-14	0.75-16	0.75-16	No Threads	1.13	0.50	0.38	0.50	1.38
3.25	1.00	1.00-14	0.88-14	0.75-16	0.75-16	No Threads	1.13	0.50	0.63	0.25	1.38
	1.38	1.38-12	1.25-12	1.00-14	1.00-14	No Threads	1.63	0.63	0.63	0.38	1.63
4.00	1.00	1.00-14	0.88-14	0.75-16	0.75-16	No Threads	1.13	0.50	0.63	0.25	1.38
	1.38	1.38-12	1.25-12	1.00-14	1.00-14	No Threads	1.63	0.63	0.63	0.38	1.63
5.00	1.00	1.00-14	0.88-14	0.75-16	0.75-16	No Threads	1.13	0.50	0.63	0.25	1.38
	1.38	1.38-12	1.25-12	1.00-14	1.00-14	No Threads	1.63	0.63	0.63	0.38	1.63
6.00	1.38	1.38-12	1.25-12	1.00-14	1.00-14	No Threads	1.63	0.63	0.63	0.38	1.63
	1.75	1.75-12	1.50-12	1.25-12	1.25-12	No Threads	2.00	0.75	0.63	0.50	1.88
8.00	1.38	1.38-12	1.25-12	1.00-14	1.00-14	No Threads	1.63	0.63	0.63	0.38	1.63
	1.75	1.75-12	1.50-12	1.25-12	1.25-12	No Threads	2.00	0.75	0.63	0.50	1.88
10.00	1.75	1.75-12	1.50-12	1.25-12	1.25-12	No Threads	2.00	0.75	0.63	0.50	1.88
	2.00	2.00-12	1.75-12	1.50-12	1.50-12	No Threads	2.25	0.88	0.75	0.38	2.00
12.00	2.00	2.00-12	1.75-12	1.50-12	1.50-12	No Threads	2.25	0.88	0.75	0.38	2.00
	2.50	2.50-12	2.25-12	1.88-12	1.88-12	No Threads	3.00	1.00	0.75	0.50	2.25

**MODEL D (NFPA MF1) 1.50" - 6.00" BORES**

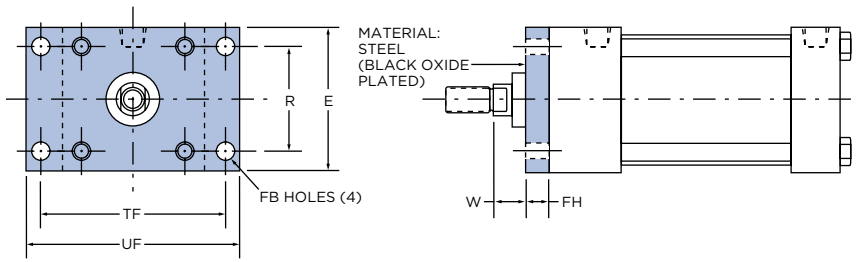

**MODEL C (NFPA MF2) 1.50" - 6.00" BORES**

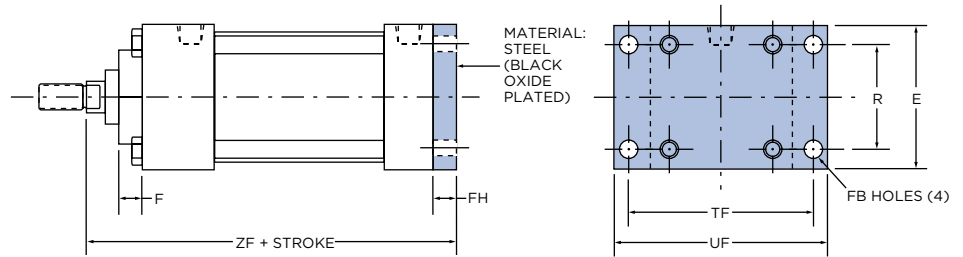

**MODEL DG (NFPA ME3) 8.00" - 12.00" BORES**

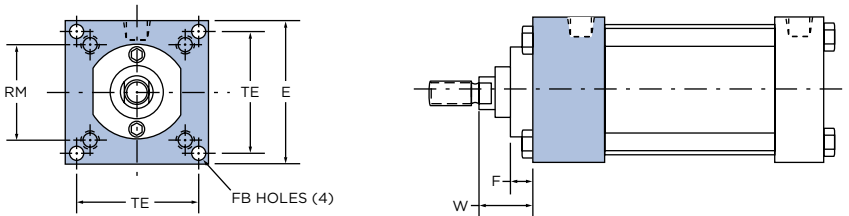

**MODEL CJ (NFPA ME4) 8.00" - 12.00" BORES**

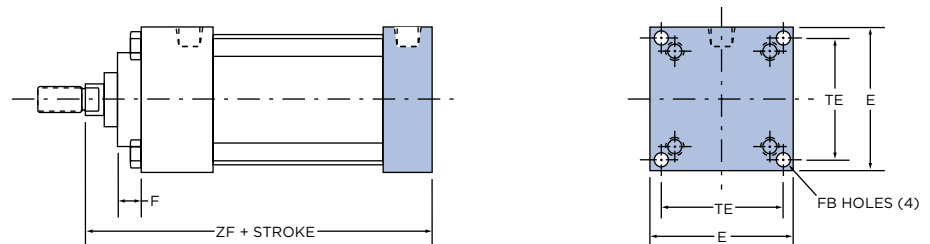

**BASIC DIMENSIONS**

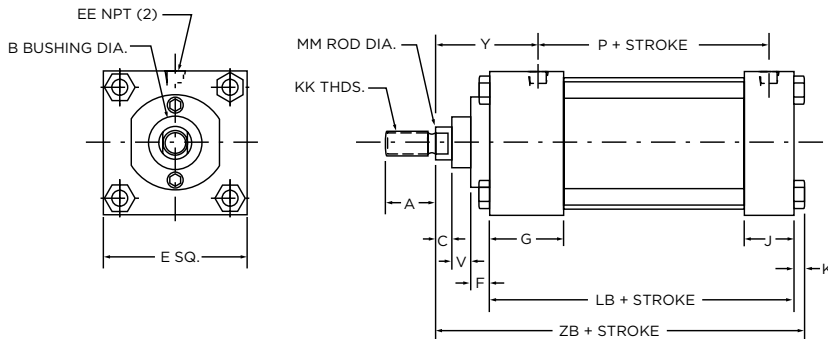

# FLANGE MOUNT CYLINDERS

1.50" THROUGH 12.00" BORE

**Table 1** BASIC DIMENSIONS STANDARD & OVERSIZE RODS

BORE	ROD DIAMETER	A	B	C	EE	G	J	K	KK	LB	MM	P	V	Y	ZB
1.50	0.63	0.750	1.125	0.375	0.375	1.500	1.000	0.250	7/16-20	3.625	0.625	2.375	0.250	1.875	4.875
	1.00	1.125	1.500	0.500	0.375	1.500	1.000	0.250	3/4-16	3.625	1.000	2.375	0.500	2.250	5.250
2.00	0.63	0.750	1.125	0.375	0.375	1.500	1.000	0.313	3/4-20	3.625	0.625	2.375	0.250	1.875	4.938
	1.00	1.125	1.500	0.500	0.375	1.500	1.000	0.313	3/4-16	3.625	1.000	2.375	0.500	2.250	5.313
2.50	0.63	0.750	1.125	0.375	0.375	1.500	1.000	0.313	7/16-20	3.750	0.625	2.500	0.250	1.875	5.063
	1.00	1.125	1.500	0.500	0.375	1.500	1.000	0.313	3/4-16	3.750	1.000	2.500	0.500	2.250	5.438
3.25	1.00	1.125	1.500	0.500	0.500	1.750	1.250	0.375	3/4-16	4.250	1.000	2.750	0.250	2.375	6.000
	1.38	1.625	2.000	0.625	0.500	1.750	1.250	0.375	1-14	4.250	1.000	1.375	0.375	2.625	6.250
4.00	1.00	1.125	1.500	0.500	0.500	1.750	1.250	0.375	3/4-16	4.250	1.000	2.750	0.250	2.375	6.000
	1.38	1.625	2.000	0.625	0.500	1.750	1.250	0.375	1-14	4.250	1.000	1.375	0.375	2.625	6.250
5.00	1.00	1.125	1.500	0.500	0.500	1.750	1.250	0.438	3/4-16	4.500	1.000	3.000	0.250	2.375	6.313
	1.38	1.625	2.000	0.625	0.500	1.750	1.250	0.438	1-14	4.500	1.000	1.375	0.375	2.625	6.563
6.00	1.38	1.625	2.000	0.625	0.750	2.000	1.500	0.438	1-14	5.000	1.375	3.250	0.375	2.750	7.063
	1.75	2.000	2.375	0.750	0.750	2.000	1.500	0.438	1-1/4-12	5.000	1.750	3.250	0.500	3.000	7.313
8.00	1.38	1.625	2.000	0.625	0.750	2.000	1.500	0.563	1-14	5.125	1.375	3.375	0.375	2.750	7.313
	1.75	2.000	2.375	0.750	0.750	2.000	1.500	0.563	1-1/4-12	5.125	1.750	3.375	0.500	3.000	7.563
10.00	1.75	2.000	2.375	0.750	1.000	2.250	2.000	0.688	1-1/4-12	6.375	1.750	4.313	0.500	3.063	8.938
	2.00	2.250	2.625	0.875	1.000	2.250	2.000	0.688	1-1/2-12	6.375	2.000	4.313	0.375	3.188	9.063
12.00	2.00	2.250	2.625	0.875	1.000	2.250	2.000	0.688	1-1/2-12	6.875	2.000	4.813	0.375	3.188	9.563
	2.50	3.000	3.125	1.000	1.000	2.250	2.000	0.688	1-7/8-12	6.875	2.500	4.813	0.500	3.438	9.813

**Table 2** MODELS D, C, DG AND CJ FLANGE MOUNT DIMENSIONS

BORE	ROD DIAMETER	E	F	FB	FH	R	RM	TE	TF	UF	W	ZF
1.50	0.63	2.000	0.375	0.313	0.375	1.438	-	-	2.750	3.375	0.625	5.000
	1.00	2.000	0.375	0.313	0.375	1.438	-	-	2.750	3.375	1.000	5.375
2.00	0.63	2.500	0.375	0.375	0.375	1.848	-	-	3.375	4.125	0.625	5.000
	1.00	2.500	0.375	0.375	0.375	1.848	-	-	3.375	4.125	1.000	5.375
2.50	0.63	3.000	0.375	0.375	0.375	2.188	-	-	3.875	4.625	0.625	5.125
	1.00	3.000	0.375	0.375	0.375	2.188	-	-	3.875	4.625	1.000	5.500
3.25	1.00	3.750	0.625	0.438	0.625	2.766	-	-	4.688	5.500	0.750	6.250
	1.38	3.750	0.625	0.438	0.625	2.766	-	-	4.688	5.500	1.000	6.500
4.00	1.00	4.500	0.625	0.438	0.625	3.328	-	-	5.438	6.250	0.750	6.250
	1.38	4.500	0.625	0.438	0.625	3.328	-	-	5.438	6.250	1.000	6.500
5.00	1.00	5.500	0.625	0.563	0.625	4.100	-	-	6.625	7.625	0.750	6.500
	1.38	5.500	0.625	0.563	0.625	4.100	-	-	6.625	7.625	1.000	6.750
6.00	1.38	6.500	0.625	0.563	0.750	4.875	-	-	7.625	8.625	0.875	7.375
	1.75	6.500	0.625	0.563	0.750	4.875	-	-	7.625	8.625	1.125	7.625
8.00	1.38	8.500	0.625	0.688	N/A	N/A	3.500	7.570	N/A	N/A	1.625	6.750
	1.75	8.500	0.625	0.688	N/A	N/A	3.500	7.570	N/A	N/A	1.875	7.000
10.00	1.75	10.625	0.625	0.813	N/A	N/A	3.500	9.400	N/A	N/A	1.875	8.250
	2.00	10.625	0.750	0.813	N/A	N/A	5.000	9.400	N/A	N/A	2.000	8.375
12.00	2.00	12.750	0.750	0.813	N/A	N/A	5.000	11.100	N/A	N/A	2.000	8.875
	2.50	12.750	0.750	0.813	N/A	N/A	5.000	11.100	N/A	N/A	2.250	9.125

### MODEL E (NFPA MP1)

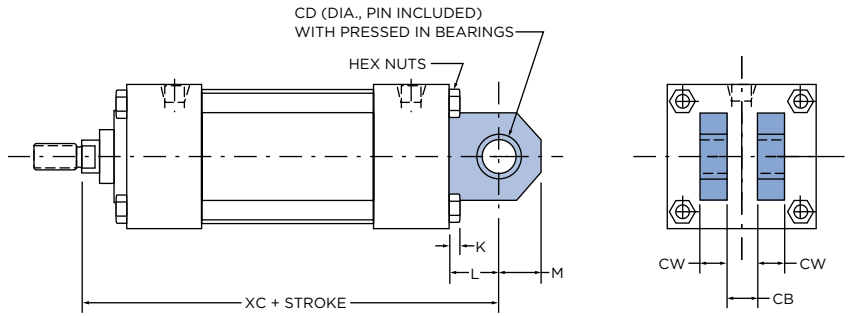

### MODEL HE (NFPA MP2) 1.50" - 6.00" BORES

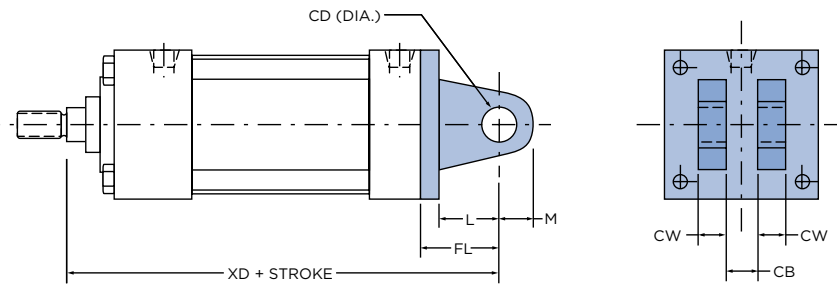

### MODEL E4 (NFPA MP4) 1.50" - 6.00" BORES

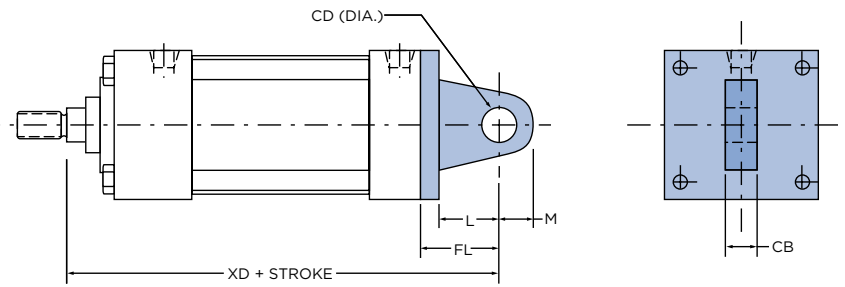

### BASIC DIMENSIONS

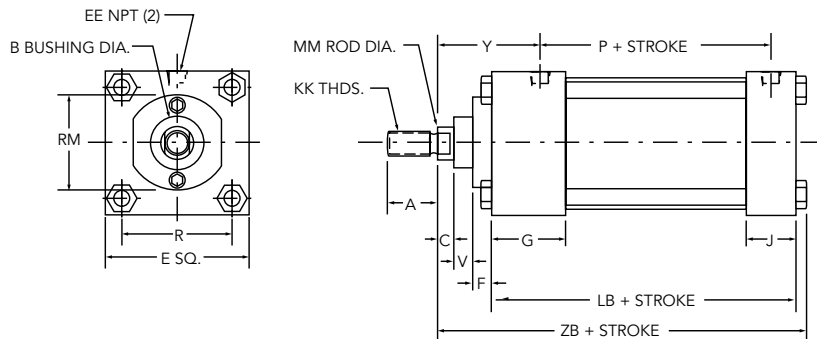

# CLEVIS AND EYE MOUNT CYLINDERS

1.50" THROUGH 12.00" BORE

**Table 1** BASIC DIMENSIONS STANDARD & OVERSIZE RODS

BORE	ROD DIAMETER	A	B	C	E	EE	F	G	J	KK	LB	MM	P	R	RM	V	Y	ZB
1.50	0.63	0.750	1.125	0.375	2.000	0.375	0.375	1.500	1.000	7/16-20	3.625	0.625	2.375	1.438	2.00	0.250	1.875	4.875
	1.00	1.125	1.500	0.500	2.000	0.375	0.375	1.500	1.000	3/4-16	3.625	1.000	2.375	1.438	2.00	0.500	2.250	5.250
2.00	0.63	0.750	1.125	0.375	2.500	0.375	0.375	1.500	1.000	3/4-20	3.625	0.625	2.375	1.844	2.00	0.250	1.875	4.938
	1.00	1.125	1.500	0.500	2.500	0.375	0.375	1.500	1.000	3/4-16	3.625	1.000	2.375	1.844	2.50	0.500	2.250	5.313
2.50	0.63	0.750	1.125	0.375	3.000	0.375	0.375	1.500	1.000	7/16-20	3.750	0.625	2.500	2.188	2.00	0.250	1.875	5.063
	1.00	1.125	1.500	0.500	3.000	0.375	0.375	1.500	1.000	3/4-16	3.750	1.000	2.500	2.188	3.00	0.500	2.250	5.438
3.25	1.00	1.125	1.500	0.500	3.750	0.500	0.625	1.750	1.250	3/4-16	4.250	1.000	2.750	2.766	2.75	0.250	2.375	6.000
	1.38	1.625	2.000	0.625	3.750	0.500	0.625	1.750	1.250	1-14	4.250	1.000	1.375	2.766	3.75	0.375	2.625	6.250
4.00	1.00	1.125	1.500	0.500	4.500	0.500	0.625	1.750	1.250	3/4-16	4.250	1.000	2.750	3.320	2.75	0.250	2.375	6.000
	1.38	1.625	2.000	0.625	4.500	0.500	0.625	1.750	1.250	1-14	4.250	1.000	1.375	3.320	3.50	0.375	2.625	6.250
5.00	1.00	1.125	1.500	0.500	5.500	0.500	0.625	1.750	1.250	3/4-16	4.500	1.000	3.000	4.100	2.75	0.250	2.375	6.313
	1.38	1.625	2.000	0.625	5.500	0.500	0.625	1.750	1.250	1-14	4.500	1.000	1.375	4.100	3.50	0.375	2.625	6.563
6.00	1.38	1.625	2.000	0.625	6.500	0.750	0.625	2.000	1.500	1-14	5.000	1.375	3.250	4.875	3.50	0.375	2.750	7.063
	1.75	2.000	2.375	0.750	6.500	0.750	0.625	2.000	1.500	1-1/4-12	5.000	1.750	3.250	4.875	3.50	0.500	3.000	7.313
8.00	1.38	1.625	2.000	0.625	8.500	0.750	0.625	2.000	1.500	1-14	5.125	1.375	3.375	6.438	3.50	0.375	2.750	7.313
	1.75	2.000	2.375	0.750	8.500	0.750	0.625	2.000	1.500	1-1/4-12	5.125	1.750	3.375	6.438	3.50	0.500	3.000	7.563
10.00	1.75	2.000	2.375	0.750	10.625	1.000	0.625	2.250	2.000	1-1/4-12	6.375	1.750	4.313	7.922	3.50	0.500	3.063	8.938
	2.00	2.250	2.625	0.875	10.625	1.000	0.750	2.250	2.000	1-1/2-12	6.375	2.000	4.313	7.922	5.00	0.375	3.188	9.063
12.00	2.00	2.250	2.625	0.875	12.750	1.000	0.750	2.250	2.000	1-1/2-12	6.875	2.000	4.813	9.400	5.00	0.375	3.188	9.563
	2.50	3.000	3.125	1.000	12.750	1.000	0.750	2.250	2.000	1-7/8-12	6.875	2.500	4.813	9.400	5.00	0.500	3.438	9.813

**Table 2** MODEL E, HE CLEVIS MOUNT AND MODEL E4 EYE MOUNT DIMENSIONS

BORE	ROD DIAMETER	CB	CD	CW	FL	K	L	M	XC	XD
1.50	0.63	0.750	0.500	0.500	1.125	N/A	0.750	0.625	5.375	5.750
	1.00	0.750	0.500	0.500	1.125	N/A	0.750	0.625	5.750	6.125
2.00	0.63	0.750	0.500	0.500	1.125	N/A	0.750	0.625	5.375	5.750
	1.00	0.750	0.500	0.500	1.125	N/A	0.750	0.625	5.750	6.125
2.50	0.63	0.750	0.500	0.500	1.125	N/A	0.750	0.625	5.500	5.875
	1.00	0.750	0.500	0.500	1.125	N/A	0.750	0.625	5.875	6.250
3.25	1.00	1.250	0.750	0.625	1.875	0.375	1.250	0.875	6.875	7.500
	1.38	1.250	0.750	0.625	1.875	0.375	1.250	0.875	7.125	7.750
4.00	1.00	1.250	0.750	0.625	1.875	0.375	1.250	0.875	6.875	7.500
	1.38	1.250	0.750	0.625	1.875	0.375	1.250	0.875	7.125	7.750
5.00	1.00	1.250	0.750	0.625	1.875	0.438	1.250	0.875	7.125	7.750
	1.38	1.250	0.750	0.625	1.875	0.438	1.250	0.875	7.375	8.000
6.00	1.38	1.500	1.000	0.750	2.250	0.438	1.500	1.000	8.125	8.875
	1.75	1.500	1.000	0.750	2.250	0.438	1.500	1.000	8.375	9.125
8.00	1.38	1.500	1.000	0.750	N/A	0.563	1.500	1.000	8.250	N/A
	1.75	1.500	1.000	0.750	N/A	0.563	1.500	1.000	8.500	N/A
10.00	1.75	2.000	1.375	1.000	N/A	0.688	2.125	1.375	10.375	N/A
	2.00	2.000	1.375	1.000	N/A	0.688	2.125	1.375	10.500	N/A
12.00	2.00	2.500	1.750	1.250	N/A	0.688	2.250	1.750	11.125	N/A
	2.50	2.500	1.750	1.250	N/A	0.688	2.250	1.750	11.375	N/A

Clevis pins are provided with pivot mounts.

**MODEL AP (NFPA MS1) 1.50"- 8.00" BORES**

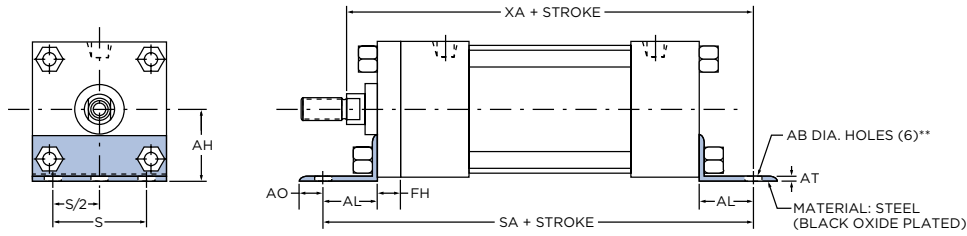

**MODEL A (NFPA MS2) 1.50"- 8.00" BORES**

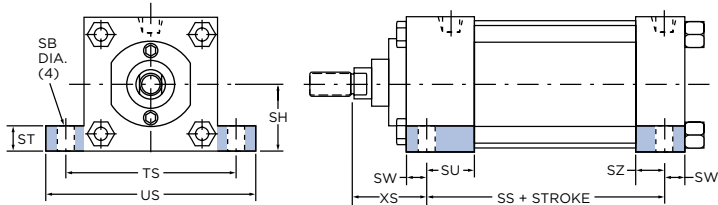

**MODEL S (NFPA MS4)**

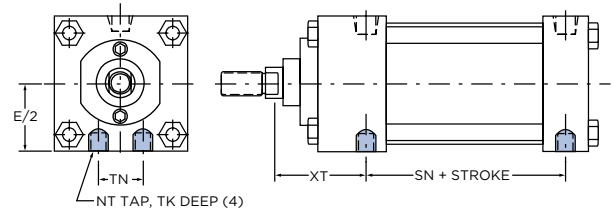

**MODEL H (NO MOUNT)**

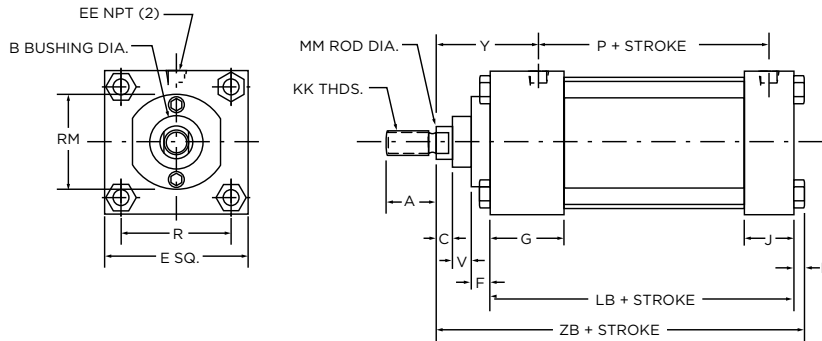

**Table 1** BASIC DIMENSIONS STANDARD & OVERSIZE RODS

BORE	ROD DIAMETER	A	B	C	E	EE	F	G	J	K	KK	LB	MM	P	R	RM	V	Y	ZB
1.50	0.63	0.750	1.125	0.375	2.000	0.375	0.375	1.500	1.000	0.250	7/16-20	3.625	0.625	2.375	1.438	2.00	0.250	1.875	4.875
	1.00	1.125	1.500	0.500	2.000	0.375	0.375	1.500	1.000	0.250	3/4-16	3.625	1.000	2.375	1.438	2.00	0.500	2.250	5.250
2.00	0.63	0.750	1.125	0.375	2.500	0.375	0.375	1.500	1.000	0.313	3/4-20	3.625	0.625	2.375	1.844	2.00	0.250	1.875	4.938
	1.00	1.125	1.500	0.500	2.500	0.375	0.375	1.500	1.000	0.313	3/4-16	3.625	1.000	2.375	1.844	2.50	0.500	2.250	5.313
2.50	0.63	0.750	1.125	0.375	3.000	0.375	0.375	1.500	1.000	0.313	7/16-20	3.750	0.625	2.500	2.188	2.00	0.250	1.875	5.063
	1.00	1.125	1.500	0.500	3.000	0.375	0.375	1.500	1.000	0.313	3/4-16	3.750	1.000	2.500	2.188	3.00	0.500	2.250	5.438
3.25	1.00	1.125	1.500	0.500	3.750	0.500	0.625	1.750	1.250	0.375	3/4-16	4.250	1.000	2.750	2.766	2.75	0.250	2.375	6.000
	1.38	1.625	2.000	0.625	3.750	0.500	0.625	1.750	1.250	0.375	1-14	4.250	1.000	1.375	2.766	3.75	0.375	2.625	6.250
4.00	1.00	1.125	1.500	0.500	4.500	0.500	0.625	1.750	1.250	0.375	3/4-16	4.250	1.000	2.750	3.320	2.75	0.250	2.375	6.000
	1.38	1.625	2.000	0.625	4.500	0.500	0.625	1.750	1.250	0.375	1-14	4.250	1.000	1.375	3.320	3.50	0.375	2.625	6.250
5.00	1.00	1.125	1.500	0.500	5.500	0.500	0.625	1.750	1.250	0.438	3/4-16	4.500	1.000	3.000	4.100	2.75	0.250	2.375	6.313
	1.38	1.625	2.000	0.625	5.500	0.500	0.625	1.750	1.250	0.438	1-14	4.500	1.000	1.375	4.100	3.50	0.375	2.625	6.563
6.00	1.38	1.625	2.000	0.625	6.500	0.750	0.625	2.000	1.500	0.438	1-14	5.000	1.375	3.250	4.875	3.50	0.375	2.750	7.063
	1.75	2.000	2.375	0.750	6.500	0.750	0.625	2.000	1.500	0.438	1-1/4-12	5.000	1.750	3.250	4.875	3.50	0.500	3.000	7.313
8.00	1.38	1.625	2.000	0.625	8.500	0.750	0.625	2.000	1.500	0.563	1-14	5.125	1.375	3.375	6.438	3.50	0.375	2.750	7.313
	1.75	2.000	2.375	0.750	8.500	0.750	0.625	2.000	1.500	0.563	1-1/4-12	5.125	1.750	3.375	6.438	3.50	0.500	3.000	7.563
10.00	1.75	2.000	2.375	0.750	10.625	1.000	0.625	2.250	2.000	0.688	1-1/4-12	6.375	1.750	4.313	7.922	3.50	0.500	3.063	8.938
	2.00	2.250	2.625	0.875	10.625	1.000	0.750	2.250	2.000	0.688	1-1/2-12	6.375	2.000	4.313	7.922	5.00	0.375	3.188	9.063
12.00	2.00	2.250	2.625	0.875	12.750	1.000	0.750	2.250	2.000	0.688	1-1/2-12	6.875	2.000	4.813	9.400	5.00	0.375	3.188	9.563
	2.50	3.000	3.125	1.000	12.750	1.000	0.750	2.250	2.000	0.688	1-7/8-12	6.875	2.500	4.813	9.400	5.00	0.500	3.438	9.813



# ANGLE AND SIDE LUG MOUNT CYLINDERS

1.50" THROUGH 12.00" BORE

**Table 2** MODEL AP ANGLE BASE MOUNT DIMENSIONS

BORE	ROD DIAMETER	AB	AH	AL	AO	AT	FH	S	SA ADD STROKE	XA ADD STROKE
1.50	0.63	0.438	1.188	1.000	0.375	0.188	0.375	1.250	6.000	5.625
	1.00	0.438	1.188	1.000	0.375	0.188	0.375	1.250	6.000	6.000
2.00	0.63	0.438	1.438	1.000	0.375	0.188	0.375	1.750	6.000	5.625
	1.00	0.438	1.438	1.000	0.375	0.188	0.375	1.750	6.000	6.000
2.50	0.63	0.438	1.625	1.000	0.375	0.188	0.375	2.250	6.125	5.750
	1.00	0.438	1.625	1.000	0.375	0.188	0.375	2.250	6.125	6.125
3.25	1.00	0.563	1.938	1.250	0.500	0.125	0.625	2.750	7.375	6.875
	1.38	0.563	1.938	1.250	0.500	0.125	0.625	2.750	7.375	7.125
4.00	1.00	0.563	2.250	1.250	0.500	0.125	0.625	3.500	7.375	6.875
	1.38	0.563	2.250	1.250	0.500	0.125	0.625	3.500	7.375	7.125
5.00	1.00	0.688	2.750	1.375	0.625	0.188	0.625	4.250	7.875	7.250
	1.38	0.688	2.750	1.375	0.625	0.188	0.625	4.250	7.875	7.500
6.00	1.38	0.813	3.250	1.375	0.625	0.188	0.750	5.250	8.500	8.000
	1.75	0.813	3.250	1.375	0.625	0.188	0.750	5.250	8.500	8.250
8.00	1.38	0.813	4.250	1.813	0.688	0.250	0.625*	7.125	8.750	8.563
	1.75	0.813	4.250	1.813	0.688	0.250	0.625*	7.125	8.750	8.813

\* 3.50" diameter round retainer on 8.00" bore (AP BRACKET BOLTED DIRECTLY TO HEAD). \*\* 1.50" bore has four (4) AB diameter holes.

**Table 3** MODEL A SIDE LUG BASE MOUNT DIMENSIONS

BORE	ROD DIAMETER	SB	SH	ST	SU	SW	SZ	TS	US	XS	SS ADD STROKE
1.50	0.63	0.438	1.000	0.500	1.125	0.375	0.625	2.750	3.500	1.375	2.875
	1.00	0.438	1.000	0.500	1.125	0.375	0.625	2.750	3.500	1.750	2.875
2.00	0.63	0.438	1.250	0.500	1.125	0.375	0.625	3.250	4.000	1.375	2.875
	1.00	0.438	1.250	0.500	1.125	0.375	0.625	3.250	4.000	1.750	2.875
2.50	0.63	0.438	1.500	0.500	1.125	0.375	0.625	3.750	4.500	1.375	3.000
	1.00	0.438	1.500	0.500	1.125	0.375	0.625	3.750	4.500	1.750	3.000
3.25	1.00	0.563	1.875	0.750	1.250	0.500	0.750	4.750	5.750	1.875	3.250
	1.38	0.563	1.875	0.750	1.250	0.500	0.750	4.750	5.750	2.125	3.250
4.00	1.00	0.563	2.250	0.750	1.250	0.500	0.750	5.500	6.500	1.875	3.250
	1.38	0.563	2.250	0.750	1.250	0.500	0.750	5.500	6.500	2.125	3.250
5.00	1.00	0.813	2.750	1.000	1.063	0.688	0.563	6.875	8.250	2.063	3.125
	1.38	0.813	2.750	1.000	1.063	0.688	0.563	6.875	8.250	2.313	3.125
6.00	1.38	0.813	3.250	1.000	1.313	0.688	0.813	7.875	9.250	2.313	3.625
	1.75	0.813	3.250	1.000	1.313	0.688	0.813	7.875	9.250	2.563	3.625
8.00	1.38	0.813	4.250	1.000	1.313	0.688	0.813	9.875	11.250	2.313	3.750
	1.75	0.813	4.250	1.000	1.313	0.688	0.813	9.875	11.250	2.563	3.750

**Table 4** MODEL S BOTTOM TAPPED BASE MOUNT DIMENSIONS

BORE	ROD DIAMETER	E/2	NT	TK	TN	XT	SN ADD STROKE
1.50	0.63	1.000	1/4-20	0.375	0.625	1.938	2.250
	1.00	1.000	1/4-20	0.375	0.625	2.313	2.250
2.00	0.63	1.250	5/16-18	0.500	0.875	1.938	2.250
	1.00	1.250	5/16-18	0.500	0.875	2.313	2.250
2.50	0.63	1.500	3/8-16	0.625	1.250	1.938	2.3875
	1.00	1.500	3/8-16	0.625	1.250	2.313	2.3875
3.25	1.00	1.875	1/2-13	0.750	1.500	2.438	2.625
	1.38	1.875	1/2-13	0.750	1.500	2.688	2.625
4.00	1.00	2.250	1/2-13	0.750	2.063	2.438	2.625
	1.38	2.250	1/2-13	0.750	2.063	2.688	2.625
5.00	1.00	2.750	5/8-11	1.000	2.688	2.438	2.875
	1.38	2.750	5/8-11	1.000	2.688	2.688	2.875
6.00	1.38	3.250	3/4-10	1.125	3.250	2.813	3.125
	1.75	3.250	3/4-10	1.125	3.250	3.063	3.125
8.00	1.38	4.250	3/4-10	1.125	4.500	2.813	3.250
	1.75	4.250	3/4-10	1.125	4.500	3.063	3.250
10.00	1.75	5.313	1-8	1.500	5.500	3.125	4.125
	2.00	5.313	1-8	1.500	5.500	3.250	4.125
12.00	2.00	6.375	1-8	1.500	7.250	3.250	4.625
	2.50	6.375	1-8	1.500	7.250	3.500	4.625

### MODEL FR (NFPA MT1)

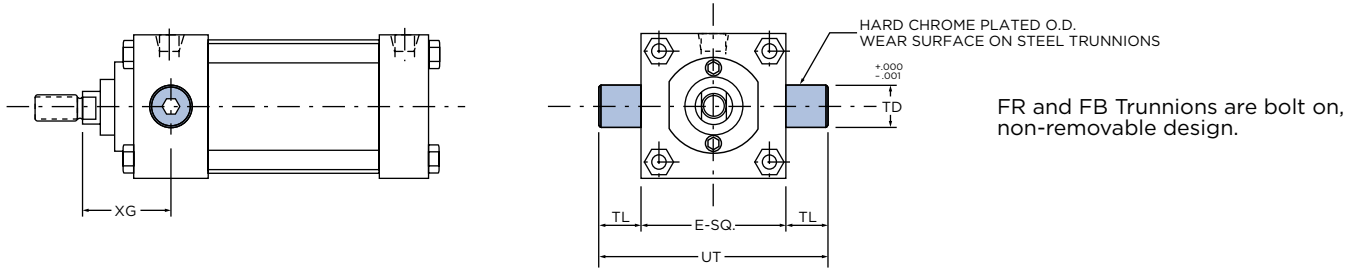

### MODEL FB (NFPA MT2)

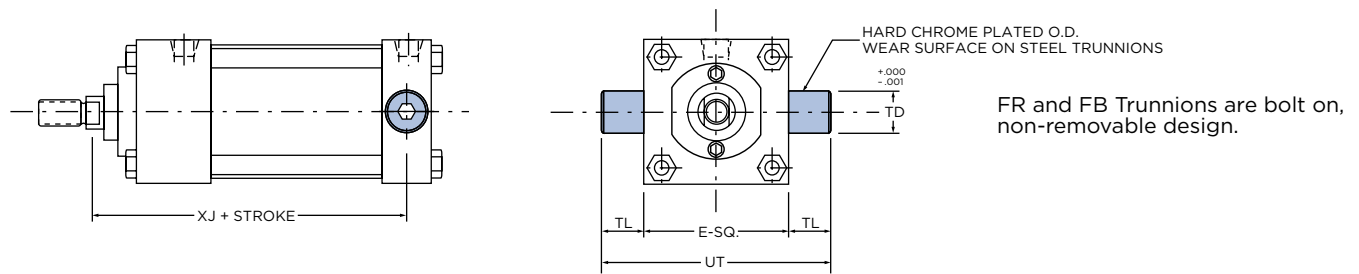

### MODEL F (NFPA MT4)

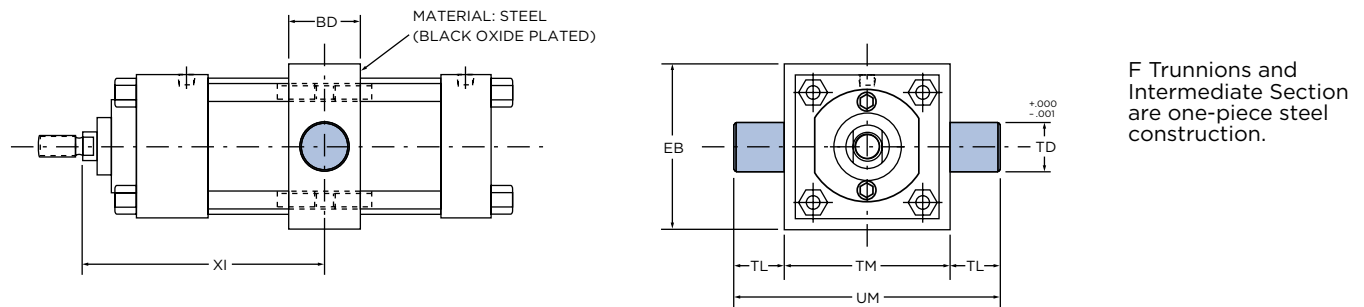

### BASIC DIMENSIONS

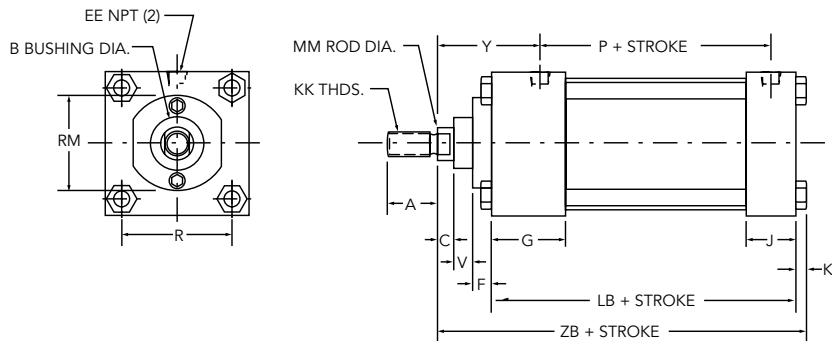

# TRUNNION MOUNT CYLINDERS

1.50" THROUGH 8.00" BORE

**Table 1** BASIC DIMENSIONS STANDARD & OVERSIZE RODS

BORE	ROD DIAMETER	A	B	C	EE	F	G	J	K	KK	LB	MM	P	R	RM	V	Y	ZB
1.50	0.63	0.750	1.125	0.375	0.375	0.375	1.500	1.000	0.250	7/16-20	3.625	0.625	2.375	1.438	2.00	0.250	1.875	4.875
	1.00	1.125	1.500	0.500	0.375	0.375	1.500	1.000	0.250	3/4-16	3.625	1.000	2.375	1.438	2.00	0.500	2.250	5.250
2.00	0.63	0.750	1.125	0.375	0.375	0.375	1.500	1.000	0.313	3/4-20	3.625	0.625	2.375	1.844	2.00	0.250	1.875	4.938
	1.00	1.125	1.500	0.500	0.375	0.375	1.500	1.000	0.313	3/4-16	3.625	1.000	2.375	1.844	2.50	0.500	2.250	5.313
2.50	0.63	0.750	1.125	0.375	0.375	0.375	1.500	1.000	0.313	7/16-20	3.750	0.625	2.500	2.188	2.00	0.250	1.875	5.063
	1.00	1.125	1.500	0.500	0.375	0.375	1.500	1.000	0.313	3/4-16	3.750	1.000	2.500	2.188	3.00	0.500	2.250	5.438
3.25	1.00	1.125	1.500	0.500	0.500	0.625	1.750	1.250	0.375	3/4-16	4.250	1.000	2.750	2.766	2.75	0.250	2.375	6.000
	1.38	1.625	2.000	0.625	0.500	0.625	1.750	1.250	0.375	1-14	4.250	1.000	1.375	2.766	3.75	0.375	2.625	6.250
4.00	1.00	1.125	1.500	0.500	0.500	0.625	1.750	1.250	0.375	3/4-16	4.250	1.000	2.750	3.320	2.75	0.250	2.375	6.000
	1.38	1.625	2.000	0.625	0.500	0.625	1.750	1.250	0.375	1-14	4.250	1.000	1.375	3.320	3.50	0.375	2.625	6.250
5.00	1.00	1.125	1.500	0.500	0.500	0.625	1.750	1.250	0.438	3/4-16	4.500	1.000	3.000	4.100	2.75	0.250	2.375	6.313
	1.38	1.625	2.000	0.625	0.500	0.625	1.750	1.250	0.438	1-14	4.500	1.000	1.375	4.100	3.50	0.375	2.625	6.563
6.00	1.38	1.625	2.000	0.625	0.750	0.625	2.000	1.500	0.438	1-14	5.000	1.375	3.250	4.875	3.50	0.375	2.750	7.063
	1.75	2.000	2.375	0.750	0.750	0.625	2.000	1.500	0.438	1-1/4-12	5.000	1.750	3.250	4.875	3.50	0.500	3.000	7.313
8.00	1.38	1.625	2.000	0.625	0.750	0.625	2.000	1.500	0.563	1-14	5.125	1.375	3.375	6.438	3.50	0.375	2.750	7.313
	1.75	2.000	2.375	0.750	0.750	0.625	2.000	1.500	0.563	1-1/4-12	5.125	1.750	3.375	6.438	3.50	0.500	3.000	7.563

**Table 2** MODEL FR HEAD TRUNNION MOUNT AND MODEL FB CAP TRUNNION MOUNT DIMENSIONS

BORE	ROD DIAMETER	E	TD	TL	UT	XG	XJ ADD STROKE
1.50	0.63	2.000	1.000	1.000	4.000	1.750	4.125
	1.00	2.000	1.000	1.000	4.000	N/A*	4.500
2.00	0.63	2.500	1.000	1.000	4.500	1.750	4.125
	1.00	2.500	1.000	1.000	4.500	2.125	4.500
2.50	0.63	3.000	1.000	1.000	5.000	1.750	4.250
	1.00	3.000	1.000	1.000	5.000	2.125	4.625
3.25	1.00	3.750	1.000	1.000	5.750	2.250	5.000
	1.38	3.750	1.000	1.000	5.750	2.500	5.250
4.00	1.00	4.500	1.000	1.000	6.500	2.250	5.000
	1.38	4.500	1.000	1.000	6.500	2.500	5.250
5.00	1.00	5.500	1.000	1.000	7.500	2.250	5.250
	1.38	5.500	1.000	1.000	7.500	2.500	5.500
6.00	1.38	6.500	1.375	1.375	9.250	2.625	5.875
	1.75	6.500	1.375	1.375	9.250	2.875	6.125
8.00	1.38	8.500	1.375	1.375	11.250	2.625	6.000
	1.75	8.500	1.375	1.375	11.250	2.875	6.250

\* No oversize rod available on 1.50" bore Model FR.

**Table 3** MODEL F INTERMEDIATE TRUNNION MOUNT DIMENSIONS

BORE	BD	EB	TD	TL	TM	UM	XI
1.50	1.250	2.500	1.000	1.000	2.500	4.500	Customer to Specify
2.00	1.500	3.000	1.000	1.000	3.000	5.000	
2.50	1.500	3.500	1.000	1.000	3.500	5.500	
3.25	2.000	4.250	1.000	1.000	4.500	6.500	
4.00	2.000	5.000	1.000	1.000	5.250	7.250	
5.00	2.000	6.000	1.000	1.000	6.250	8.250	
6.00	2.000	7.000	1.375	1.375	7.625	10.375	
8.00	2.500	9.500	1.375	1.375	9.750	12.500	

**Table 4** MODELS FR, FB AND F STANDARD CUSHION LOCATIONS

MOUNT	HEAD CUSHION	CAP CUSHION
FR	3	2
FB	2	3
F	2	2

Ports or cushions cannot be on same side as FR & FB Trunnions.

**MODEL T (NFPA MX1)**

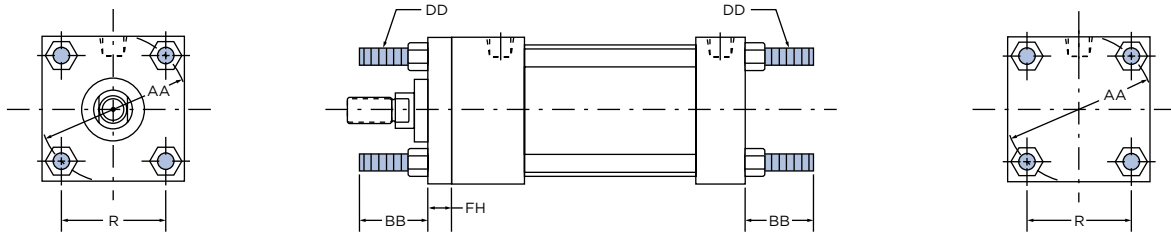

**MODEL TB (NFPA MX2)**

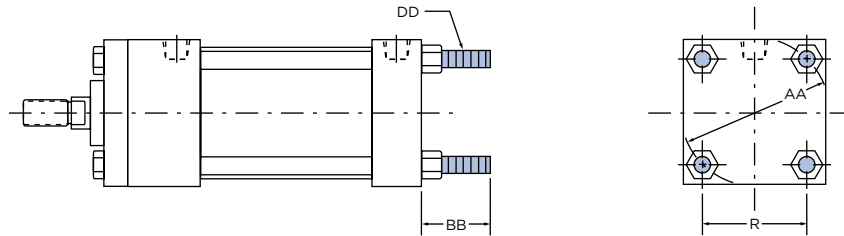

**MODEL TR (NFPA MX3)**

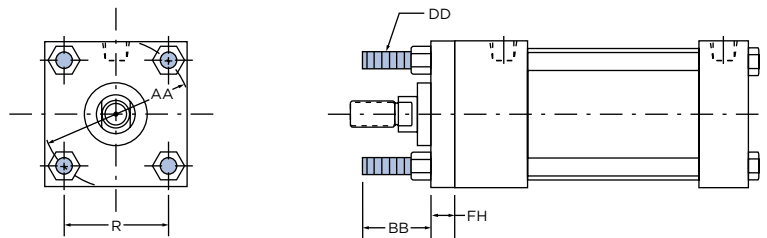

**BASIC DIMENSIONS**

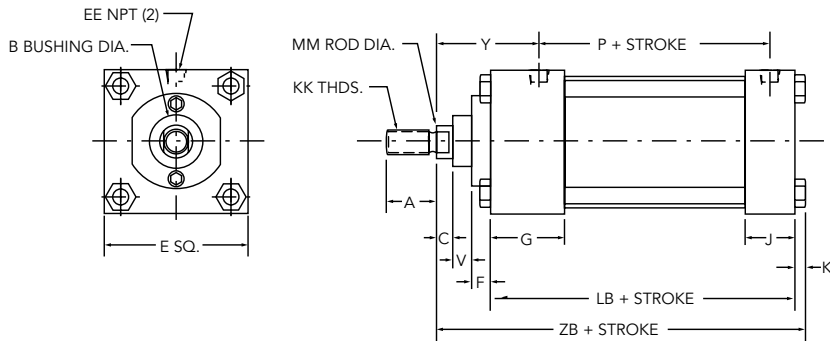

# TIE ROD MOUNT CYLINDERS

1.50" THROUGH 12.00" BORE

**Table 1** BASIC DIMENSIONS STANDARD & OVERSIZE RODS

BORE	ROD DIAMETER	A	B	C	E	EE	F	G	J	K	KK	LB	MM	P	RM	V	Y	ZB
1.50	0.63	0.750	1.125	0.375	2.000	0.375	0.375	1.500	1.000	0.250	7/16-20	3.625	0.625	2.375	2.00	0.250	1.875	4.875
	1.00	1.125	1.500	0.500	2.000	0.375	0.375	1.500	1.000	0.250	3/4-16	3.625	1.000	2.375	2.00	0.500	2.250	5.250
2.00	0.63	0.750	1.125	0.375	2.500	0.375	0.375	1.500	1.000	0.313	3/4-20	3.625	0.625	2.375	2.00	0.250	1.875	4.938
	1.00	1.125	1.500	0.500	2.500	0.375	0.375	1.500	1.000	0.313	3/4-16	3.625	1.000	2.375	2.50	0.500	2.250	5.313
2.50	0.63	0.750	1.125	0.375	3.000	0.375	0.375	1.500	1.000	0.313	7/16-20	3.750	0.625	2.500	2.00	0.250	1.875	5.063
	1.00	1.125	1.500	0.500	3.000	0.375	0.375	1.500	1.000	0.313	3/4-16	3.750	1.000	2.500	3.00	0.500	2.250	5.438
3.25	1.00	1.125	1.500	0.500	3.750	0.500	0.625	1.750	1.250	0.375	3/4-16	4.250	1.000	2.750	2.75	0.250	2.375	6.000
	1.38	1.625	2.000	0.625	3.750	0.500	0.625	1.750	1.250	0.375	1-14	4.250	1.000	1.375	3.75	0.375	2.625	6.250
4.00	1.00	1.125	1.500	0.500	4.500	0.500	0.625	1.750	1.250	0.375	3/4-16	4.250	1.000	2.750	2.75	0.250	2.375	6.000
	1.38	1.625	2.000	0.625	4.500	0.500	0.625	1.750	1.250	0.375	1-14	4.250	1.000	1.375	3.50	0.375	2.625	6.250
5.00	1.00	1.125	1.500	0.500	5.500	0.500	0.625	1.750	1.250	0.438	3/4-16	4.500	1.000	3.000	2.75	0.250	2.375	6.313
	1.38	1.625	2.000	0.625	5.500	0.500	0.625	1.750	1.250	0.438	1-14	4.500	1.000	1.375	3.50	0.375	2.625	6.563
6.00	1.38	1.625	2.000	0.625	6.500	0.750	0.625	2.000	1.500	0.438	1-14	5.000	1.375	3.250	3.50	0.375	2.750	7.063
	1.75	2.000	2.375	0.750	6.500	0.750	0.625	2.000	1.500	0.438	1-1/4-12	5.000	1.750	3.250	3.50	0.500	3.000	7.313
8.00	1.38	1.625	2.000	0.625	8.500	0.750	0.625	2.000	1.500	0.563	1-14	5.125	1.375	3.375	3.50	0.375	2.750	7.313
	1.75	2.000	2.375	0.750	8.500	0.750	0.625	2.000	1.500	0.563	1-1/4-12	5.125	1.750	3.375	3.50	0.500	3.000	7.563
10.00	1.75	2.000	2.375	0.750	10.625	1.000	0.625	2.250	2.000	0.688	1-1/4-12	6.375	1.750	4.313	3.50	0.500	3.063	8.938
	2.00	2.250	2.625	0.875	10.625	1.000	0.750	2.250	2.000	0.688	1-1/2-12	6.375	2.000	4.313	5.00	0.375	3.188	9.063
12.00	2.00	2.250	2.625	0.875	12.750	1.000	0.750	2.250	2.000	0.688	1-1/2-12	6.875	2.000	4.813	5.00	0.375	3.188	9.563
	2.50	3.000	3.125	1.000	12.750	1.000	0.750	2.250	2.000	0.688	1-7/8-12	6.875	2.500	4.813	5.00	0.500	3.438	9.813

**Table 2** MODELS T, TB AND TR TIE ROD EXTENDED MOUNT DIMENSIONS

BORE	ROD DIAMETER	AA	BB	DD	FH	R
1.50	0.63	2.020	1.000	1/4-28	0.375	1.430
	1.00	2.020	1.000	1/4-28	0.375	1.430
2.00	0.63	2.600	1.125	5/16-24	0.375	1.840
	1.00	2.600	1.125	5/16-24	0.375	1.840
2.50	0.63	3.100	1.125	5/16-24	0.375	2.190
	1.00	3.100	1.125	5/16-24	0.375	2.190
3.25	1.00	3.900	1.375	3/8-24	0.625	2.760
	1.38	3.900	1.375	3/8-24	0.625	2.760
4.00	1.00	4.700	1.375	3/8-24	0.625	3.320
	1.38	4.700	1.375	3/8-24	0.625	3.320
5.00	1.00	5.800	1.813	1/2-20	0.625	4.100
	1.38	5.800	1.813	1/2-20	0.625	4.100
6.00	1.38	6.900	1.813	1/2-20	0.750	4.880
	1.75	6.900	1.813	1/2-20	0.750	4.880
8.00	1.38	9.100	**2.313	5/8-18	*0.625	6.440
	1.75	9.100	**2.313	5/8-18	*0.625	6.440
10.00	1.75	11.200	**2.688	3/4-16	*0.625	7.920
	2.00	11.200	**2.688	3/4-16	*0.750	7.920
12.00	2.00	13.300	**2.688	3/4-16	*0.750	9.400
	2.50	13.300	**2.688	3/4-16	*0.750	9.400

\* T & TR have full square bushing retainer on 1.50"- 6.00" bores, round retainers on 8.00"-12.00" bores.

\*\* BB dimension from face of head.

**DOUBLE ROD END MODELS**

**BENEFITS:**

- Standard and Oversize Piston Rods available.
- Full range of Standard Options.
- Durable design. Full Rod Bearing at each end of cylinder.
- Available in Models A, AP, D, DG, F, FR, S, T and TR.

Double rod end models are designated by letter "X" preceding the model identification.

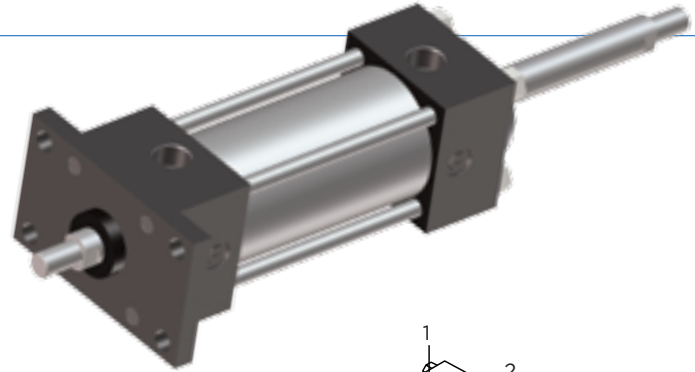

**Standard Port And Cushion Adjustment Positions**

- Ports - Position 1
- Cushion Adjustment - Position 2
- Specify Non-Standard Positions When Ordering

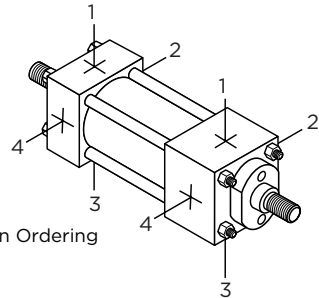

**MODEL XH (NO MOUNT)**

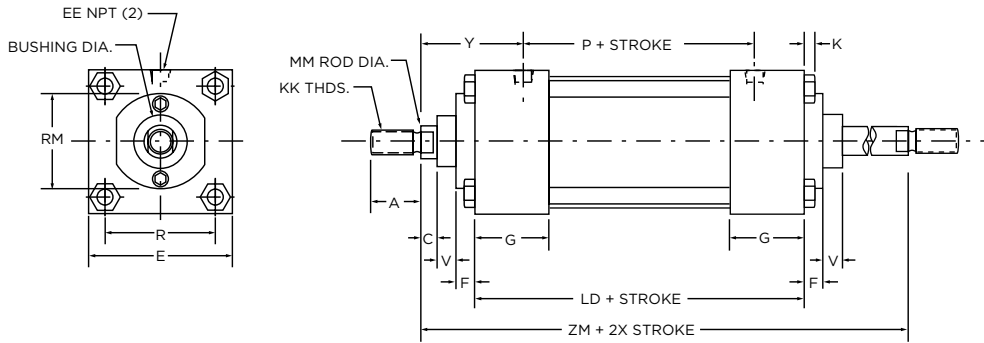

**Table 1** BASIC DIMENSIONS DOUBLE ROD END STANDARD & OVERSIZE RODS

BORE	ROD DIAMETER	A	B	C	E	EE	F	G	K	KK	LD	MM	P	R	RM	V	Y	ZM
1.50	0.63	0.750	1.125	0.375	2.000	0.375	0.375	1.500	0.250	7/16-20	4.125	0.625	2.375	1.430	2.00	0.250	1.875	6.125
	1.00	1.125	1.500	0.500	2.000	0.375	0.375	1.500	0.250	3/4-16	4.125	1.000	2.375	1.430	2.00	0.500	2.250	6.875
2.00	0.63	0.750	1.125	0.375	2.500	0.375	0.375	1.500	0.313	7/16-20	4.125	0.625	2.375	1.844	2.00	0.250	1.875	6.125
	1.00	1.125	1.500	0.500	2.500	0.375	0.375	1.500	0.313	3/4-16	4.125	1.000	2.375	1.844	2.50	0.500	2.250	6.875
2.50	0.63	0.750	1.125	0.375	3.000	0.375	0.375	1.500	0.313	7/16-20	4.250	0.625	2.500	2.188	2.00	0.250	1.875	6.250
	1.00	1.125	1.500	0.500	3.000	0.375	0.375	1.500	0.313	3/4-16	4.250	1.000	2.500	2.188	3.00	0.500	2.250	7.000
3.25	1.00	1.125	1.500	0.500	3.750	0.500	0.625	1.750	0.375	3/4-16	4.750	1.000	2.750	2.760	2.75	0.250	2.375	7.500
	1.38	1.625	2.000	0.625	3.750	0.500	0.625	1.750	0.375	1-14	4.750	1.375	2.750	2.760	3.75	0.375	2.625	8.000
4.00	1.00	1.125	1.500	0.500	4.500	0.500	0.625	1.750	0.375	3/4-16	4.750	1.000	2.750	3.320	2.75	0.250	2.375	7.500
	1.38	1.625	2.000	0.625	4.500	0.500	0.625	1.750	0.375	1-14	4.750	1.375	2.750	3.320	3.50	0.375	2.625	8.000
5.00	1.00	1.125	1.500	0.500	5.500	0.500	0.625	1.750	0.438	3/4-16	5.000	1.000	3.000	4.100	2.75	0.250	2.375	7.750
	1.38	1.625	2.000	0.625	5.500	0.500	0.625	1.750	0.438	1-14	5.000	1.375	3.000	4.100	3.50	0.375	2.625	8.250
6.00	1.38	1.625	2.000	0.625	6.500	0.750	0.625	2.000	0.438	1-14	5.500	1.375	3.250	4.875	3.50	0.375	2.750	8.750
	1.75	2.000	2.375	0.750	6.500	0.750	0.625	2.000	0.438	1-1/4-12	5.500	1.750	3.250	4.875	3.50	0.500	3.000	9.250
8.00	1.38	1.625	2.000	0.625	8.500	0.750	0.625	2.000	0.563	1-14	5.625	1.375	3.375	6.438	3.50	0.375	2.750	8.875
	1.75	2.000	2.375	0.750	8.500	0.750	0.625	2.000	0.563	1-1/4-12	5.625	1.750	3.375	6.438	3.50	0.500	3.000	9.375
10.00	1.75	2.000	2.375	0.750	10.625	1.000	0.625	2.250	0.688	1-1/4-12	6.625	1.750	4.313	7.922	3.50	0.500	3.060	10.375
	2.00	2.250	2.625	0.875	10.625	1.000	0.750	2.250	0.688	1-1/2-12	6.625	2.000	4.313	7.922	5.00	0.375	3.188	10.625
12.00	2.00	2.250	2.625	0.875	12.750	1.000	0.750	2.250	0.688	1-1/2-12	7.125	2.000	4.813	9.400	5.00	0.375	3.188	11.125
	2.50	3.000	3.125	1.000	12.750	1.000	0.750	2.250	0.688	1-7/8-12	7.125	2.500	4.813	9.400	5.00	0.500	3.438	11.625

## BASIC CYLINDER FORCE CHART

BORE	ROD DIA.	STROKE TYPE	EFFECTIVE PISTON AREA	POUNDS OF FORCE AT PSI						CU. FT. DISPLACEMENT PER IN. OF STROKE
				60	80	100	200	250	400	
1.50	ALL	PUSH	1.767	106	142	177	353	442	706	.00102
	0.63	PULL	1.460	88	117	146	292	365	584	.00084
	1.00	PULL	0.982	59	79	98	196	246	392	.00057
2.00	ALL	PUSH	3.142	188	251	314	628	785	1256	.00182
	0.63	PULL	2.835	170	227	284	567	708	1134	.00164
	1.00	PULL	2.357	141	189	236	471	589	942	.00136
2.50	ALL	PUSH	4.909	295	393	491	981	1227	1962	.00284
	0.63	PULL	4.602	276	368	460	920	1150	1840	.00266
	1.00	PULL	4.124	247	330	412	825	1031	1650	.00239
3.25	ALL	PUSH	8.296	498	664	830	1659	2074	3318	.00480
	1.00	PULL	7.511	451	601	751	1502	1877	3004	.00435
	1.38	PULL	6.811	409	545	681	1362	1702	2724	.00394
4.00	ALL	PUSH	12.566	754	1005	1257	2513	3141	5026	.00727
	1.00	PULL	11.781	707	942	1178	2356	2945	4712	.00682
	1.38	PULL	11.081	665	886	1108	2216	2770	4432	.00641
5.00	ALL	PUSH	19.635	1178	1571	1964	3927	4908	7854	.01136
	1.00	PULL	18.850	1131	1508	1885	3770	4712	7540	.01090
	1.38	PULL	18.150	1089	1452	1815	3630	4537	7260	.01050
6.00	ALL	PUSH	28.274	1696	2262	2827	5655	7068	11310	.01636
	1.38	PULL	26.789	1607	2144	2679	5358	6697	10716	.01550
	1.75	PULL	25.869	1552	2070	2587	5174	6467	10348	.01497
8.00	ALL	PUSH	50.265	3016	4021	5026	10053	12566	20106	.02908
	1.38	PULL	48.780	2927	3902	4878	9756	12195	19512	.02832
	1.75	PULL	47.860	2872	3829	4786	9572	11965	19144	.02770
10.00	ALL	PUSH	78.540	4712	6283	7854	15708	19635	31416	.04545
	1.75	PULL	76.130	4568	6090	7613	15226	19032	30452	.04406
	2.00	PULL	75.400	4524	6032	7540	15080	18850	30160	.04363
12.00	ALL	PUSH	113.098	6786	9048	11310	22620	28275	45239	.06545
	2.00	PULL	109.956	6597	8796	10996	21992	27489	43982	.06363
	2.50	PULL	108.189	6491	8655	10819	21638	27047	43276	.06261

\* Theoretical force. Actual force will be reduced by friction.

## TORQUE CHARTS

### CYLINDER TIE RODS

CYLINDER BORE	TIE ROD THREAD SIZE	TORQUE IN FT.-LBS.
1.50	1/4 - 28	7
2.00	5/16 - 24	12
2.50	5/16 - 24	14
3.25	3/8 - 24	30
4.00	3/8 - 24	35
5.00	1/2 - 20	45
6.00	1/2 - 20	50
8.00	5/8 - 18	125
10.00	3/4 - 16	125
12.00	3/4 - 16	125

### RETAINER SCREWS

CYLINDER BORE	SIZE	TORQUE IN FT.-LBS.
2.00 - 2.50	#10-32 S.H.C.S.	5
3.25 - 12.00	1/4-28 S.H.C.S.	12

Tighten cylinders using an "X" tightening pattern on tie rods.

ROD CLEVIS DIMENSIONS									
PART NUMBER	MAX LOAD (TENSION) RATED IN LBS	CB	CD (DIA.)	CE	CH	CW	ER (RADIUS)	KK	L
2834L59-A	2950	0.750	0.500	1.500	1.000	0.500	0.500	7/16-20	0.750
2835L59-A	11200	1.250	0.750	2.375	1.250	0.625	0.750	3/4-16	1.250
2836L59-A	19500	1.500	1.000	3.125	1.500	0.750	1.000	1-14	1.500
2837L59-A	26800	2.000	1.375	4.125	2.000	1.000	1.375	1-1/4-12	2.125
2838L59-A	39500	2.500	1.750	4.500	2.375	1.250	1.750	1-1/2-12	2.250
2839L59-A	56000	2.500	2.000	5.500	3.000	1.250	2.000	1-7/8-12	2.500

**ROD CLEVIS**

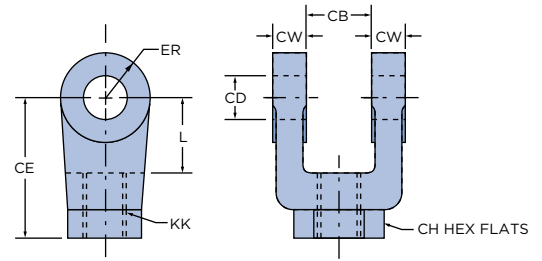

**MATERIAL: CAST STEEL  
FINISH: BLACK OXIDE**

**(Clevis Pins sold separately from Rod Clevises)**  
Note: When using a Rod Clevis in combination with an Eye Bracket, the operating angle is limited to +/-75° from the bracket center line.

EYE BRACKET DIMENSIONS										
PART NUMBER	MAX LOAD (TENSION) RATED IN LBS	BA	CB	CD (DIA.)	DD	E	F	FL	L	M
2716L47-A	3375	1.625	0.750	0.500	0.406	2.500	0.375	1.125	0.750	0.500
2719L32-A	8400	2.563	1.250	0.750	0.531	3.500	0.625	1.875	1.250	0.750
2720L33-A	13500	3.250	1.500	1.000	0.656	4.500	0.750	2.250	1.500	1.000
2721L34-A	25000	3.813	2.000	1.375	0.656	5.000	0.875	3.000	2.125	1.375
2722L35-A	45000	4.938	2.500	1.750	0.906	6.500	0.875	3.125	2.250	1.750
2723L36-A	45000	5.750	2.500	2.000	1.063	7.500	1.000	3.500	2.500	2.000

**EYE BRACKET**

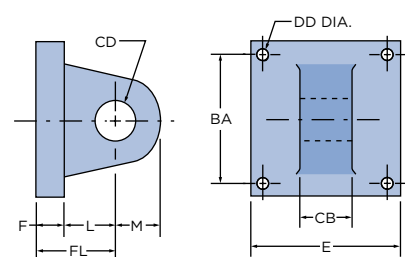

**MATERIAL: CAST STEEL  
FINISH: BLACK OXIDE**

**(Clevis Pins sold separately from Eye Brackets)**

CLEVIS PIN (WITH COTTER PINS)			
PART NUMBER	CD (DIA.)	LH	LP
3222L47-1-A	0.500	2.250	1.938
3222L47-2-A	0.750	3.000	2.719
3222L47-3-A	1.000	3.500	3.219
3222L47-4-A	1.375	5.000	4.250
3222L47-5-A	1.750	6.000	5.500
3222L47-6-A	2.000	6.000	5.500

**CLEVIS PIN (INCLUDES COTTER PIN)**

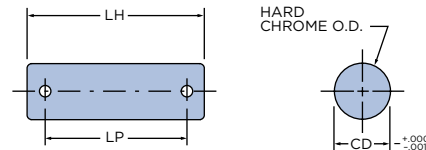

**MATERIAL: 1045 CRS  
FINISH: CHROME PLATED O.D.**

ROD EYE DIMENSIONS							
PART NUMBER	MAX LOAD (TENSION) RATED IN LBS	A	CA	CB	CD (DIA.)	ER (RADIUS)	KK
1810L59-A	2950	0.750	1.500	0.750	0.500	0.625	7/16-20
1812L59-A	8400	1.125	2.063	1.250	0.750	0.875	3/4-16
1813L59-A	13500	1.625	2.813	1.500	1.000	1.180	1-14
1814L59-A	24500	2.000	3.438	2.000	1.375	1.563	1-1/4-12
1815L59-A	39000	2.250	4.000	2.500	1.750	2.000	1-1/2-12
1817L59-A	45000	3.000	5.000	2.500	2.000	2.500	1-7/8-12

**ROD EYE**

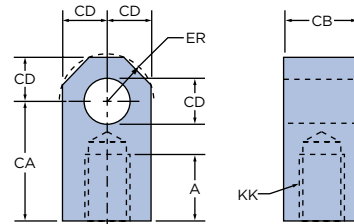

**MATERIAL: 1018 CRS  
FINISH: BLACK OXIDE**

**(Clevis Pins sold separately from Rod Eyes)**  
Note: When using a Rod Eye in combination with a Clevis Bracket, the operating angle is limited to +/-90° from the bracket center line.

CLEVIS BRACKET DIMENSIONS											
PART NUMBER	MAX LOAD (TENSION) RATED IN LBS	BA	CB	CD (DIA.)	CW	DD	E	F	FL	L	M
2683L47-A	4500	1.625	0.750	0.500	0.500	3/8-24	2.500	0.375	1.125	0.750	0.500
2684L47-A	8400	2.563	1.250	0.750	0.625	1/2-20	3.500	0.625	1.875	1.250	0.750
2685L47-A	13500	3.250	1.500	1.000	0.750	5/8-18	4.500	0.750	2.250	1.500	1.000
2686L47-A	34000	3.813	2.000	1.375	1.000	5/8-18	5.000	0.875	3.000	2.125	1.375
2687L47-A	54000	4.938	2.500	1.750	1.250	7/8-14	6.500	0.875	3.125	2.250	1.750
2688L47-A	89000	5.750	2.500	2.000	1.250	1-14	7.500	1.000	3.500	2.500	2.000

**CLEVIS BRACKET**

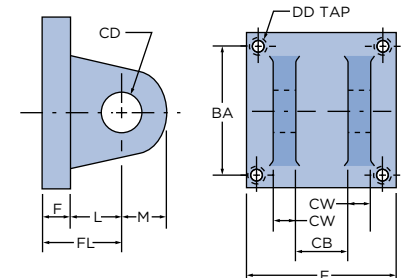

**MATERIAL: CAST STEEL  
FINISH: BLACK OXIDE**

**(Clevis Pins sold separately from Clevis Brackets)**



## REED SWITCH WITH BRACKET

Miniature Reed Switch, 24" (24 AWG Wire, PVC Jacket)  
Plain Cable Lead, Circuit Protection (2 wire Switch)

BORE SIZE	PART NUMBER
1.50" - 2.50"	19456E00-1
3.25" - 12.00"	19456E00-2

**Contacts** SPST Form A (Normally Open)  
**Contact Rating** 10 Watts Max.  
**Input Voltage** 120 Volts Max. (AC or DC)  
**Maximum Load Current** 150 mA Max.  
**Actuating Time Average** 1.0 millisecond  
**LED Indicator** High Luminescence Housing  
**Temperature Range** -4°F to 158°F (-20°C to 70°C)  
**Protection Rating** IP67

### Circuit Protection

**Varistor** 138 Volts  
**Choke** 680  $\mu$ H



**NOTE:** The circuit protection consists of a Varistor and Choke arrangement. The Varistor will take transient & voltage spikes out of the line and is mounted in parallel with the switch. The Choke will disperse inrush currents (normally caused by long cable runs) and is mounted in series with the switch.

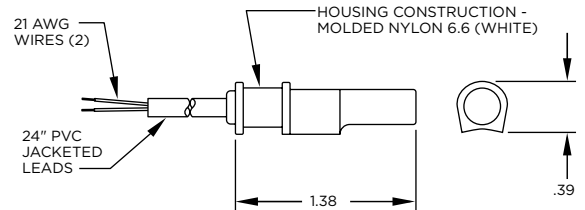

### WIRING DIAGRAM

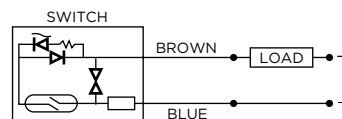

Miniature Reed Switch, Cable Type (2 Wire Switch)  
**Input Voltage** 120 Volts Max. AC/DC  
**Maximum Load Current** 150 mA Max.

### SWITCH BRACKET

(For 1.50" Through 2.50" Bore Cylinders)

**Bracket Construction:** Molded Nylon 6 (Black) and Stainless Steel Hardware

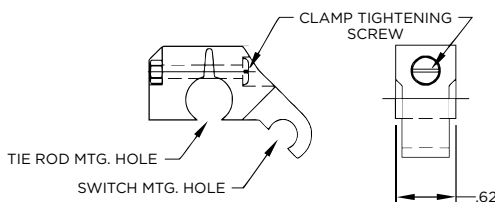

### SWITCH BRACKET

(For 3.25" Through 12.00" Bore Cylinders)

**Bracket Construction:** Molded Nylon 6 (Black) and Stainless Steel Hardware

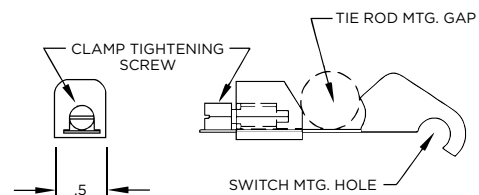

### HOW TO ASSEMBLE SWITCH AND BRACKETS

**Recommended Torque:**  
6-10 Inch-Lbs.  
(Do Not Exceed 14 Inch-Lbs.)

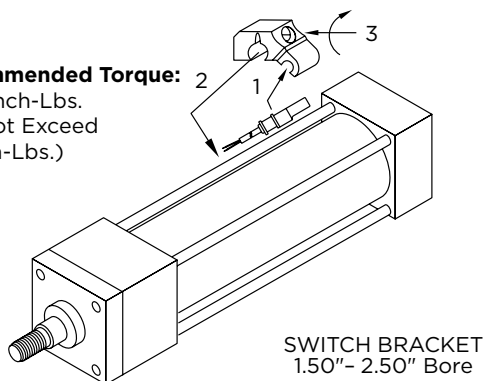

**Recommended Torque:**  
8-12 Inch-Lbs.  
(Do Not Exceed 14 Inch-Lbs.)

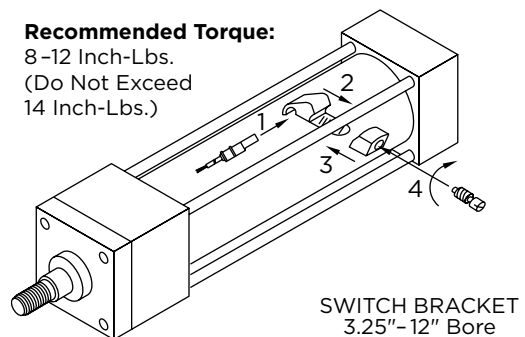

**Specify Magnetic Piston option for ALL switch models when ordering cylinders.**

## EXTENDED PISTON ROD THREAD

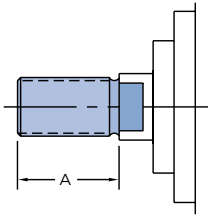

“A” refers to the length of piston rod thread.

Shorter than standard lengths can be furnished at no charge. Longer than standard lengths can be furnished at a nominal price adder.

## EXTENDED PISTON ROD

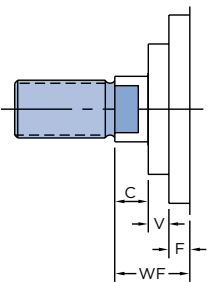

“WF” is commonly referred to as Piston Rod Extension.

Piston rods can be extended to any length up to 120” total piston rod length, including stroke portion. Cylinders with long “WF” lengths can be mounted away from obstacles or outside hazardous environments.

## STUDED PISTON ROD

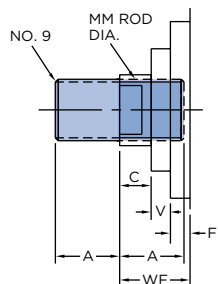

Type 9 combines the Type 5 female threaded rod end design and a case-hardened stud, with permanent Loctite®. When assembled, the Type 9 has the same dimensions as a Type 4 rod end.

This option is useful in applications that typically break standard Type 4 rod ends due to high load impacting.

## SPECIAL ROD THREAD

NPAK can machine virtually any diameter and type of rod thread on the piston rod end. Standard NFPA rod threads are UNF (fine), class 2 threads. Common alternative choices are UNC (course) threads. Some uncommon thread choices are threads larger than the rod diameter. This is only possible by providing a Type 5 (female) rod end and making a stud with the larger rod thread.

**NOTE:** Unless otherwise specified, the rod thread will be standard catalog “A” dimension lengths.

## METRIC ROD THREAD

ISO 6431 is a very popular European tie rod cylinder design. Equipment that is imported from outside the United States typically will contain metric tie-rod cylinders. In general, ISO 6431 tie rod cylinders are not as robust as NFPA cylinder designs and some customers prefer to replace the metric cylinders with NFPA designs that will provide longer life.

NPAK can provide cylinders with metric piston rod end threads to assist customers in mating replacement cylinders to existing equipment.

## OVERSIZE ROD



OVERSIZED PISTON ROD

STANDARD PISTON ROD

Applications requiring long strokes may require oversize piston rod diameters to prevent sagging or buckling. To determine the recommended rod diameter, refer to Chart 3 on page 93.

## METALLIC ROD SCRAPER

Aggressively scrapes the piston rod, removing foreign material such as spatter, sprays and powders (brass construction).

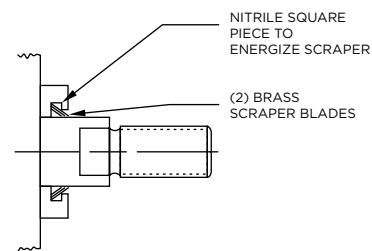

# OPTIONS AND MODIFICATIONS

## ROD COUPLER END

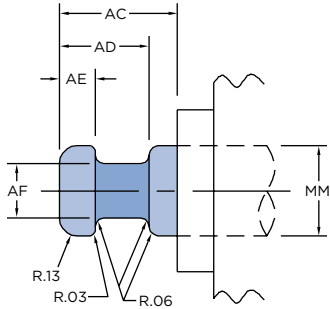

The Type 7 rod end was made popular in 3000 PSI hydraulic applications due to its versatility and high strength. Typically, a commercially available split flange end coupler and weld plate is used to connect the cylinder directly to the work that is being performed.

ROD DIAMETER (MM)	AC	AD	AE	AF
0.63	1.125	0.625	0.250	0.375
1.00	1.625	0.938	0.375	0.688
1.38	1.750	1.062	0.375	0.875
1.75	2.000	1.313	0.500	1.125
2.00	2.625	1.688	0.625	1.375
2.50	3.250	1.938	0.750	1.750

## MAGNETIC PISTON

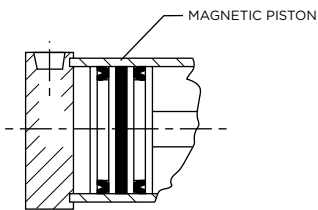

Magnetic Pistons are used in conjunction with NOPAK Reed Switches. (See page 89 for switches).

## OPTIONAL PORT LOCATION

Optional port locations can be ordered simply by calling out the location numbers.

**NOTE:** When optional port locations are ordered, specify both port locations, even if one port is in the standard location.

- STANDARD PORT POSITIONS @ 1
- STANDARD CUSHION POSITIONS @ 2
- SPECIFY NON-STANDARD LOCATIONS WHEN ORDERING

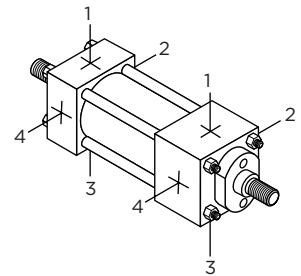

## FLUOROCARBON SEALS

Type B Option contains two (2) Fluorocarbon U-Cup piston seals, Bushing O-Ring, rod seal and rod wiper.

Fluorocarbon seal material has an overall shorter seal life due to the higher wear rate inherent with the material. In general, Fluorocarbon seals should only be specified when temperatures exceed 200°F for prolonged periods of time or when there is a fluid compatibility issue with standard seals.

### BENEFITS OF FLUOROCARBON SEALS:

- Higher temperature performance: 0°F to 400°F (-20°C to 200°C)
- Higher chemical resistance: Resists most wash down solutions

Many other seal materials are available. Contact NOPAK for proper seal material selection in tough applications or environments.

## ELECTROLESS NICKEL

Electroless Nickel (EMS-201) plating was invented in 1946 and has gained worldwide commercial usage since 1964. Common usages include aircraft landing gear, automotive brake cylinder and components, fuel injector parts, gas turbine parts, spray nozzles for chemical applications and many electronic devices including hard drives.

The properties of Electroless Nickel contribute to the multitude of uses. The coating provides an attractive finish, while exhibiting high abrasion and corrosion resistance. Its ability to uniformly coat blind holes, threads, internal surfaces and sharp edges contributes to its effectiveness. It has a very high bonding strength to the base metal (100,000-200,000 PSI), so much so that gas turbines use electroless nickel plating as a base to braze broken blades to.

### EMS-201 CYLINDER SPECIFICATIONS

#### EMS-201 PLATED PARTS:

Tube, Head, Cap, Bushing Retainer, Mounts (excluding FR/FB, which is hard chrome plated stainless steel).

#### OTHER COMPONENTS:

303/304 Stainless Steel: Tie Rods & Nuts, Retainer Screws, Piston Rod (hard chrome plated), Rod Bushing with PTFE Wear Band and Rod Wiper.

### EMS-201 PLATING SPECIFICATIONS:

<b>HIGH PHOSPHORUS</b>	Highest corrosion resistant Electroless Nickel plating available
<b>COMPOSITION:</b>	87- 90% Nickel, 10 -13% Phosphorus
<b>HARDNESS:</b>	Rc 46-48
<b>THICKNESS:</b>	.0005" - .0007"
<b>LUBRICITY:</b>	Excellent (Similar to chrome)
<b>COEFFICIENT OF FRICTION:</b>	Low
<b>FINISH:</b>	Bright and very smooth

## STAINLESS STEEL

Stainless Steel, when used in conjunction with Anodized Aluminum Heads, Caps and Tube, provides corrosion resistance in outdoor applications and wet environments.

Customize your cylinder by choosing from Stainless Steel Fasteners, Piston Rod or Tie Rods & Nuts.

Stainless Steel Piston Rod (Hard-Chrome Plated), Stainless Steel Fasteners, Stainless Steel Tie Rods & Nuts	Stainless Steel Cushion Needle (External Adjustment Components)
Stainless Steel Tie Rods and Nuts	Stainless Steel Fasteners (Bushing Retainer Screws)
Stainless Steel Piston Rod (Hard-Chrome Plated)	

## STOP TUBE

Stop Tubes are designed to reduce the piston rod bushing stress to within the designed range of the bearing material. This will ensure proper cylinder performance, in any given application. Stop Tubes lower the cylinder bearing stress by adding length to the piston, which increases the overall length of the cylinder.

**NOTE:** NOPAK uses a double piston design for 2" and longer stop tubes.

## STOP TUBE SELECTION

To determine the proper amount of stop tube for your application, you must first find the value of "D," which represents the "stroke, adjusted for mounting condition." Each mounting condition creates different levels of bushing stress, which have direct impact on the amount of stop tube required (see Chart 1).

Once the value of "D" is known, refer to Chart 2 for the recommended amount of stop tube.

**To order a Stop Tube, add the stop tube prefix "ST=" and the length, to the end of your cylinder model number.**

**The effective stroke (ES) must be included when ordering.**

## CHART 1

**Find the value of "D" for your application**

**NOTE:** Measure "D" when cylinder is fully extended.

"D" = Stroke, adjusted for mounting condition

"S" = Actual cylinder stroke

"T" = Axial thrust (refer to Chart 3)

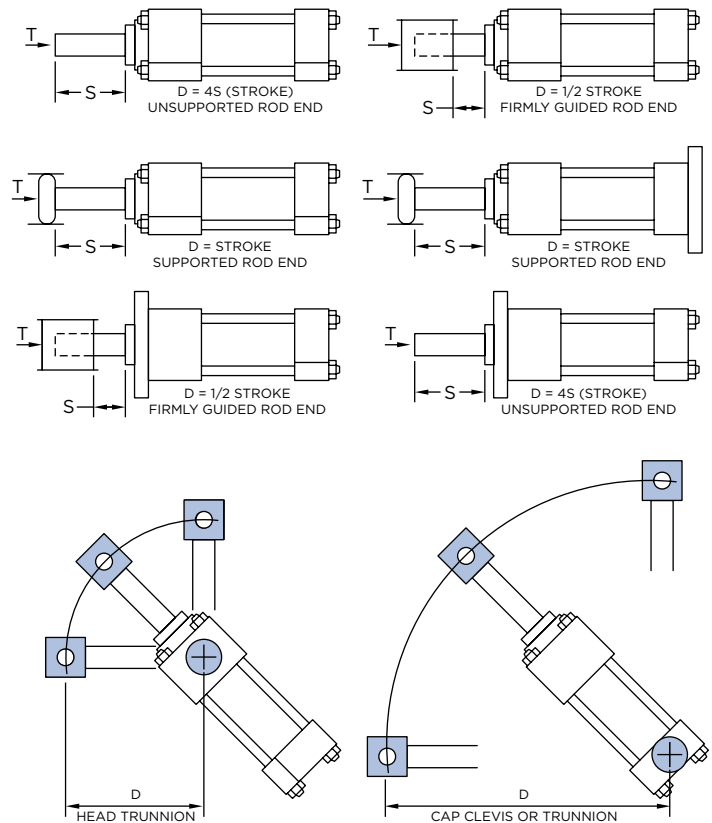

## CHART 2

Using the value of "D", find the recommended amount of stop tube

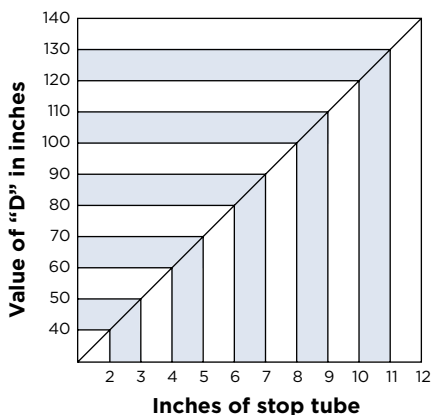

## CHART 3

**Rod size selection**

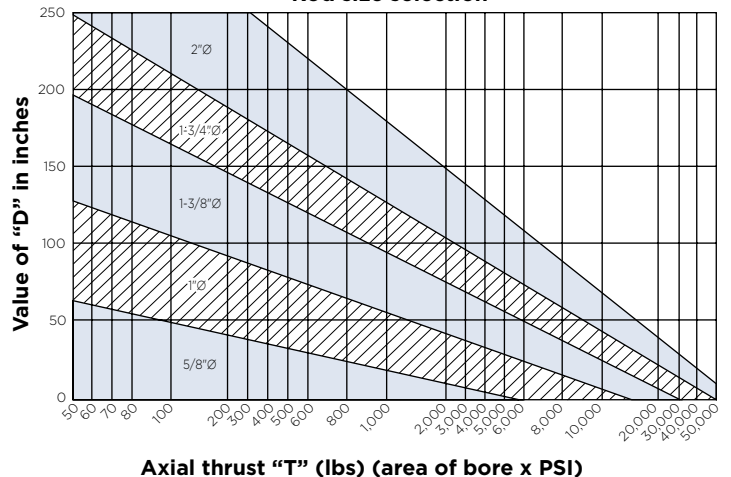



# Class 6

## Intermediate Pressure Square-Head Cylinders

---

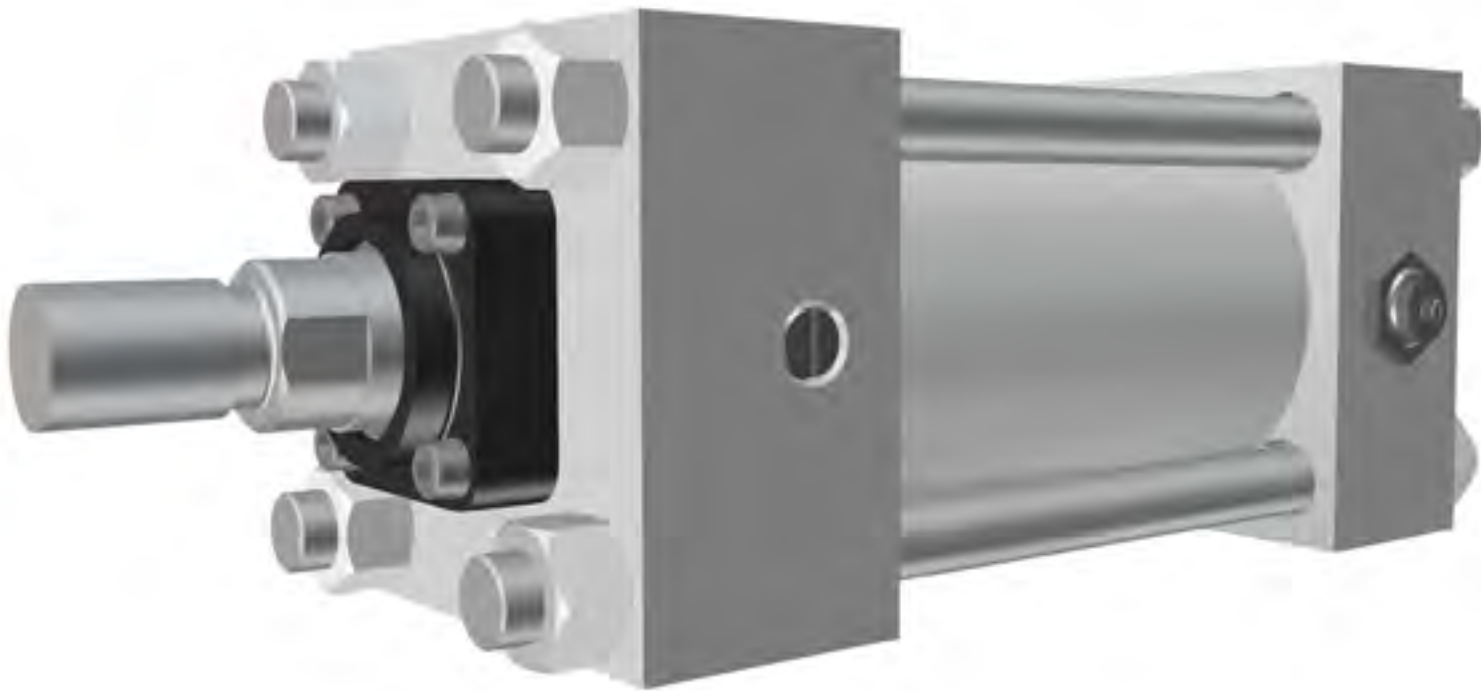

## TABLE OF CONTENTS

Pressure Ratings (PSI) .....	96
Mounting Styles Index .....	97
Standard Features .....	98
Ordering Information .....	99
Flange Mount Cylinders	
1-1/2" Through 6" Bore .....	100
8" Through 20" Bore .....	102
Side and Lug Mount Cylinders	
1-1/2" Through 6" Bore .....	104
8" Through 20" Bore .....	106
End Lug and Clevis Mount Cylinders	
1-1/2" Through 8" Diameter .....	108
10" Through 20" Diameter .....	110
Fixed Eye Mount Cylinders	
1-1/2" Through 8" Diameter .....	112
Detachable Eye Mount Cylinders	
1-1/2" Through 10" Diameter .....	114
Spherical Eye Mount Cylinders	
1-1/2" Through 6" Diameter .....	116
Trunnion Mount Cylinders	
1-1/2" Through 6" Diameter .....	118
8" Through 20" Diameter .....	120
Tie-Rod Mount Cylinders	
1-1/2" Through 6" Diameter .....	122
8" Through 20" Diameter .....	124
Spherical Eye Pin Mount Cylinders	
1-1/2" Through 6" Diameter .....	126
Basic Model No Mount Cylinders	
1-1/2" Through 6" Diameter .....	128
8" Through 20" Diameter .....	130
Piston Rod Ends .....	132
Cylinder Accessories .....	133
Reed Proximity Switch .....	134
Proximity Position Indicator Switch .....	135
NOPAK Linear Displacement Transducer System .....	136
NLDT System Switch Number .....	137
How To Order .....	137
Engineering Information .....	138
Engineering Data .....	140
Replacement Parts .....	142
Exploded View .....	142
Repair Kits - Class P6 and H6 .....	143
Packing Glands - Class P6 and H6 .....	143

## PRESSURE RATINGS (PSI)

NOPAK intermediate pressure square-head cylinders are designed as Class P6 for pneumatic (air) services to 250 PSI Class H6 for hydraulic service to 1500 PSI.

CYL. BORE	P6 (AIR)		H6 (HYD.)	
	RECOMMENDED CONTINUOUS DUTY OPERATING PRESSURE	MAXIMUM NON-CONTINUOUS PRESSURE RATING	RECOMMENDED CONTINUOUS DUTY OPERATING PRESSURE	MAXIMUM NON-CONTINUOUS PRESSURE RATING
1-1/2	250	750	1500	2500
2	250	750	1500	2500
2-1/2	250	500	1100	1600
3-1/4	250	650	1050	1550
4	250	400	750	1000
5	250	400	900	1200
6	200	250	500	700
8	200	250	500	800
10	200	250	400 Steel Tube	800 Steel Tube
			400 Brass Tube	450 Brass Tube
12	200	250	400	800
14	200	250	400	800
16	200	250	200	500
18	200	250	200	500
20	200	250	200	500

**Note 1** — In addition to the pressure ratings, proper choice and application of a cylinder are dependent on mounting type, stroke, method of load application, fluid, temperature, environment, and other such conditions. For specific recommendations, consult your nearest NOPAK field representative or factory application engineer.

**Note 2** — While P6 cylinders are designed primarily for air service as noted, they are also suitable for limited range low-pressure hydraulic service, consult factory. Unless otherwise specified any order received for a hydraulic cylinder will be entered as Class H6.

**Note 3** — Maximum non-continuous ratings should be used only when all operating conditions are accurately known and *only* on applications intended for intermittent duty. For specific recommendations consult your nearest NOPAK field representative or factory application engineer.

**Note 4** — For pressures above these ratings, refer to NOPAK Class 3 High Pressure Hydraulic Cylinders in the Class 3 Section.

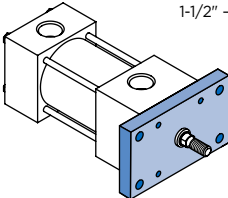
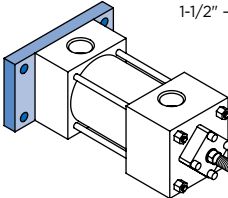
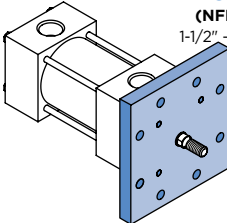
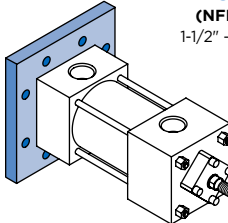
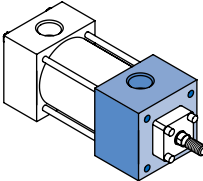
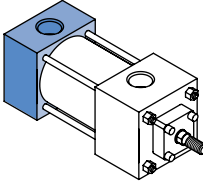
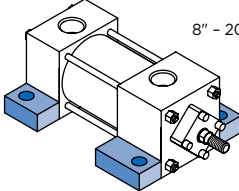
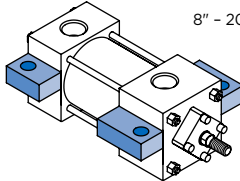
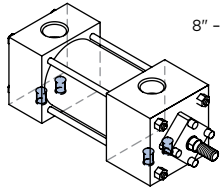
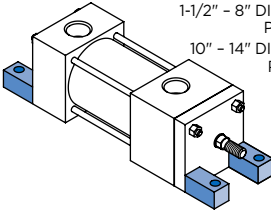
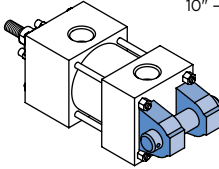
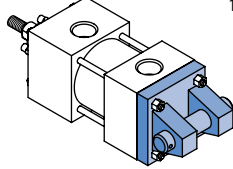
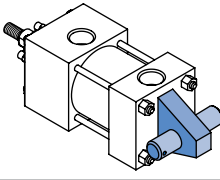
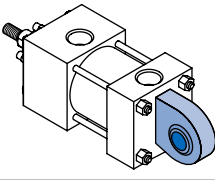
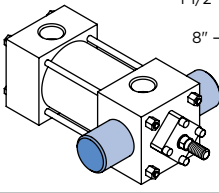
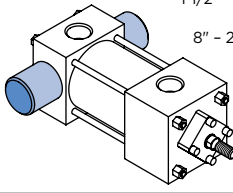
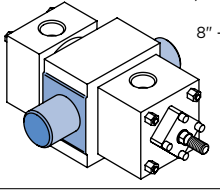
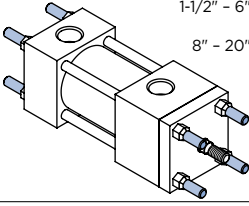
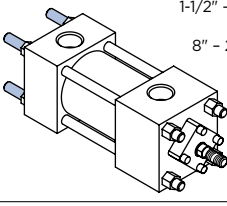
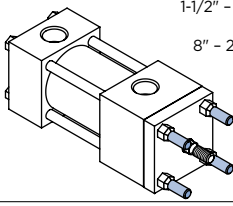
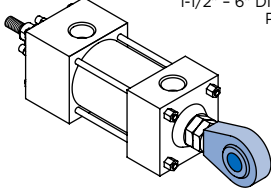
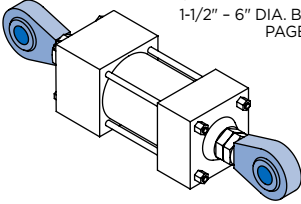
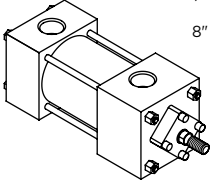
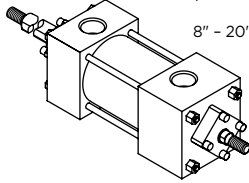

# MOUNTING STYLES INDEX

 <p><b>MODEL D</b> (NFPA STD. MF1) 1-1/2" - 6" DIA. BORE PAGE 100</p>	 <p><b>MODEL C</b> (NFPA STD. MF2) 1-1/2" - 6" DIA. BORE PAGE 100</p>	 <p><b>MODEL DD</b> (NFPA STD. MF5) 1-1/2" - 6" DIA. BORE PAGE 100</p>	 <p><b>MODEL CC</b> (NFPA STD. MF6) 1-1/2" - 6" DIA. BORE PAGE 100</p>
 <p><b>MODEL DG</b> (NFPA STD. ME3) 8" - 20" DIA. BORE PAGE 102</p>	 <p><b>MODEL CJ</b> (NFPA STD. ME4) 8" - 20" DIA. BORE PAGE 102</p>	 <p><b>MODEL A</b> (NFPA STD. MS2) 1-1/2" - 6" DIA. BORE PAGE 104 8" - 20" DIA. BORE PAGE 106</p>	 <p><b>MODEL B</b> (NFPA STD. MS3) 1-1/2" - 6" DIA. BORE PAGE 104 8" - 20" DIA. BORE PAGE 106</p>
 <p><b>MODEL S</b> (NFPA STD. MS4) 1-1/2" - 8" DIA. BORE PAGE 104 8" - 20" DIA. BORE PAGE 106</p>	 <p><b>MODEL AL</b> (NFPA STD. MS7) 1-1/2" - 8" DIA. BORE PAGE 108 10" - 14" DIA. BORE PAGE 110</p>	 <p><b>MODEL E</b> (NFPA STD. MP1) 1-1/2" - 8" DIA. BORE PAGE 108 10" - 20" DIA. BORE PAGE 110</p>	 <p><b>MODEL HE</b> (NFPA STD. MP2) 1-1/2" - 8" DIA. BORE PAGE 108 10" DIA. BORE PAGE 110</p>
 <p><b>MODEL E3</b> (NFPA STD. MP3) 1-1/2" - 8" DIA. BORE PAGE 112</p>	 <p><b>MODEL EU3</b> (NFPA STD. MPU3) 1-1/2" - 6" DIA. BORE PAGE 116</p>	 <p><b>MODEL FR</b> (NFPA STD. MT1) 1-1/2" - 6" DIA. BORE PAGE 118 8" - 20" DIA. BORE PAGE 120</p>	 <p><b>MODEL FB</b> (NFPA STD. MT2) 1-1/2" - 6" DIA. BORE PAGE 118 8" - 20" DIA. BORE PAGE 120</p>
 <p><b>MODEL F</b> (NFPA STD. MT4) 1-1/2" - 6" DIA. BORE PAGE 118 8" - 14" DIA. BORE PAGE 120</p>	 <p><b>MODEL T</b> (NFPA STD. MX1) 1-1/2" - 6" DIA. BORE PAGE 122 8" - 20" DIA. BORE PAGE 124</p>	 <p><b>MODEL TB</b> (NFPA STD. MX2) 1-1/2" - 6" DIA. BORE PAGE 122 8" - 20" DIA. BORE PAGE 124</p>	 <p><b>MODEL TR</b> (NFPA STD. MX3) 1-1/2" - 6" DIA. BORE PAGE 122 8" - 20" DIA. BORE PAGE 124</p>
 <p><b>MODEL UE</b> (NFPA STD. NONE) 1-1/2" - 6" DIA. BORE PAGE 126</p>	 <p><b>MODEL UUE</b> (NFPA STD. NONE) 1-1/2" - 6" DIA. BORE PAGE 126</p>	 <p><b>MODEL H</b> (NFPA STD. NONE) 1-1/2" - 6" DIA. BORE PAGE 128 8" - 20" DIA. BORE PAGE 130</p>	 <p><b>MODEL XH</b> (NFPA STD. NONE) 1-1/2" - 6" DIA. BORE PAGE 128 8" - 20" DIA. BORE PAGE 130</p>

**NOTE:** NFPA-MS1 (NOPAK Model AP), ME5 (NOPAK MODEL G) and ME6 (NOPAK MODEL J) not shown, but available. Consult Factory.

**INTERMEDIATE PRESSURE SQUARE-HEAD  
CLASS P6-AIR & H6 HYDRAULIC CYLINDERS CUTAWAY VIEW**

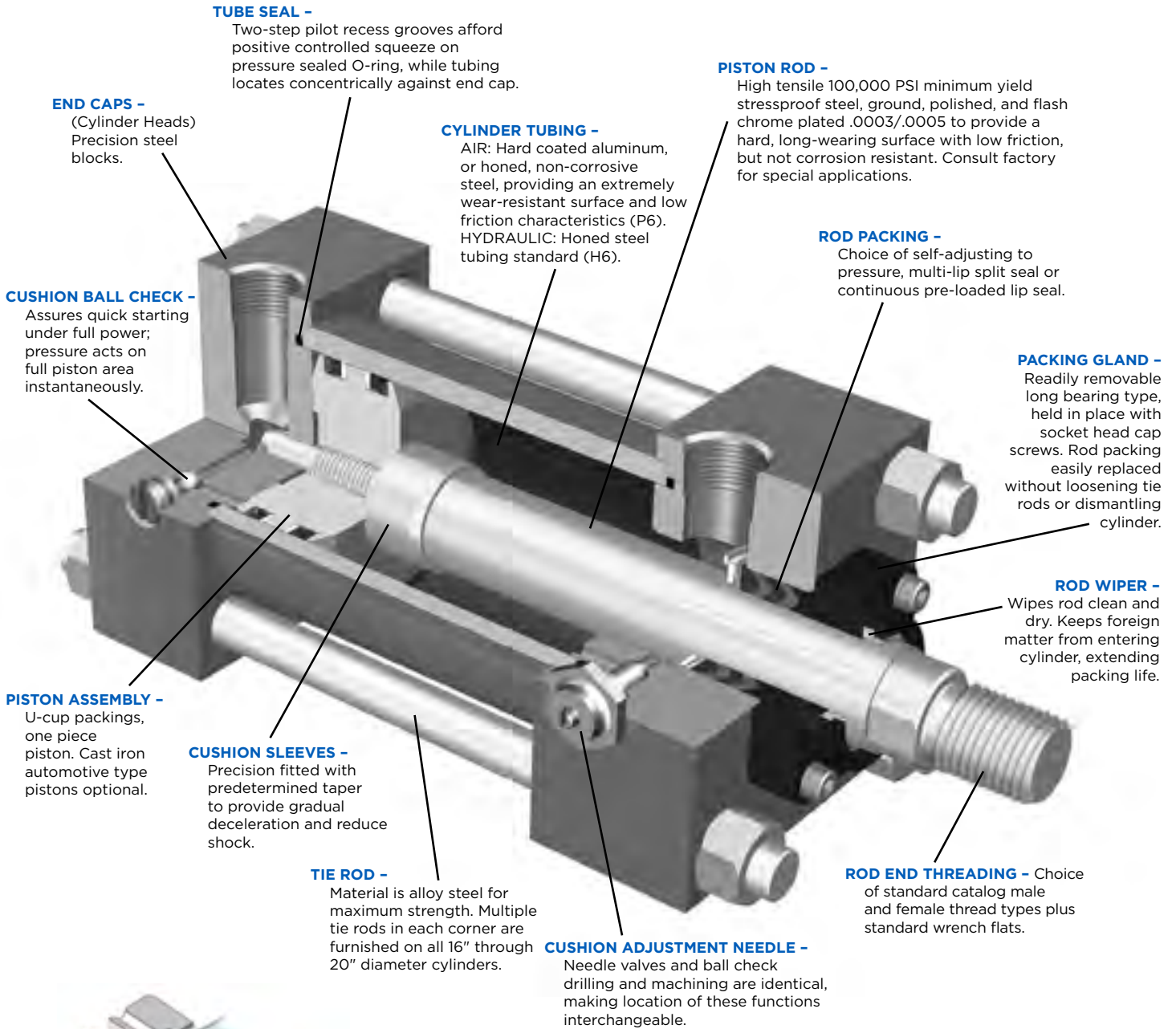

**ALTERNATE  
FLUSH  
CUSHION  
DESIGN**

## HOW TO ORDER

### YOU CAN HELP ENSURE PROMPT PROCESSING OF YOUR ORDER BY INCLUDING ALL OF THE FOLLOWING REQUESTED INFORMATION:

1. Quantity required.
2. Operating medium: Series P6 or H6.  
P for pneumatic and H for hydraulic.
3. Bore size.
4. Stroke length in inches.
5. Type of mounting (NOPAK Model or NFPA STD. style).
6. Type of cushioning:  
NN = non-cushioned  
NA = cushioned blind end  
AN = cushioned rod end  
AA = cushioned both ends
7. Piston rod diameter and type of rod threading - specify Type 1, 3, 4, 5, 6 or 7. See page 132.

### ALSO SPECIFY:

1. Position of cylinder ports and cushion adjustment screws, if other than standard. Standard positions are:  
National pipe thread inlets - position 1  
Ball check - position 2  
Cushion adjustment - position 4
2. Extreme high or low operating or ambient temperatures.
3. Type of hydraulic fluid if other than standard petroleum base oil.
4. Any unusual operating conditions.

### ORDERING CODE EXAMPLE

**CLP6 - 8 x 18 - A - ΔΔ - 1-3/8 - 4**

**Any special requirements should be described IN WORDS below model number.**

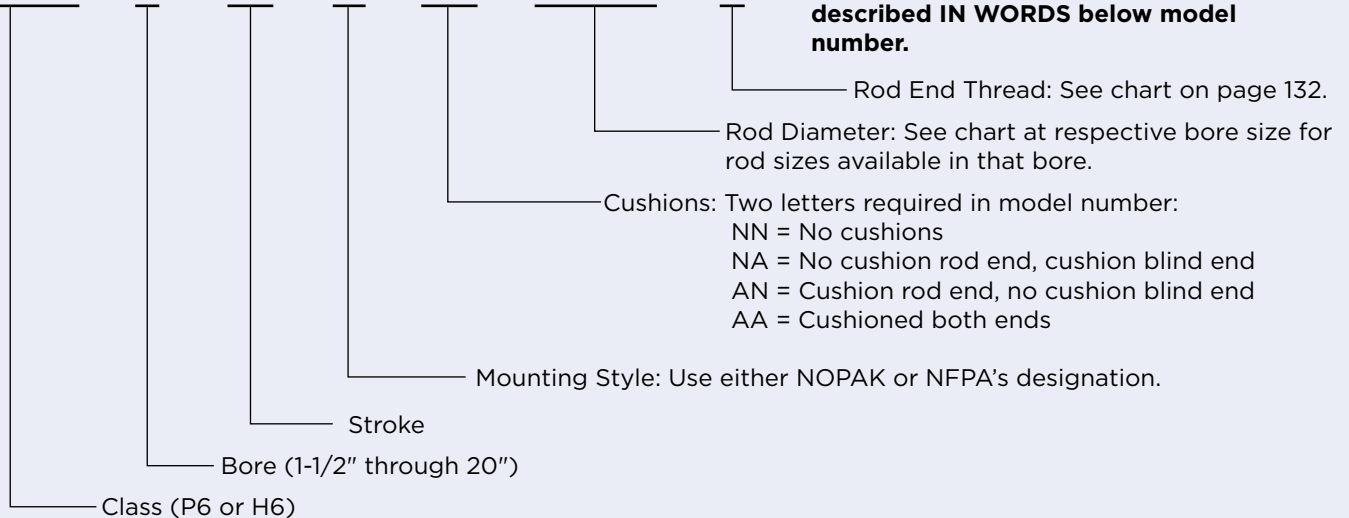

**MODEL C (NFPA STD. MF2)** ▲

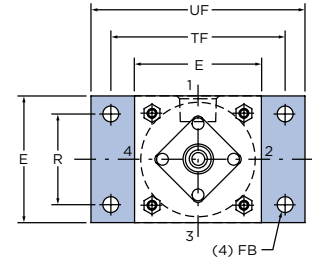
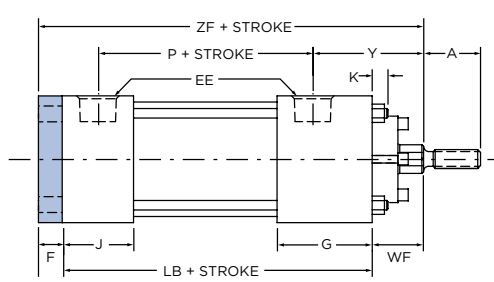
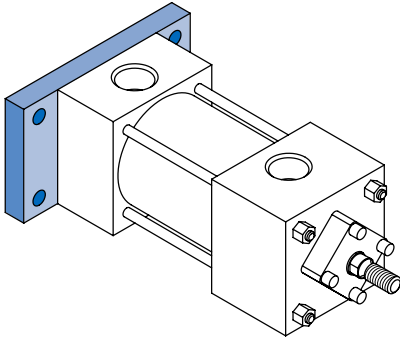

**MODEL CC (NFPA STD. MF6)** ▲

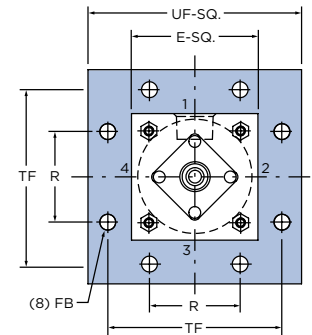
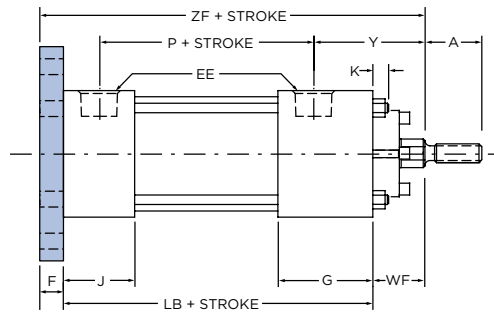
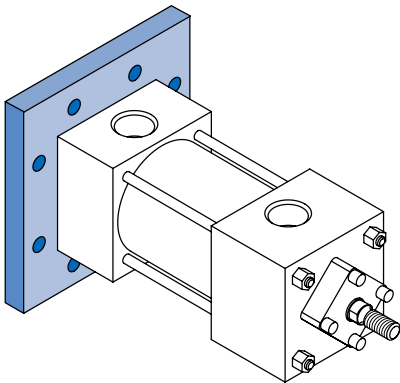

**MODEL D (NFPA STD. MF1)**

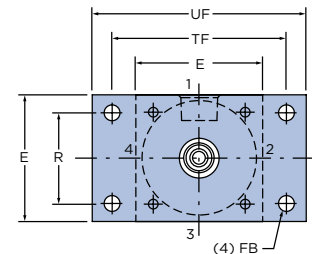
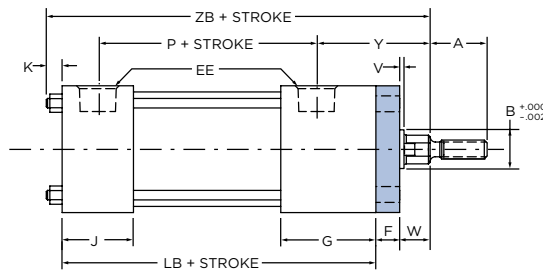
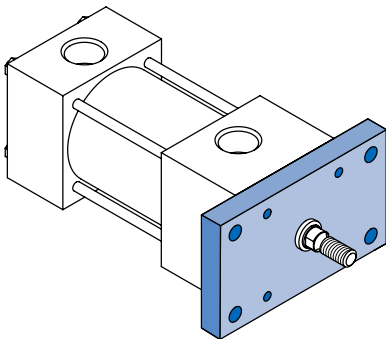

**MODEL DD (NFPA STD. MF5)**

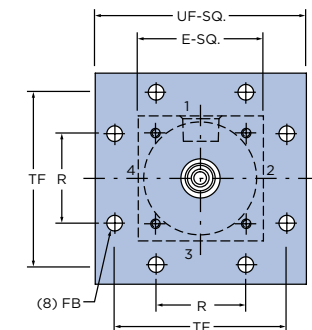
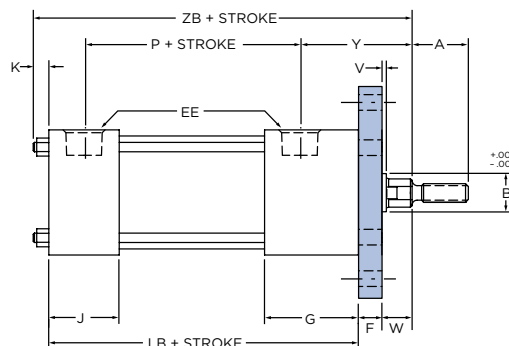
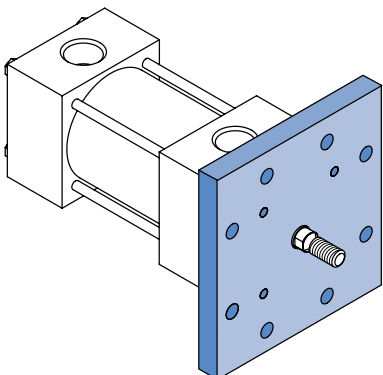

▲ = See Table A on page 127 for bore and rod combinations using head plates with threaded bronze glands.

# FLANGE MOUNT CYLINDERS

1-1/2" THROUGH 6" BORE

**Table 1** These dimensions are constant regardless of rod diameter or stroke.

Double rod end models are designated by letter "X" preceding the model identification. See page 128.

• = Dimensions refer to bolt diameter.

BORE DIA.	E	F	G	J	K	R	EE	FB•	TF	UF
1-1/2	2	3/8	1-1/2	1-1/8	1/4	1.43	3/8	1/4	2-3/4	3-3/8
2	2-1/2	3/8	1-1/2	1-1/8	7/16	1.84	3/8	5/16	3-3/8	4-1/8
2-1/2	3	3/8	1-1/2	1-1/8	5/16	2.19	3/8	5/16	3-7/8	4-5/8
3-1/4	3-3/4	5/8	1-3/4	1-1/4	7/16	2.76	1/2	3/8	4-11/16	5-1/2
4	4-1/2	5/8	1-3/4	1-1/4	7/16	3.32	1/2	3/8	5-7/16	6-1/4
5	5-1/2	5/8	1-3/4	1-1/4	1/2	4.10	1/2	1/2	6-5/8	7-5/8
6	6-1/2	3/4	2	1-1/2	9/16	4.88	3/4	1/2	7-5/8	8-5/8

**Table 2** The dimensions given on this table are affected by the piston rod diameter and the stroke.

• = For piston rod dimensions see page 132.

BORE DIA.	ROD MM•	A	B	P	V	W	Y	LB	WF	ZB	ZF
1-1/2	5/8	3/4	1-1/8	2-1/8	1/4	5/8	1-15/16	3-5/8	1	4-7/8	5
	1	1-1/8	1-1/2	2-1/8	1/2	1	2-5/16	3-5/8	1-3/8	5-1/4	5-3/8
2	5/8	3/4	1-1/8	2-1/8	1/4	5/8	1-15/16	3-5/8	1	5-1/16	5
	1	1-1/8	1-1/2	2-1/8	1/2	1	2-5/16	3-5/8	1-3/8	5-7/16	5-3/8
	1-3/8	1-5/8	2	2-1/8	5/8	1-1/4	2-9/16	3-5/8	1-5/8	5-11/16	5-5/8
2-1/2	5/8	3/4	1-1/8	2-1/4	1/4	5/8	1-15/16	3-3/4	1	5-1/16	5-1/8
	1	1-1/8	1-1/2	2-1/4	1/2	1	2-5/16	3-3/4	1-3/8	5-7/16	5-1/2
	1-3/8	1-5/8	2	2-1/4	5/8	1-1/4	2-9/16	3-3/4	1-5/8	5-11/16	5-3/4
	1-3/4	2	2-3/8	2-1/4	3/4	1-1/2	2-13/16	3-3/4	1-7/8	5-15/16	6
3-1/4	1	1-1/8	1-1/2	2-1/2	1/4	3/4	2-1/2	4-1/4	1-3/8	6-1/16	6-1/4
	1-3/8	1-5/8	2	2-1/2	3/8	1	2-3/4	4-1/4	1-5/8	6-5/16	6-1/2
	1-3/4	2	2-3/8	2-1/2	1/2	1-1/4	3	4-1/4	1-7/8	6-9/16	6-3/4
	2	2-1/4	2-5/8	2-1/2	1/2	1-3/8	3-1/8	4-1/4	2	6-11/16	6-7/8
4	1	1-1/8	1-1/2	2-1/2	1/4	3/4	2-1/2	4-1/4	1-3/8	6-1/16	6-1/4
	1-3/8	1-5/8	2	2-1/2	3/8	1	2-3/4	4-1/4	1-5/8	6-5/16	6-1/2
	1-3/4	2	2-3/8	2-1/2	1/2	1-1/4	3	4-1/4	1-7/8	6-9/16	6-3/4
	2	2-1/4	2-5/8	2-1/2	1/2	1-3/8	3-1/8	4-1/4	2	6-11/16	6-7/8
	2-1/2	3	3-1/8	2-1/2	5/8	1-5/8	3-3/8	4-1/4	2-1/4	6-15/16	7-1/8
5	1	1-1/8	1-1/2	2-3/4	1/4	3/4	2-1/2	4-1/2	1-3/8	6-3/8	6-1/2
	1-3/8	1-5/8	2	2-3/4	3/8	1	2-3/4	4-1/2	1-5/8	6-5/8	6-3/4
	1-3/4	2	2-3/8	2-3/4	1/2	1-1/4	3	4-1/2	1-7/8	6-7/8	7
	2	2-1/4	2-5/8	2-3/4	1/2	1-3/8	3-1/8	4-1/2	2	7	7-1/8
	2-1/2	3	3-1/8	2-3/4	5/8	1-5/8	3-3/8	4-1/2	2-1/4	7-1/4	7-3/8
	3	3-1/2	3-3/4	2-3/4	5/8	1-5/8	3-3/8	4-1/2	2-1/4	7-1/4	7-3/8
	3-1/2	3-1/2	4-1/4	2-3/4	5/8	1-5/8	3-3/8	4-1/2	2-1/4	7-1/4	7-3/8
6	1-3/8	1-5/8	2	3-1/8	1/4	7/8	2-13/16	5	1-5/8	7-3/16	7-3/8
	1-3/4	2	2-3/8	3-1/8	3/8	1-1/8	3-1/16	5	1-7/8	7-7/16	7-5/8
	2	2-1/4	2-5/8	3-1/8	3/8	1-1/4	3-3/16	5	2	7-9/16	7-3/4
	2-1/2	3	3-1/8	3-1/8	1/2	1-1/2	3-7/16	5	2-1/4	7-13/16	8
	3	3-1/2	3-3/4	3-1/8	1/2	1-1/2	3-3/16	5	2-1/4	7-13/16	8
	3-1/2	3-1/2	4-1/4	3-1/8	1/2	1-1/2	3-7/16	5	2-1/4	7-13/16	8
	4	4	4-3/4	3-1/8	1/2	1-1/2	3-7/16	5	2-1/4	7-13/16	8

**MODEL CJ (NFPA STD. ME4)**

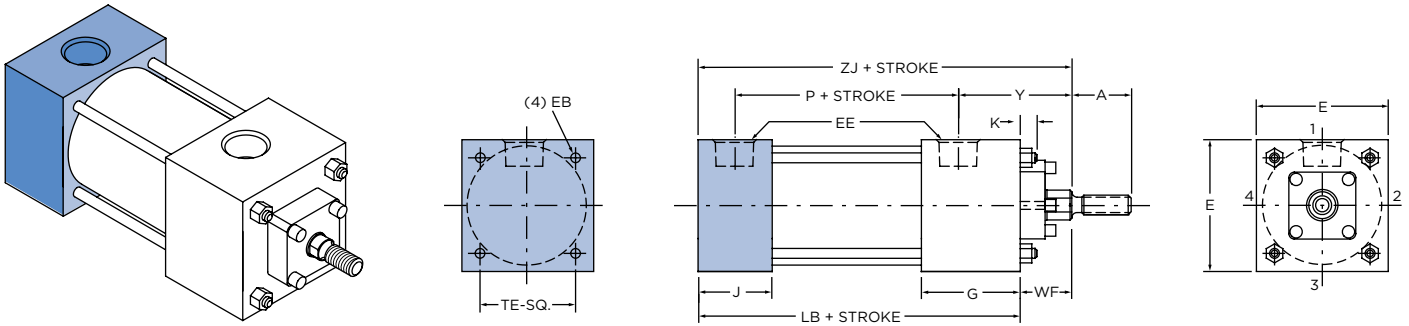

**MODEL DG (NFPA STD. ME3)**

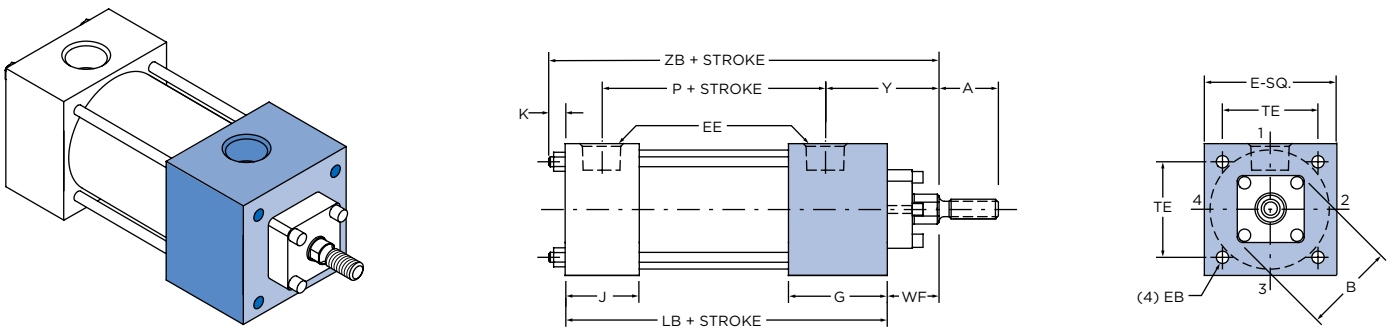

**Table 1** These dimensions are constant regardless of rod diameter or stroke.

Double rod end models are designated by letter "X" preceding the model identification. See page 128.

• = Dimensions refer to bolt diameter.

BORE DIA.	E	G	J	K	EB•	EE	TE
8	8-1/2	2	1-1/2	5/8	5/8	3/4	7.57
10	10-5/8	2-1/4	2	3/4	3/4	1	9.4
12	12-3/4	2-1/4	2	3/4	3/4	1	11.1
14	14-3/4	2-3/4	2-1/4	7/8	7/8	1-1/4	12.87
16	17-1/2	3	3	1	1-1/4	1-1/2	14-3/4
18	19-1/2	3-7/16	3-7/16	1-1/8	1-1/2	1-1/2	16-1/2
20	21-3/4	3-15/16	3-15/16	1-1/4	1-3/4	2	18-1/4

**Table 2** The dimensions given on this table are affected by the piston rod diameter and the stroke.

• = For piston rod dimensions see page 132.

BORE DIA.	ROD MM•	A	P	Y	LB	RM	WF	ZB	ZJ
8	1-3/8	1-5/8	3-1/4	2-13/16	5-1/8	3	1-5/8	7-3/8	6-3/4
	1-3/4	2	3-1/4	3-1/16	5-1/8	3-1/2	1-7/8	7-5/8	7
	2	2-1/4	3-1/4	3-3/16	5-1/8	4-1/8	2	7-3/4	7-1/8
	2-1/2	3	3-1/4	3-7/16	5-1/8	4-5/8	2-1/4	8	7-3/8
	3	3-1/2	3-1/4	3-7/16	5-1/8	5-1/2	2-1/4	8	7-3/8
	3-1/2	3-1/2	3-1/4	3-7/16	5-1/8	6-1/8	2-1/4	8	7-3/8
	4	4	3-1/4	3-7/16	5-1/8	6-7/8	2-1/4	8	7-3/8
	4-1/2	4-1/2	3-1/4	3-7/16	5-1/8	7-3/4	2-1/4	8	7-3/8
10	5	5	3-1/4	3-7/16	5-1/8	8-3/8	2-1/4	8	7-3/8
	5-1/2	5-1/2	3-1/4	3-7/16	5-1/8	9	2-1/4	8	7-3/8
	1-3/4	2	4	3-3/16	6-3/8	3-1/2	1-7/8	9	8-1/4
	2	2-1/4	4	3-5/16	6-3/8	4-1/8	2	9-1/8	8-3/8
	2-1/2	3	4	3-9/16	6-3/8	4-5/8	2-1/4	9-3/8	8-5/8
	3	3-1/2	4	3-9/16	6-3/8	5-1/2	2-1/4	9-3/8	8-5/8
	3-1/2	3-1/2	4	3-9/16	6-3/8	6-1/8	2-1/4	9-3/8	8-5/8
	4	4	4	3-9/16	6-3/8	6-7/8	2-1/4	9-3/8	8-5/8
12	4-1/2	4-1/2	4	3-9/16	6-3/8	7-3/4	2-1/4	9-3/8	8-5/8
	5	5	4	3-9/16	6-3/8	8-3/8	2-1/4	9-3/8	8-5/8
	5-1/2	5-1/2	4	3-9/16	6-3/8	9	2-1/4	9-3/8	8-5/8
	2	2-1/4	4-1/2	3-5/16	6-7/8	4-1/8	2	9-5/8	8-7/8
	2-1/2	3	4-1/2	3-9/16	6-7/8	4-5/8	2-1/4	9-7/8	9-1/8
	3	3-1/2	4-1/2	3-9/16	6-7/8	5-1/2	2-1/4	9-7/8	9-1/8
	3-1/2	3-1/2	4-1/2	3-9/16	6-7/8	6-1/8	2-1/4	9-7/8	9-1/8
	4	4	4-1/2	3-9/16	6-7/8	6-7/8	2-1/4	9-7/8	9-1/8
14	4-1/2	4-1/2	4-1/2	3-9/16	6-7/8	7-3/4	2-1/4	9-7/8	9-1/8
	5	5	4-1/2	3-9/16	6-7/8	8-3/8	2-1/4	9-7/8	9-1/8
	5-1/2	5-1/2	4-1/2	3-9/16	6-7/8	9	2-1/4	9-7/8	9-1/8
	2-1/2	3	5-1/2	3-13/16	8-1/8	4-5/8	2-1/4	11-1/4	10-3/8
	3	3-1/2	5-1/2	3-13/16	8-1/8	5-1/2	2-1/4	11-1/4	10-3/8
	3-1/2	3-1/2	5-1/2	3-13/16	8-1/8	6-1/8	2-1/4	11-1/4	10-3/8
	4	4	5-1/2	3-13/16	8-1/8	6-7/8	2-1/4	11-1/4	10-3/8
16	4-1/2	4-1/2	5-1/2	3-13/16	8-1/8	7-3/4	2-1/4	11-1/4	10-3/8
	5	5	5-1/2	3-13/16	8-1/8	8-3/8	2-1/4	11-1/4	10-3/8
	5-1/2	5-1/2	5-1/2	3-13/16	8-1/8	9	2-1/4	11-1/4	10-3/8
	2-1/2	3	5-7/8	3-15/16	9-1/4	4-5/8	2-1/4	12-1/2	11-1/2
	3	3-1/2	5-7/8	3-15/16	9-1/4	5-1/2	2-1/4	12-1/2	11-1/2
	3-1/2	3-1/2	5-7/8	3-15/16	9-1/4	6-1/8	2-1/4	12-1/2	11-1/2
	4	4	5-7/8	3-15/16	9-1/4	6-7/8	2-1/4	12-1/2	11-1/2
18	4-1/2	4-1/2	5-7/8	3-15/16	9-1/4	7-3/4	2-1/4	12-1/2	11-1/2
	5	5	5-7/8	3-15/16	9-1/4	8-3/8	2-1/4	12-1/2	11-1/2
	5-1/2	5-1/2	5-7/8	3-15/16	9-1/4	9	2-1/4	12-1/2	11-1/2
	3-1/2	3-1/2	6	4-3/8	10-1/4	6-1/8	2-1/4	13-5/8	12-1/2
	4	4	6	4-3/8	10-1/4	6-7/8	2-1/4	13-5/8	12-1/2
20	4-1/2	4-1/2	6	4-3/8	10-1/4	7-3/4	2-1/4	13-5/8	12-1/2
	5	5	6	4-3/8	10-1/4	8-3/8	2-1/4	13-5/8	12-1/2
	5-1/2	5-1/2	6	4-3/8	10-1/4	9	2-1/4	13-5/8	12-1/2
	4	4	7-1/8	4-9/16	11-3/4	6-7/8	2-1/4	15-1/4	14
20	4-1/2	4-1/2	7-1/8	4-9/16	11-3/4	7-3/4	2-1/4	15-1/4	14
	5	5	7-1/8	4-9/16	11-3/4	8-3/8	2-1/4	15-1/4	14
	5-1/2	5-1/2	7-1/8	4-9/16	11-3/4	9	2-1/4	15-1/4	14

**MODEL A (NFPA STD. MS2) ▲**

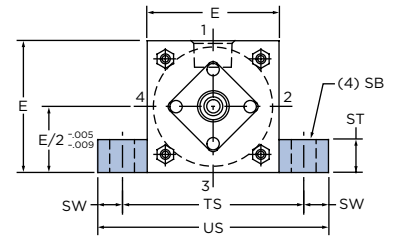
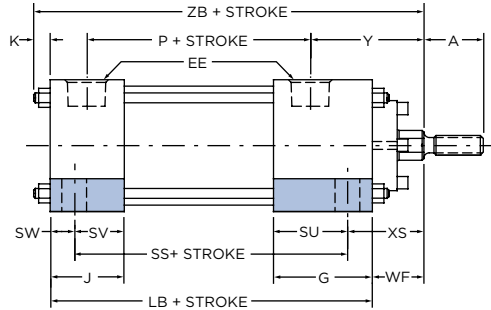
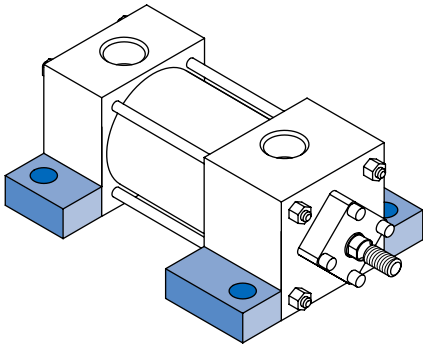

**MODEL B (NFPA STD. MS3) ▲**

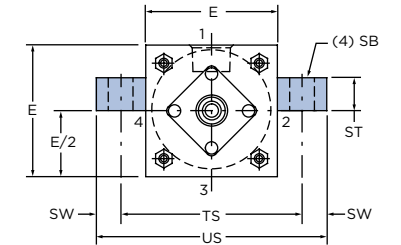
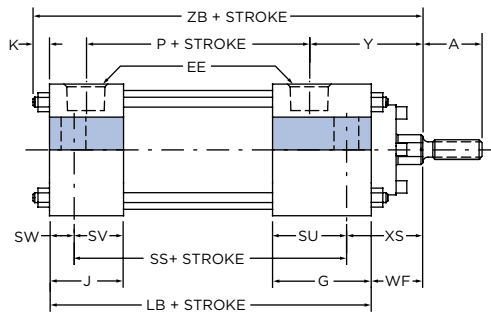
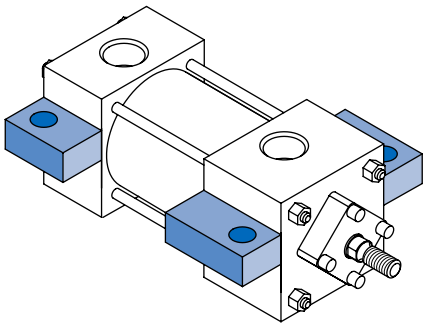

**MODEL S (NFPA STD. MS4) ▲**

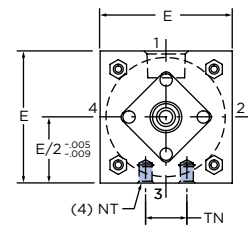
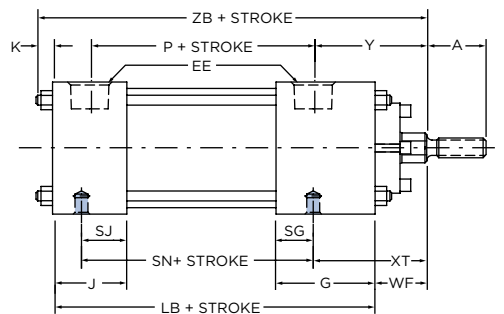
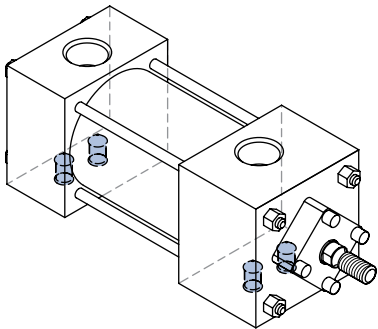

▲ = See Table A on page 127 for bore and rod combinations using head plates with threaded bronze glands.



# SIDE AND LUG MOUNT CYLINDERS

1-1/2" THROUGH 6" BORE

**Table 1** These dimensions are constant regardless of rod diameter or stroke.

For double rod end cylinders Model A and B 1-1/2" through 6" bore: add 1/2" to dimension SS. See pages 128-131.

Double rod end models are designated by letter "X" preceding the model identification. See page 128.

• = Dimensions refer to bolt diameter.

BORE DIA.	E	G	J	K	EE	NT	SB•	SG	SJ	ST	SU	SV	SW	TN	TS	US
1-1/2	2	1-1/2	1-1/8	1/4	3/8	1/4-20	3/8	9/16	11/16	1/2	1-1/8	3/4	3/8	5/8	2-3/4	3-1/2
2	2-1/2	1-1/2	1-1/8	3/8	3/8	5/16-18	3/8	9/16	11/16	1/2	1-1/8	3/4	3/8	7/8	3-1/4	4
2-1/2	3	1-1/2	1-1/8	3/8	3/8	3/8-16	3/8	9/16	11/16	1/2	1-1/8	3/4	3/8	1-1/4	3-3/4	4-1/2
3-1/4	3-3/4	1-3/4	1-1/4	7/16	1/2	1/2-13	1/2	11/16	11/16	3/4	1-1/4	3/4	1/2	1-1/2	4-3/4	5-3/4
4	4-1/2	1-3/4	1-1/4	7/16	1/2	1/2-13	1/2	11/16	11/16	3/4	1-1/4	3/4	1/2	2-1/16	5-1/2	6-1/2
5	5-1/2	1-3/4	1-1/4	1/2	1/2	5/8-11	3/4	11/16	11/16	1	1-1/16	9/16	1-1/16	2-11/16	6-7/8	8-1/4
6	6-1/2	2	1-1/2	9/16	3/4	3/4-10	3/4	13/16	13/16	1	1-5/16	13/16	1-1/16	3-1/4	7-7/8	9-1/4

**Table 2** The dimensions given on this table are affected by the piston rod diameter and the stroke.

For double rod end cylinders Model S 1-1/2" through 2-1/2" bore: add 0.13" to dimension SN. See pages 128-131.

• = For piston rod dimensions see page 132.

BORE DIA.	ROD MM•	A	P	Y	LB	SN	SS	WF	XS	XT	ZB
1-1/2	5/8	3/4	2-1/8	1-15/16	3-5/8	2-1/4	2-7/8	1	1-3/8	1-15/16	4-7/8
	1	1-1/8	2-1/8	2-5/16	3-5/8	2-1/4	2-7/8	1-3/8	1-3/4	2-5/16	5-1/4
2	5/8	3/4	2-1/8	1-15/16	3-5/8	2-1/4	2-7/8	1	1-3/8	1-15/16	5
	1	1-1/8	2-1/8	2-5/16	3-5/8	2-1/4	2-7/8	1-3/8	1-3/4	2-5/16	5-3/8
	1-3/8	1-5/8	2-1/8	2-9/16	3-5/8	2-1/4	2-7/8	1-5/8	2	2-9/16	5-11/16
2-1/2	5/8	3/4	2-1/4	1-15/16	3-3/4	2-3/8	3	1	1-3/8	1-15/16	5-1/16
	1	1-1/8	2-1/4	2-5/16	3-3/4	2-3/8	3	1-3/8	1-3/4	2-5/16	5-7/16
	1-3/8	1-5/8	2-1/4	2-9/16	3-3/4	2-3/8	3	1-5/8	2	2-9/16	5-11/16
	1-3/4	2	2-1/4	2-13/16	3-3/4	2-3/8	3	1-7/8	2-1/4	2-13/16	5-15/16
3-1/4	1	1-1/8	2-1/2	2-1/2	4-1/4	2-5/8	3-1/4	1-3/8	1-7/8	2-7/16	6-1/16
	1-3/8	1-5/8	2-1/2	2-3/4	4-1/4	2-5/8	3-1/4	1-5/8	2-1/8	2-11/16	6-5/16
	1-3/4	2	2-1/2	3	4-1/4	2-5/8	3-1/4	1-7/8	2-3/8	2-15/16	6-9/16
	2	2-1/4	2-1/2	3-1/8	4-1/4	2-5/8	3-1/4	2	2-1/2	3-1/16	6-11/16
4	1	1-1/8	2-1/2	2-1/2	4-1/4	2-5/8	3-1/4	1-3/8	1-7/8	2-7/16	6-1/16
	1-3/8	1-5/8	2-1/2	2-3/4	4-1/4	2-5/8	3-1/4	1-5/8	2-1/8	2-11/16	6-5/16
	1-3/4	2	2-1/2	3	4-1/4	2-5/8	3-1/4	1-7/8	2-3/8	2-15/16	6-9/16
	2	2-1/4	2-1/2	3-1/8	4-1/4	2-5/8	3-1/4	2	2-1/2	3-1/16	6-11/16
	2-1/2	3	2-1/2	3-3/8	4-1/4	2-5/8	3-1/4	2-1/4	2-3/4	3-5/16	6-15/16
5	1	1-1/8	2-3/4	2-1/2	4-1/2	2-7/8	3-1/8	1-3/8	2-1/16	2-7/16	6-3/8
	1-3/8	1-5/8	2-3/4	2-3/4	4-1/2	2-7/8	3-1/8	1-5/8	2-5/16	2-11/16	6-5/8
	1-3/4	2	2-3/4	3	4-1/2	2-7/8	3-1/8	1-7/8	2-9/16	2-15/16	6-7/8
	2	2-1/4	2-3/4	3-1/8	4-1/2	2-7/8	3-1/8	2	2-11/16	3-1/16	7
	2-1/2	3	2-3/4	3-3/8	4-1/2	2-7/8	3-1/8	2-1/4	2-15/16	3-5/16	7-1/4
	3	3-1/2	2-3/4	3-3/8	4-1/2	2-7/8	3-1/8	2-1/4	2-15/16	3-5/16	7-1/4
	3-1/2	3-1/2	2-3/4	3-3/8	4-1/2	2-7/8	3-1/8	2-1/4	2-15/16	3-5/16	7-1/4
6	1-3/8	1-5/8	3-1/8	2-13/16	5	3-1/8	3-5/8	1-5/8	2-5/16	2-13/16	7-3/16
	1-3/4	2	3-1/8	3-1/16	5	3-1/8	3-5/8	1-7/8	2-9/16	3-1/16	7-7/16
	2	2-1/4	3-1/8	3-3/16	5	3-1/8	3-5/8	2	2-11/16	3-3/16	7-9/16
	2-1/2	3	3-1/8	3-7/16	5	3-1/8	3-5/8	2-1/4	2-15/16	3-7/16	7-13/16
	3	3-1/2	3-1/8	3-7/16	5	3-1/8	3-5/8	2-1/4	2-15/16	3-7/16	7-13/16
	3-1/2	3-1/2	3-1/8	3-7/16	5	3-1/8	3-5/8	2-1/4	2-15/16	3-7/16	7-13/16
	4	4	3-1/8	3-7/16	5	3-1/8	3-5/8	2-1/4	2-15/16	3-7/16	7-13/16

**MODEL A (NFPA STD. MS2)**

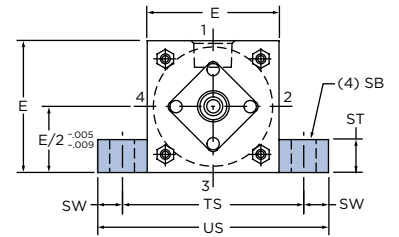
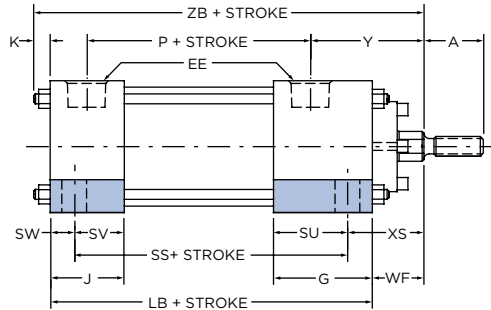
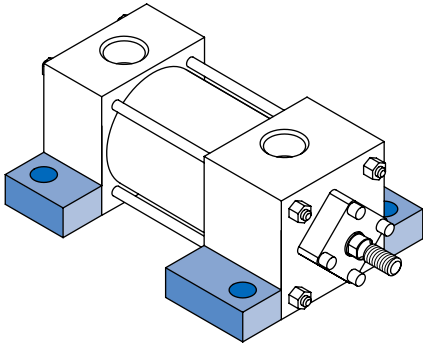

**MODEL B (NFPA STD. MS3)**

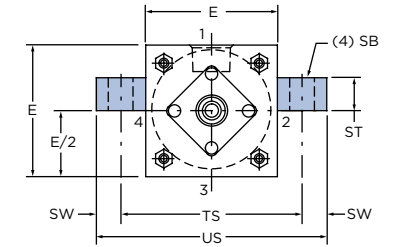
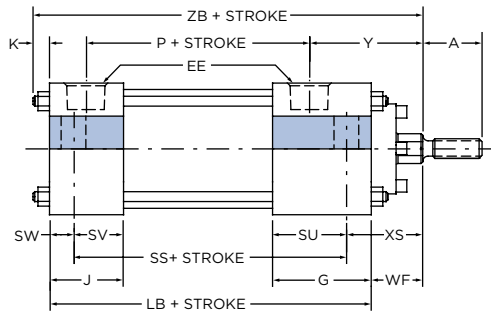
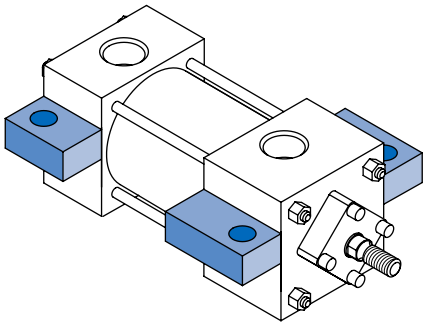

**MODEL S (NFPA STD. MS4)**

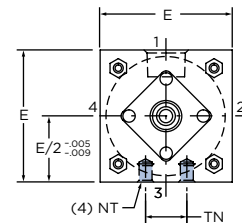
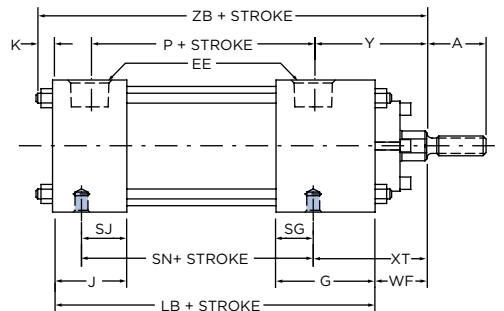
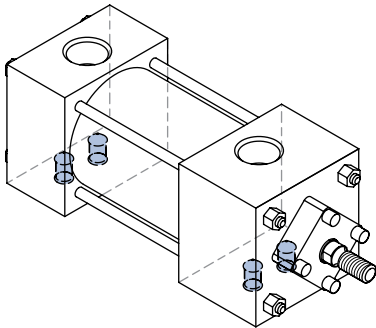

**Table 1** These dimensions are constant regardless of rod diameter or stroke.

For double rod end cylinders Model A and B 8" through 14" bore: subtract dimension SV from dimension SS and add dimension SU. See pages 128-131.

Double rod end models are designated by letter "X" preceding the model identification. See page 128.

• = Dimensions refer to bolt diameter.

BORE DIA.	E	G	J	K	EE	NT	SB•	SG	SJ	ST	SU	SV	SW	TN	TS	US
8	8-1/2	2	1-1/2	5/8	3/4	3/4-10	3/4	13/16	13/16	1	1-5/16	13/16	11/16	4-1/2	9-7/8	11-1/4
10	10-5/8	2-1/4	2	3/4	1	1-8	1	1	1	1-1/4	1-3/8	1-1/8	7/8	5-1/2	12-3/8	14-1/8
12	12-3/4	2-1/4	2	3/4	1	1-8	1	1	1	1-1/4	1-3/8	1-1/8	7/8	7-1/4	14-1/2	16-1/4
14	14-3/4	2-3/4	2-1/4	7/8	1-1/4	1-1/4-7	1-1/4	1-3/16	1-3/16	1-1/2	1-5/8	1-1/8	1-1/8	8-3/8	17	19-1/4
16	17-1/2	3	3	1	1-1/2	1-3/4-12	1-3/4	1-9/16	1-11/16	2	1-1/4	1-1/4	1-5/8	7	21	24-1/4
18	19-1/2	3-7/16	3-7/16	1-1/8	1-1/2	2-12	2	1-3/4	1-7/8	2-1/2	1-7/16	1-7/16	2	8	23-1/2	27-1/2
20	21-3/4	3-15/16	3-15/16	1-1/4	2	2-1/4-12	2-1/4	2	1-7/8	3	1-9/16	1-9/16	2-3/8	8-1/2	26-1/2	31-1/4

# SIDE AND LUG MOUNT CYLINDERS

8" THROUGH 20" BORE

**Table 2** The dimensions given on this table are affected by the piston rod diameter and the stroke.

For double rod end cylinders Model S 16" through 20" bore: subtract dimension SJ from dimension SN and add dimension SG. See pages 128-131.  
• = For piston rod dimensions see page 132.

BORE DIA.	ROD MM•	A	P	Y	LB	SN	SS	WF	XS	XT	ZB
8	1-3/8	1-5/8	3-1/4	2-13/16	5-1/8	3-1/4	3-3/4	1-5/8	2-5/16	2-13/16	7-3/8
	1-3/4	2	3-1/4	3-1/16	5-1/8	3-1/4	3-3/4	1-7/8	2-9/16	3-1/16	7-5/8
	2	2-1/4	3-1/4	3-3/16	5-1/8	3-1/4	3-3/4	2	2-11/16	3-3/16	7-3/4
	2-1/2	3	3-1/4	3-7/16	5-1/8	3-1/4	3-3/4	2-1/4	2-15/16	3-7/16	8
	3	3-1/2	3-1/4	3-7/16	5-1/8	3-1/4	3-3/4	2-1/4	2-15/16	3-7/16	8
	3-1/2	3-1/2	3-1/4	3-7/16	5-1/8	3-1/4	3-3/4	2-1/4	2-15/16	3-7/16	8
	4	4	3-1/4	3-7/16	5-1/8	3-1/4	3-3/4	2-1/4	2-15/16	3-7/16	8
	4-1/2	4-1/2	3-1/4	3-7/16	5-1/8	3-1/4	3-3/4	2-1/4	2-15/16	3-7/16	8
	5	5	3-1/4	3-7/16	5-1/8	3-1/4	3-3/4	2-1/4	2-15/16	3-7/16	8
5-1/2	5-1/2	3-1/4	3-7/16	5-1/8	3-1/4	3-3/4	2-1/4	2-15/16	3-7/16	8	
10	1-3/4	2	4	3-3/16	6-3/8	4-1/8	4-5/8	1-7/8	2-3/4	3-1/8	9
	2	2-1/4	4	3-5/16	6-3/8	4-1/8	4-5/8	2	2-7/8	3-1/4	9-1/8
	2-1/2	3	4	3-9/16	6-3/8	4-1/8	4-5/8	2-1/4	3-1/8	3-1/2	9-3/8
	3	3-1/2	4	3-9/16	6-3/8	4-1/8	4-5/8	2-1/4	3-1/8	3-1/2	9-3/8
	3-1/2	3-1/2	4	3-9/16	6-3/8	4-1/8	4-5/8	2-1/4	3-1/8	3-1/2	9-3/8
	4	4	4	3-9/16	6-3/8	4-1/8	4-5/8	2-1/4	3-1/8	3-1/2	9-3/8
	4-1/2	4-1/2	4	3-9/16	6-3/8	4-1/8	4-5/8	2-1/4	3-1/8	3-1/2	9-3/8
	5	5	4	3-9/16	6-3/8	4-1/8	4-5/8	2-1/4	3-1/8	3-1/2	9-3/8
	5-1/2	5-1/2	4	3-9/16	6-3/8	4-1/8	4-5/8	2-1/4	3-1/8	3-1/2	9-3/8
12	2	2-1/4	4-1/2	3-5/16	6-7/8	4-5/8	5-1/8	2	2-7/8	3-1/4	9-5/8
	2-1/2	3	4-1/2	3-9/16	6-7/8	4-5/8	5-1/8	2-1/4	3-1/8	3-1/2	9-7/8
	3	3-1/2	4-1/2	3-9/16	6-7/8	4-5/8	5-1/8	2-1/4	3-1/8	3-1/2	9-7/8
	3-1/2	3-1/2	4-1/2	3-9/16	6-7/8	4-5/8	5-1/8	2-1/4	3-1/8	3-1/2	9-7/8
	4	4	4-1/2	3-9/16	6-7/8	4-5/8	5-1/8	2-1/4	3-1/8	3-1/2	9-7/8
	4-1/2	4-1/2	4-1/2	3-9/16	6-7/8	4-5/8	5-1/8	2-1/4	3-1/8	3-1/2	9-7/8
	5	5	4-1/2	3-9/16	6-7/8	4-5/8	5-1/8	2-1/4	3-1/8	3-1/2	9-7/8
	5-1/2	5-1/2	4-1/2	3-9/16	6-7/8	4-5/8	5-1/8	2-1/4	3-1/8	3-1/2	9-7/8
	2-1/2	3	5-1/2	3-13/16	8-1/8	5-1/2	5-7/8	2-1/4	3-3/8	3-13/16	11-1/4
14	3	3-1/2	5-1/2	3-13/16	8-1/8	5-1/2	5-7/8	2-1/4	3-3/8	3-13/16	11-1/4
	3-1/2	3-1/2	5-1/2	3-13/16	8-1/8	5-1/2	5-7/8	2-1/4	3-3/8	3-13/16	11-1/4
	4	4	5-1/2	3-13/16	8-1/8	5-1/2	5-7/8	2-1/4	3-3/8	3-13/16	11-1/4
	4-1/2	4-1/2	5-1/2	3-13/16	8-1/8	5-1/2	5-7/8	2-1/4	3-3/8	3-13/16	11-1/4
	5	5	5-1/2	3-13/16	8-1/8	5-1/2	5-7/8	2-1/4	3-3/8	3-13/16	11-1/4
	5-1/2	5-1/2	5-1/2	3-13/16	8-1/8	5-1/2	5-7/8	2-1/4	3-3/8	3-13/16	11-1/4
	2-1/2	3	5-7/8	3-15/16	9-1/4	6-1/2	5-3/4	2-1/4	4	3-11/16	12-1/2
16	3	3-1/2	5-7/8	3-15/16	9-1/4	6-1/2	5-3/4	2-1/4	4	3-11/16	12-1/2
	3-1/2	3-1/2	5-7/8	3-15/16	9-1/4	6-1/2	5-3/4	2-1/4	4	3-11/16	12-1/2
	4	4	5-7/8	3-15/16	9-1/4	6-1/2	5-3/4	2-1/4	4	3-11/16	12-1/2
	4-1/2	4-1/2	5-7/8	3-15/16	9-1/4	6-1/2	5-3/4	2-1/4	4	3-11/16	12-1/2
	5	5	5-7/8	3-15/16	9-1/4	6-1/2	5-3/4	2-1/4	4	3-11/16	12-1/2
	5-1/2	5-1/2	5-7/8	3-15/16	9-1/4	6-1/2	5-3/4	2-1/4	4	3-11/16	12-1/2
	3-1/2	3-1/2	6	4-3/8	10-1/4	7	6-1/4	2-1/4	4-1/4	3-15/16	13-5/8
18	4	4	6	4-3/8	10-1/4	7	6-1/4	2-1/4	4-1/4	3-15/16	13-5/8
	4-1/2	4-1/2	6	4-3/8	10-1/4	7	6-1/4	2-1/4	4-1/4	3-15/16	13-5/8
	5	5	6	4-3/8	10-1/4	7	6-1/4	2-1/4	4-1/4	3-15/16	13-5/8
	5-1/2	5-1/2	6	4-3/8	10-1/4	7	6-1/4	2-1/4	4-1/4	3-15/16	13-5/8
	4	4	7-1/8	4-9/16	11-3/4	7-3/4	7	2-1/4	4-5/8	4-3/16	15-1/4
20	4-1/2	4-1/2	7-1/8	4-9/16	11-3/4	7-3/4	7	2-1/4	4-5/8	4-3/16	15-1/4
	5	5	7-1/8	4-9/16	11-3/4	7-3/4	7	2-1/4	4-5/8	4-3/16	15-1/4
	5-1/2	5-1/2	7-1/8	4-9/16	11-3/4	7-3/4	7	2-1/4	4-5/8	4-3/16	15-1/4

**MODEL AL (NFPA STD. MS7)**

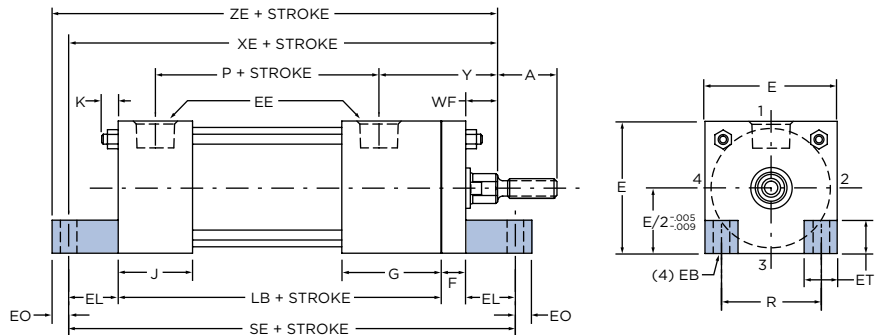
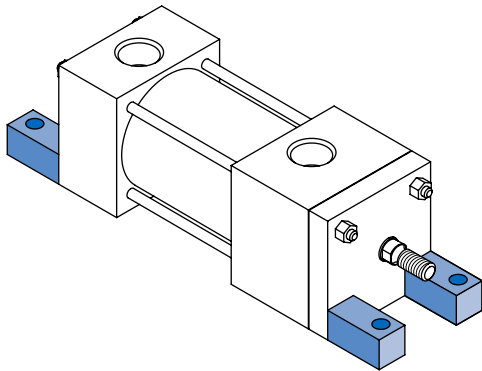

Model AL 1-1/2" diameter through 6" diameter cylinders furnished with head plates. 8" diameter through 14" diameter cylinders use (4) bolt glands as shown on page 110.

**MODEL E (NFPA STD. MP1)▲**

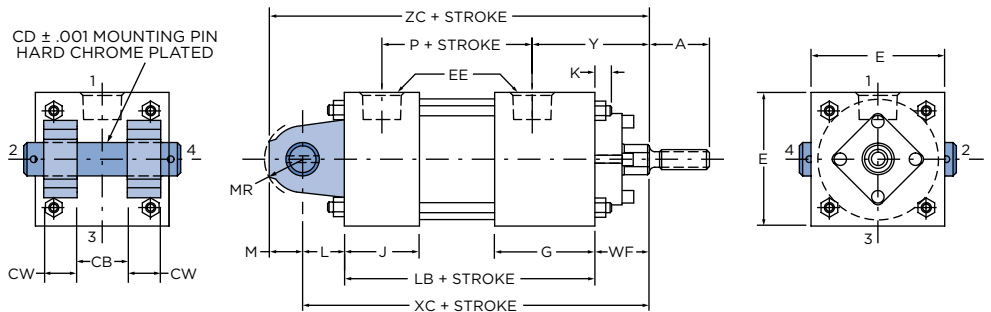
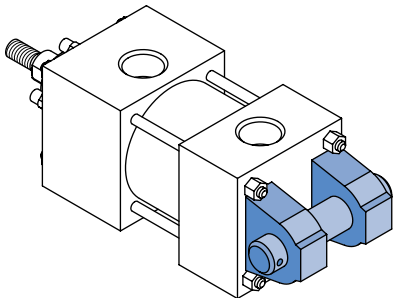

**MODEL HE (NFPA STD. MP2)▲**

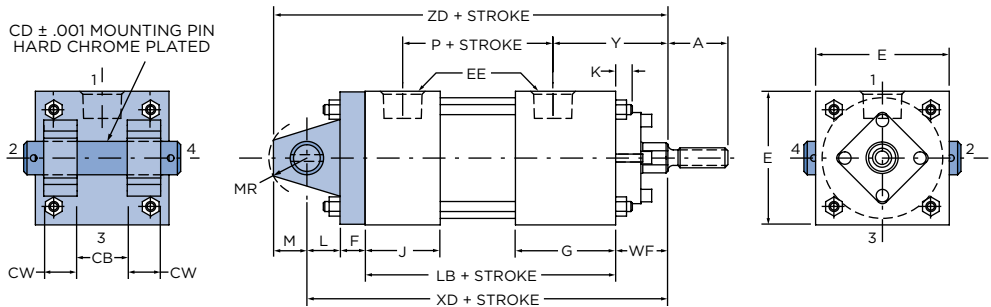
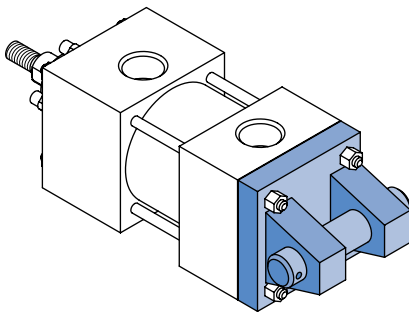

▲ = See Table A on page 127 for bore and rod combinations using head plates with threaded bronze glands.

**Table 1** These dimensions are constant regardless of rod diameter or stroke.

For double rod end cylinders Model AL: subtract dimension J from dimension G and add to dimension SE + stroke.

For 1-1/2" through 6" bore: also add dimension F. See pages 128-131.

Double rod end models are designated by letter "X" preceding the model identification. See page 128.

• = Dimensions refer to bolt diameter.

BORE DIA.	E	F		G	J	K	L	M	R	CB	CD	CW	EB•	EE	EL	EO	ET	MR
		AL	HE															
1-1/2	2	3/8	3/8	1-1/2	1-1/8	1/4	3/4	1/2	1.43	3/4	1/2	1/2	1/4	3/8	3/4	1/4	1/2	5/8
2	2-1/2	3/8	3/8	1-1/2	1-1/8	3/8	3/4	1/2	1.84	3/4	1/2	1/2	5/16	3/8	15/16	5/16	19/32	5/8
2-1/2	3	3/8	3/8	1-1/2	1-1/8	5/16	3/4	1/2	2.19	3/4	1/2	1/2	5/16	3/8	1-1/16	5/16	3/4	5/8
3-1/4	3-3/4	5/8	5/8	1-3/4	1-1/4	7/16	1-1/4	3/4	2.76	1-1/4	3/4	5/8	3/8	1/2	7/8	3/8	29/32	7/8
4	4-1/2	5/8	5/8	1-3/4	1-1/4	7/16	1-1/4	3/4	3.32	1-1/4	3/4	5/8	3/8	1/2	1	3/8	1-1/8	7/8
5	5-1/2	5/8	5/8	1-3/4	1-1/4	1/2	1-1/4	3/4	4.1	1-1/4	3/4	5/8	1/2	1/2	1-1/16	1/2	1-11/32	7/8
6	6-1/2	3/4	7/8	2	1-1/2	9/16	1-1/2	1	4.88	1-1/2	1	3/4	1/2	3/4	1	1/2	1-9/16	1-1/4
8	8-1/2	3/4	7/8	2	1-1/2	5/8	1-1/2	1	6.44	1-1/2	1	3/4	5/8	3/4	1-1/8	5/8	2	1-1/4

# END LUG AND CLEVIS MOUNT CYLINDERS

1-1/2" THROUGH 8" DIAMETER

**Table 2** The dimensions given on this table are affected by the piston rod diameter and the stroke.

• = For piston rod dimensions see page 132.

BORE DIA.	ROD MM•	A	P	W	Y	LB	SE	WF	XC	XD	XE	ZC	ZD	ZE
1-1/2	5/8	3/4	2-1/8	5/8	1-15/16	3-5/8	5-1/2	1	5-3/8	5-3/4	5-3/8	5-7/8	6-1/4	5-5/8
	1	1-1/8	2-1/8	1	2-5/16	3-5/8	5-1/2	1-3/8	5-3/4	6-1/8	5-3/4	6-1/4	6-5/8	6
2	5/8	3/4	2-1/8	5/8	1-15/16	3-5/8	5-7/8	1	5-3/8	5-3/4	5-9/16	5-7/8	6-1/4	5-7/8
	1	1-1/8	2-1/8	1	2-5/16	3-5/8	5-7/8	1-3/8	5-3/4	6-1/8	5-15/16	6-1/4	6-5/8	6-1/4
	1-3/8	1-5/8	2-1/8	1-1/4	2-9/16	3-5/8	5-7/8	1-5/8	6	6-3/8	6-3/16	6-1/2	6-7/8	6-1/2
2-1/2	5/8	3/4	2-1/4	5/8	1-15/16	3-3/4	6-1/4	1	5-1/2	5-7/8	5-13/16	6	6-3/8	6-1/8
	1	1-1/8	2-1/4	1	2-5/16	3-3/4	6-1/4	1-3/8	5-7/8	6-1/4	6-3/16	6-3/8	6-3/4	6-1/2
	1-3/8	1-5/8	2-1/4	1-1/4	2-9/16	3-3/4	6-1/4	1-5/8	6-1/8	6-1/2	6-7/16	6-5/8	7	6-3/4
	1-3/4	2	2-1/4	1-1/2	2-13/16	3-3/4	6-1/4	1-7/8	6-3/8	6-3/4	6-11/16	6-7/8	7-1/4	7
3-1/4	1	1-1/8	2-1/2	3/4	2-1/2	4-1/4	6-5/8	1-3/8	6-7/8	7-1/2	6-1/2	7-5/8	8-1/4	6-7/8
	1-3/8	1-5/8	2-1/2	1	2-3/4	4-1/4	6-5/8	1-5/8	7-1/8	7-3/4	6-3/4	7-7/8	8-1/2	7-1/8
	1-3/4	2	2-1/2	1-1/4	3	4-1/4	6-5/8	1-7/8	7-3/8	8	7	8-1/8	8-3/4	7-3/8
	2	2-1/4	2-1/2	1-3/8	3-1/8	4-1/4	6-5/8	2	7-1/2	8-1/8	7-1/8	8-1/4	8-7/8	7-1/2
4	1	1-1/8	2-1/2	3/4	2-1/2	4-1/4	6-7/8	1-3/8	6-7/8	7-1/2	6-5/8	7-5/8	8-1/4	7
	1-3/8	1-5/8	2-1/2	1	2-3/4	4-1/4	6-7/8	1-5/8	7-1/8	7-3/4	6-7/8	7-7/8	8-1/2	7-1/4
	1-3/4	2	2-1/2	1-1/4	3	4-1/4	6-7/8	1-7/8	7-3/8	8	7-1/8	8-1/8	8-3/4	7-1/2
	2	2-1/4	2-1/2	1-3/8	3-1/8	4-1/4	6-7/8	2	7-1/2	8-1/8	7-1/4	8-1/4	8-7/8	7-5/8
	2-1/2	3	2-1/2	1-5/8	3-3/8	4-1/4	6-7/8	2-1/4	7-3/4	8-3/8	7-1/2	8-1/2	9-1/8	7-7/8
5	1	1-1/8	2-3/4	3/4	2-1/2	4-1/2	7-1/4	1-3/8	7-1/8	7-3/4	6-15/16	7-7/8	8-1/2	7-7/16
	1-3/8	1-5/8	2-3/4	1	2-3/4	4-1/2	7-1/4	1-5/8	7-3/8	8	7-3/16	8-1/8	8-3/4	7-11/16
	1-3/4	2	2-3/4	1-1/4	3	4-1/2	7-1/4	1-7/8	7-5/8	8-1/4	7-7/16	8-3/8	9	7-15/16
	2	2-1/4	2-3/4	1-3/8	3-1/8	4-1/2	7-1/4	2	7-3/4	8-3/8	7-9/16	8-1/2	9-1/8	8-1/16
	2-1/2	3	2-3/4	1-5/8	3-3/8	4-1/2	7-1/4	2-1/4	8	8-5/8	7-13/16	8-3/4	9-3/8	8-5/16
	3	3-1/2	2-3/4	1-5/8	3-3/8	4-1/2	7-1/4	2-1/4	8	8-5/8	7-13/16	8-3/4	9-3/8	8-5/16
	3-1/2	3-1/2	2-3/4	1-5/8	3-3/8	4-1/2	7-1/4	2-1/4	8	8-5/8	7-13/16	8-3/4	9-3/8	8-5/16
6	1-3/8	1-5/8	3-1/8	7/8	2-13/16	5	7-3/4	1-5/8	8-1/8	9	7-5/8	9-1/8	10	8-1/8
	1-3/4	2	3-1/8	1-1/8	3-1/16	5	7-3/4	1-7/8	8-3/8	9-1/4	7-7/8	9-3/8	10-1/4	8-3/8
	2	2-1/4	3-1/8	1-1/4	3-3/16	5	7-3/4	2	8-1/2	9-3/8	8	9-1/2	10-3/8	8-1/2
	2-1/2	3	3-1/8	1-1/2	3-7/16	5	7-3/4	2-1/4	8-3/4	9-5/8	8-1/4	9-3/4	10-5/8	8-3/4
	3	3-1/2	3-1/8	1-1/2	3-7/16	5	7-3/4	2-1/4	8-3/4	9-5/8	8-1/4	9-3/4	10-5/8	8-3/4
	3-1/2	3-1/2	3-1/8	1-1/2	3-7/16	5	7-3/4	2-1/4	8-3/4	9-5/8	8-1/4	9-3/4	10-5/8	8-3/4
8	4	4	3-1/8	1-1/2	3-7/16	5	7-3/4	2-1/4	8-3/4	9-5/8	8-1/4	9-3/4	10-5/8	8-3/4
	1-3/8	1-5/8	3-1/4	-	2-13/16	5-1/8	7-3/8	1-5/8	8-1/4	9-1/8	7-7/8	9-1/4	10-1/8	8-1/2
	1-3/4	2	3-1/4	-	3-1/16	5-1/8	7-3/8	1-7/8	8-1/2	9-3/8	8-1/8	9-1/2	10-3/8	8-3/4
	2	2-1/4	3-1/4	-	3-3/16	5-1/8	7-3/8	2	8-5/8	9-1/2	8-1/4	9-5/8	10-1/2	8-7/8
	2-1/2	3	3-1/4	-	3-7/16	5-1/8	7-3/8	2-1/4	8-7/8	9-3/4	8-1/2	9-7/8	10-3/4	9-1/8
	3	3-1/2	3-1/4	-	3-7/16	5-1/8	7-3/8	2-1/4	8-7/8	9-3/4	8-1/2	9-7/8	10-3/4	9-1/8
	3-1/2	3-1/2	3-1/4	-	3-7/16	5-1/8	7-3/8	2-1/4	8-7/8	9-3/4	8-1/2	9-7/8	10-3/4	9-1/8
	4	4	3-1/4	-	3-7/16	5-1/8	7-3/8	2-1/4	8-7/8	9-3/4	8-1/2	9-7/8	10-3/4	9-1/8
	4-1/2	4-1/2	3-1/4	-	3-7/16	5-1/8	7-3/8	2-1/4	8-7/8	9-3/4	8-1/2	9-7/8	10-3/4	9-1/8
5	5	3-1/4	-	3-7/16	5-1/8	7-3/8	2-1/4	8-7/8	9-3/4	8-1/2	9-7/8	10-3/4	9-1/8	
5-1/2	5-1/2	3-1/4	-	3-7/16	5-1/8	7-3/8	2-1/4	8-7/8	9-3/4	8-1/2	9-7/8	10-3/4	9-1/8	

**MODEL AL (NFPA STD. MS7) 10" THROUGH 14" DIAMETER**

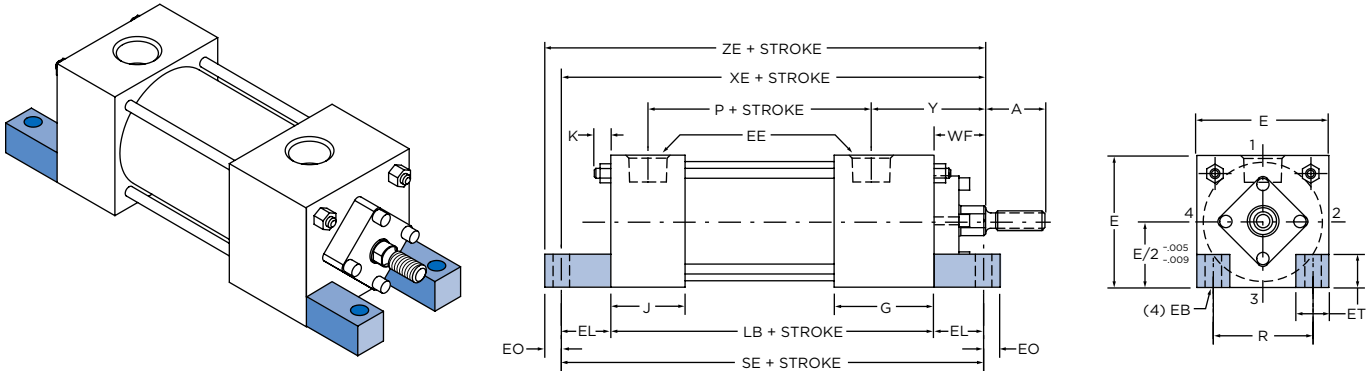

**MODEL E (NFPA STD. MP1) 10" THROUGH 20" DIAMETER**

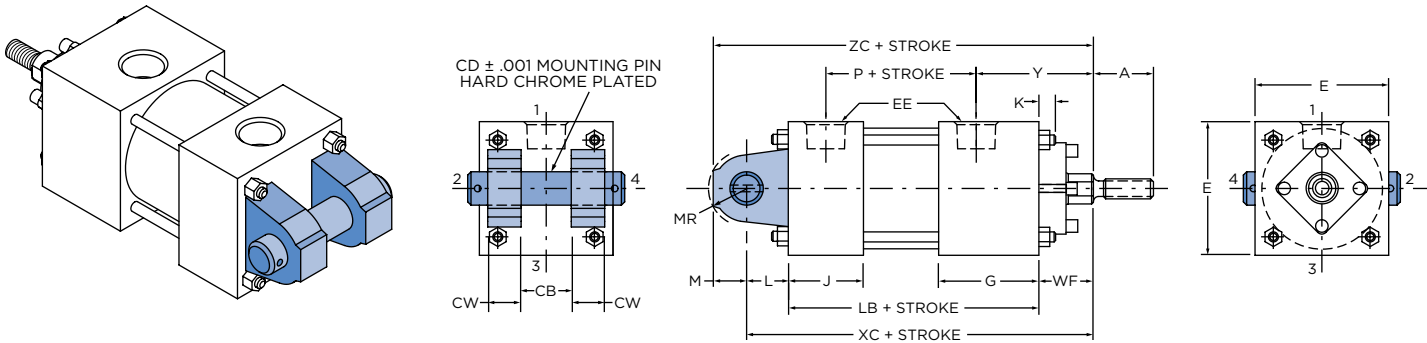

**MODEL HE (NFPA STD. MP2) 10" DIAMETER**

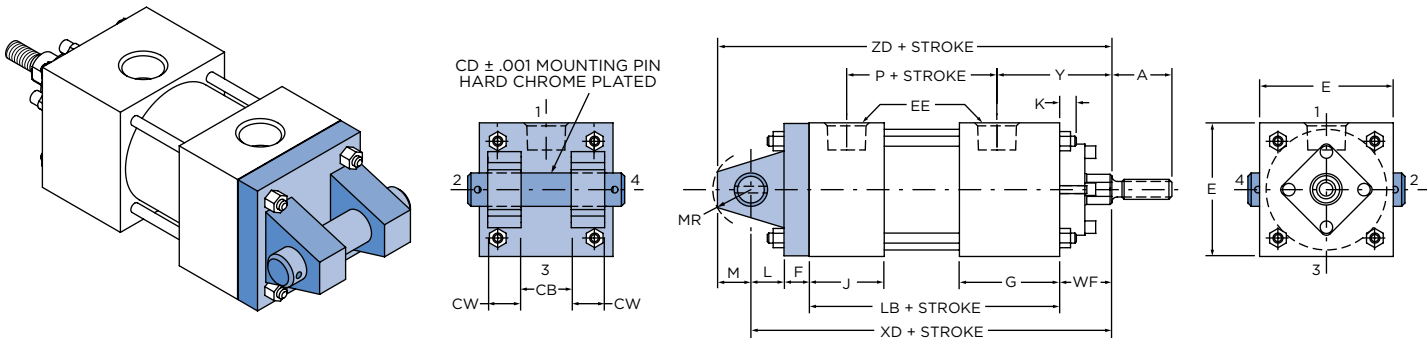

**Table 1** These dimensions are constant regardless of rod diameter or stroke.

For double rod end cylinders Model AL: subtract dimension J from dimension G and add to dimension SE + stroke. See pages 128-131. Double rod end models are designated by letter "X" preceding the model identification. See page 128.

• = Dimensions refer to bolt diameter.

BORE DIA.	E	F	G	J	K	L	M	R	CB	CD	CW	EB•	EE	EL	EO	ET	MR
10	10-5/8	7/8	2-1/4	2	3/4	2-1/8	1-3/8	7.92	2	1-3/8	1	3/4	1	1-5/16	1-5/16	2-5/8	1-5/8
12	12-3/4	-	2-1/4	2	3/4	2-1/4	1-3/4	9.4	2-1/2	1-3/4	1-1/4	3/4	1	1-5/16	1-11/16	3-3/8	2
14	14-3/4	-	2-3/4	2-1/4	7/8	2-1/2	2	10.9	2-1/2	2	1-1/4	7/8	1-1/4	1-1/2	2	3-7/8	2-3/8
16	17-1/2	-	3	3	1	2-1/2	2	-	2-1/2	2	1-1/4	-	1-1/2	-	-	-	2-3/8
18	19-1/2	-	3-7/16	3-7/16	1-1/8	3	2-3/4	-	3	2-1/2	1-1/2	-	1-1/2	-	-	-	3
20	21-3/4	-	3-15/16	3-15/16	1-1/4	3-1/4	2-3/4	-	3	3	1-1/2	-	2	-	-	-	3-1/4

# END LUG AND CLEVIS MOUNT CYLINDERS

10" THROUGH 20" DIAMETER

**Table 2** The dimensions given on this table are affected by the piston rod diameter and the stroke.

• = For piston rod dimensions see page 132.

BORE DIA.	ROD MM•	A	P	Y	LB	SE	WF	XC	XD	XE	ZC	ZD	ZE
10	1-3/4	2	4	3-3/16	6-3/8	9	1-7/8	10-3/8	11-1/4	9-9/16	11-3/4	12-5/8	10-7/8
	2	2-1/4	4	3-5/16	6-3/8	9	2	10-1/2	11-3/8	9-11/16	11-7/8	12-3/4	11
	2-1/2	3	4	3-9/16	6-3/8	9	2-1/4	10-3/4	11-5/8	9-15/16	12-1/8	13	11-1/4
	3	3-1/2	4	3-9/16	6-3/8	9	2-1/4	10-3/4	11-5/8	9-15/16	12-1/8	13	11-1/4
	3-1/2	3-1/2	4	3-9/16	6-3/8	9	2-1/4	10-3/4	11-5/8	9-15/16	12-1/8	13	11-1/4
	4	4	4	3-9/16	6-3/8	9	2-1/4	10-3/4	11-5/8	9-15/16	12-1/8	13	11-1/4
	4-1/2	4-1/2	4	3-9/16	6-3/8	9	2-1/4	10-3/4	11-5/8	9-15/16	12-1/8	13	11-1/4
	5	5	4	3-9/16	6-3/8	9	2-1/4	10-3/4	11-5/8	9-15/16	12-1/8	13	11-1/4
12	2	2-1/4	4-1/2	3-5/16	6-7/8	9-1/2	2	11-1/8	-	10-3/16	12-7/8	-	11-7/8
	2-1/2	3	4-1/2	3-9/16	6-7/8	9-1/2	2-1/4	11-3/8	-	10-7/16	13-1/8	-	12-1/8
	3	3-1/2	4-1/2	3-9/16	6-7/8	9-1/2	2-1/4	11-3/8	-	10-7/16	13-1/8	-	12-1/8
	3-1/2	3-1/2	4-1/2	3-9/16	6-7/8	9-1/2	2-1/4	11-3/8	-	10-7/16	13-1/8	-	12-1/8
	4	4	4-1/2	3-9/16	6-7/8	9-1/2	2-1/4	11-3/8	-	10-7/16	13-1/8	-	12-1/8
	4-1/2	4-1/2	4-1/2	3-9/16	6-7/8	9-1/2	2-1/4	11-3/8	-	10-7/16	13-1/8	-	12-1/8
	5	5	4-1/2	3-9/16	6-7/8	9-1/2	2-1/4	11-3/8	-	10-7/16	13-1/8	-	12-1/8
14	2-1/2	3	5-1/2	3-13/16	8-1/8	11-1/8	2-1/4	12-7/8	-	11-7/8	14-7/8	-	13-7/8
	3	3-1/2	5-1/2	3-13/16	8-1/8	11-1/8	2-1/4	12-7/8	-	11-7/8	14-7/8	-	13-7/8
	3-1/2	3-1/2	5-1/2	3-13/16	8-1/8	11-1/8	2-1/4	12-7/8	-	11-7/8	14-7/8	-	13-7/8
	4	4	5-1/2	3-13/16	8-1/8	11-1/8	2-1/4	12-7/8	-	11-7/8	14-7/8	-	13-7/8
	4-1/2	4-1/2	5-1/2	3-13/16	8-1/8	11-1/8	2-1/4	12-7/8	-	11-7/8	14-7/8	-	13-7/8
	5	5	5-1/2	3-13/16	8-1/8	11-1/8	2-1/4	12-7/8	-	11-7/8	14-7/8	-	13-7/8
16	2-1/2	3	5-7/8	3-15/16	9-1/4	-	2-1/4	14	-	-	16	-	-
	3	3-1/2	5-7/8	3-15/16	9-1/4	-	2-1/4	14	-	-	16	-	-
	3-1/2	3-1/2	5-7/8	3-15/16	9-1/4	-	2-1/4	14	-	-	16	-	-
	4	4	5-7/8	3-15/16	9-1/4	-	2-1/4	14	-	-	16	-	-
	4-1/2	4-1/2	5-7/8	3-15/16	9-1/4	-	2-1/4	14	-	-	16	-	-
	5	5	5-7/8	3-15/16	9-1/4	-	2-1/4	14	-	-	16	-	-
	5-1/2	5-1/2	5-7/8	3-15/16	9-1/4	-	2-1/4	14	-	-	16	-	-
18	3-1/2	3-1/2	6	4-3/8	10-1/4	-	2-1/4	15-1/2	-	-	18	-	-
	4	4	6	4-3/8	10-1/4	-	2-1/4	15-1/2	-	-	18	-	-
	4-1/2	4-1/2	6	4-3/8	10-1/4	-	2-1/4	15-1/2	-	-	18	-	-
	5	5	6	4-3/8	10-1/4	-	2-1/4	15-1/2	-	-	18	-	-
	5-1/2	5-1/2	6	4-3/8	10-1/4	-	2-1/4	15-1/2	-	-	18	-	-
20	4	4	7-1/8	4-9/16	11-3/4	-	2-1/4	17-1/4	-	-	20	-	-
	4-1/2	4-1/2	7-1/8	4-9/16	11-3/4	-	2-1/4	17-1/4	-	-	20	-	-
	5	5	7-1/8	4-9/16	11-3/4	-	2-1/4	17-1/4	-	-	20	-	-
	5-1/2	5-1/2	7-1/8	4-9/16	11-3/4	-	2-1/4	17-1/4	-	-	20	-	-

**MODEL E3 (NFPA STD. MP3)**

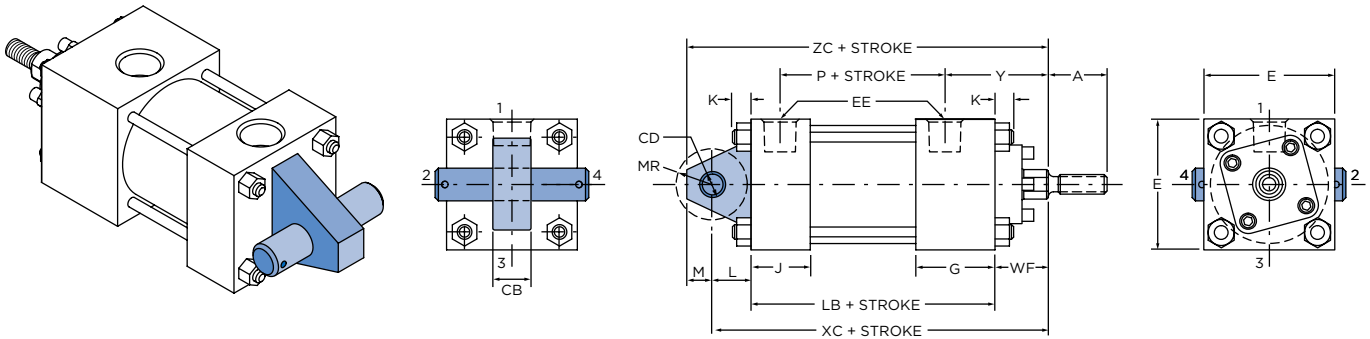

**Table 1** These dimensions are constant regardless of rod diameter or stroke.

BORE DIA.	E	F	G	J	K	L	M	CB	CD	EE	MR
1-1/2	2	3/8	1-1/2	1-1/8	1/4	3/4	1/2	3/4	1/2	3/8	5/8
2	2-1/2	3/8	1-1/2	1-1/8	3/8	3/4	1/2	3/4	1/2	3/8	5/8
2-1/2	3	3/8	1-1/2	1-1/8	5/16	3/4	1/2	3/4	1/2	3/8	5/8
3-1/4	3-3/4	5/8	1-3/4	1-1/4	7/16	1-1/4	3/4	1-1/4	3/4	1/2	7/8
4	4-1/2	5/8	1-3/4	1-1/4	7/16	1-1/4	3/4	1-1/4	3/4	1/2	7/8
5	5-1/2	5/8	1-3/4	1-1/4	1/2	1-1/4	3/4	1-1/4	3/4	1/2	7/8
6	6-1/2	3/4	2	1-1/2	9/16	1-1/2	1	1-1/2	1	3/4	1-1/4
8	8-1/2	3/4	2	1-1/2	5/8	1-1/2	1	1-1/2	1	3/4	1-1/4



# FIXED EYE MOUNT CYLINDERS

1-1/2" THROUGH 8" DIAMETER

**Table 2** The dimensions given on this table are affected by the piston rod diameter and the stroke.

• = For piston rod dimensions see page 132.

BORE DIA.	ROD MM•	A	P	W	Y	LB	WF	XC	ZC
1-1/2	5/8	3/4	2-1/8	5/8	1-15/16	3-5/8	1	5-3/8	5-7/8
	1	1-1/8	2-1/8	1	2-5/16	3-5/8	1-3/8	5-3/4	6-1/4
2	5/8	3/4	2-1/8	5/8	1-15/16	3-5/8	1	5-3/8	5-7/8
	1	1-1/8	2-1/8	1	2-5/16	3-5/8	1-3/8	5-3/4	6-1/4
	1-3/8	1-5/8	2-1/8	1-1/4	2-9/16	3-5/8	1-5/8	6	6-1/2
2-1/2	5/8	3/4	2-1/4	5/8	1-15/16	3-3/4	1	5-1/2	6
	1	1-1/8	2-1/4	1	2-5/16	3-3/4	1-3/8	5-7/8	6-3/8
	1-3/8	1-5/8	2-1/4	1-1/4	2-9/16	3-3/4	1-5/8	6-1/8	6-5/8
	1-3/4	2	2-1/4	1-1/2	2-13/16	3-3/4	1-7/8	6-3/8	6-7/8
3-1/4	1	1-1/8	2-1/2	3/4	2-1/2	4-1/4	1-3/8	6-7/8	7-5/8
	1-3/8	1-5/8	2-1/2	1	2-3/4	4-1/4	1-5/8	7-1/8	7-7/8
	1-3/4	2	2-1/2	1-1/4	3	4-1/4	1-7/8	7-3/8	8-1/8
	2	2-1/4	2-1/2	1-3/8	3-1/8	4-1/4	2	7-1/2	8-1/4
4	1	1-1/8	2-1/2	3/4	2-1/2	4-1/4	1-3/8	6-7/8	7-5/8
	1-3/8	1-5/8	2-1/2	1	2-3/4	4-1/4	1-5/8	7-1/8	7-7/8
	1-3/4	2	2-1/2	1-1/4	3	4-1/4	1-7/8	7-3/8	8-1/8
	2	2-1/4	2-1/2	1-3/8	3-1/8	4-1/4	2	7-1/2	8-1/4
	2-1/2	3	2-1/2	1-5/8	3-3/8	4-1/4	2-1/4	7-3/4	8-1/2
5	1	1-1/8	2-3/4	3/4	2-1/2	4-1/2	1-3/8	7-1/8	7-7/8
	1-3/8	1-5/8	2-3/4	1	2-3/4	4-1/2	1-5/8	7-3/8	8-1/8
	1-3/4	2	2-3/4	1-1/4	3	4-1/2	1-7/8	7-5/8	8-3/8
	2	2-1/4	2-3/4	1-3/8	3-1/8	4-1/2	2	7-3/4	8-1/2
	2-1/2	3	2-3/4	1-5/8	3-3/8	4-1/2	2-1/4	8	8-3/4
	3	3-1/2	2-3/4	1-5/8	3-3/8	4-1/2	2-1/4	8	8-3/4
	3-1/2	3-1/2	2-3/4	1-5/8	3-3/8	4-1/2	2-1/4	8	8-3/4
6	1-3/8	1-5/8	3-1/8	7/8	2-13/16	5	1-5/8	8-1/8	9-1/8
	1-3/4	2	3-1/8	1-1/8	3-1/16	5	1-7/8	8-3/8	9-3/8
	2	2-1/4	3-1/8	1-1/4	3-3/16	5	2	8-1/2	9-1/2
	2-1/2	3	3-1/8	1-1/2	3-7/16	5	2-1/4	8-3/4	9-3/4
	3	3-1/2	3-1/8	1-1/2	3-7/16	5	2-1/4	8-3/4	9-3/4
	3-1/2	3-1/2	3-1/8	1-1/2	3-7/16	5	2-1/4	8-3/4	9-3/4
	4	4	3-1/8	1-1/2	3-7/16	5	2-1/4	8-3/4	9-3/4
8	1-3/8	1-5/8	3-1/4	-	2-13/16	5-1/8	1-5/8	8-1/4	9-1/4
	1-3/4	2	3-1/4	-	3-1/16	5-1/8	1-7/8	8-1/2	9-1/2
	2	2-1/4	3-1/4	-	3-3/16	5-1/8	2	8-5/8	9-5/8
	2-1/2	3	3-1/4	-	3-7/16	5-1/8	2-1/4	8-7/8	9-7/8
	3	3-1/2	3-1/4	-	3-7/16	5-1/8	2-1/4	8-7/8	9-7/8
	3-1/2	3-1/2	3-1/4	-	3-7/16	5-1/8	2-1/4	8-7/8	9-7/8
	4	4	3-1/4	-	3-7/16	5-1/8	2-1/4	8-7/8	9-7/8
	4-1/2	4-1/2	3-1/4	-	3-7/16	5-1/8	2-1/4	8-7/8	9-7/8
	5	5	3-1/4	-	3-7/16	5-1/8	2-1/4	8-7/8	9-7/8
5-1/2	5-1/2	3-1/4	-	3-7/16	5-1/8	2-1/4	8-7/8	9-7/8	

**MODEL E4 (NFPA STD. MP4)**

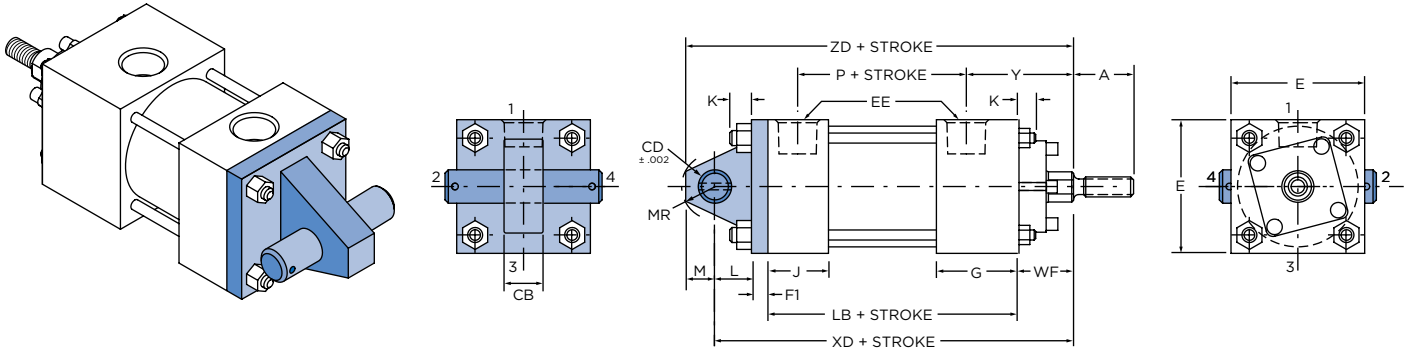

**Table 1** These dimensions are constant regardless of rod diameter or stroke.

BORE DIA.	E	F	G	J	K	L	M	CB	CD	EE	MR
1-1/2	2	3/8	1-1/2	1-1/8	1/4	3/4	1/2	3/4	1/2	3/8	5/8
2	2-1/2	3/8	1-1/2	1-1/8	3/8	3/4	1/2	3/4	1/2	3/8	5/8
2-1/2	3	3/8	1-1/2	1-1/8	3/8	3/4	1/2	3/4	1/2	3/8	5/8
3-1/4	3-3/4	5/8	1-3/4	1-1/4	7/16	1-1/4	3/4	1-1/4	3/4	1/2	7/8
4	4-1/2	5/8	1-3/4	1-1/4	7/16	1-1/4	3/4	1-1/4	3/4	1/2	7/8
5	5-1/2	5/8	1-3/4	1-1/4	1/2	1-1/4	3/4	1-1/4	3/4	1/2	7/8
6	6-1/2	7/8	2	1-1/2	9/16	1-1/2	1	1-1/2	1	3/4	1-1/4
8	8-1/2	7/8	2	1-1/2	5/8	1-1/2	1	1-1/2	1	3/4	1-1/4
10	10-5/8	7/8	2-1/4	2	3/4	2-1/8	1-3/8	2	1-3/8	1	1-5/8

# DETACHABLE EYE MOUNT CYLINDERS

1-1/2" THROUGH 10" DIAMETER

**Table 2** The dimensions given on this table are affected by the piston rod diameter and the stroke.

• = For piston rod dimensions see page 132.

BORE DIA.	ROD MM•	A	P	Y	LB	WF	XD	ZD
1-1/2	5/8	3/4	2-1/8	1-15/16	3-5/8	1	5-3/4	6-1/4
	1	1-1/8	2-1/8	2-5/16	3-5/8	1-3/8	6-1/8	6-5/8
2	5/8	3/4	2-1/8	1-15/16	3-5/8	1	5-3/4	6-1/4
	1	1-1/8	2-1/8	2-5/16	3-5/8	1-3/8	6-1/8	6-5/8
	1-3/8	1-5/8	2-1/8	2-9/16	3-5/8	1-5/8	6-3/8	6-7/8
2-1/2	5/8	3/4	2-1/4	1-15/16	3-3/4	1	5-7/8	6-3/8
	1	1-1/8	2-1/4	2-5/16	3-3/4	1-3/8	6-1/4	6-3/4
	1-3/8	1-5/8	2-1/4	2-9/16	3-3/4	1-5/8	6-1/2	7
	1-3/4	2	2-1/4	2-13/16	3-3/4	1-7/8	6-3/4	7-1/4
3-1/4	1	1-1/8	2-1/2	2-1/2	4-1/4	1-3/8	7-1/2	8-1/4
	1-3/8	1-5/8	2-1/2	2-3/4	4-1/4	1-5/8	7-3/4	8-1/2
	1-3/4	2	2-1/2	3	4-1/4	1-7/8	8	8-3/4
	2	2-1/4	2-1/2	3-1/8	4-1/4	2	8-1/8	8-7/8
4	1	1-1/8	2-1/2	2-1/2	4-1/4	1-3/8	7-1/2	8-1/4
	1-3/8	1-5/8	2-1/2	2-3/4	4-1/4	1-5/8	7-3/4	8-1/2
	1-3/4	2	2-1/2	3	4-1/4	1-7/8	8	8-3/4
	2	2-1/4	2-1/2	3-1/8	4-1/4	2	8-1/8	8-7/8
	2-1/2	3	2-1/2	3-3/8	4-1/4	2-1/4	8-3/8	9-1/8
5	1	1-1/8	2-3/4	2-1/2	4-1/2	1-3/8	7-3/4	8-1/2
	1-3/8	1-5/8	2-3/4	2-3/4	4-1/2	1-5/8	8	8-3/4
	1-3/4	2	2-3/4	3	4-1/2	1-7/8	8-1/4	9
	2	2-1/4	2-3/4	3-1/8	4-1/2	2	8-3/8	9-1/8
	2-1/2	3	2-3/4	3-3/8	4-1/2	2-1/4	8-5/8	9-3/8
	3	3-1/2	2-3/4	3-3/8	4-1/2	2-1/4	8-5/8	9-3/8
6	1-3/8	1-5/8	3-1/8	2-13/16	5	1-5/8	9	10
	1-3/4	2	3-1/8	3-1/16	5	1-7/8	9-1/4	10-1/4
	2	2-1/4	3-1/8	3-3/16	5	2	9-3/8	10-3/8
	2-1/2	3	3-1/8	3-7/16	5	2-1/4	9-5/8	10-5/8
	3	3-1/2	3-1/8	3-7/16	5	2-1/4	9-5/8	10-5/8
	3-1/2	3-1/2	3-1/8	3-7/16	5	2-1/4	9-5/8	10-5/8
8	1-3/8	1-5/8	3-1/4	2-13/16	5-1/8	1-5/8	9-1/8	10-1/8
	1-3/4	2	3-1/4	3-1/16	5-1/8	1-7/8	9-3/8	10-3/8
	2	2-1/4	3-1/4	3-3/16	5-1/8	2	9-1/2	10-1/2
	2-1/2	3	3-1/4	3-7/16	5-1/8	2-1/4	9-3/4	10-3/4
	3	3-1/2	3-1/4	3-7/16	5-1/8	2-1/4	9-3/4	10-3/4
	3-1/2	3-1/2	3-1/4	3-7/16	5-1/8	2-1/4	9-3/4	10-3/4
	4	4	3-1/4	3-7/16	5-1/8	2-1/4	9-3/4	10-3/4
	4-1/2	4-1/2	3-1/4	3-7/16	5-1/8	2-1/4	9-3/4	10-3/4
	5	5	3-1/4	3-7/16	5-1/8	2-1/4	9-3/4	10-3/4
5-1/2	5-1/2	3-1/4	3-7/16	5-1/8	2-1/4	9-3/4	10-3/4	
10	1-3/4	2	4	3-3/16	6-3/8	1-7/8	11-1/4	12-5/8
	2	2-1/4	4	3-5/16	6-3/8	2	11-3/8	12-3/4
	2-1/2	3	4	3-9/16	6-3/8	2-1/4	11-5/8	13
	3	3-1/2	4	3-9/16	6-3/8	2-1/4	11-5/8	13
	3-1/2	3-1/2	4	3-9/16	6-3/8	2-1/4	11-5/8	13
	4	4	4	3-9/16	6-3/8	2-1/4	11-5/8	13
	4-1/2	4-1/2	4	3-9/16	6-3/8	2-1/4	11-5/8	13
	5	5	4	3-9/16	6-3/8	2-1/4	11-5/8	13
5-1/2	5-1/2	4	3-9/16	6-3/8	2-1/4	11-5/8	13	

**MODEL EU3 (NFPA STD. MPU3)**

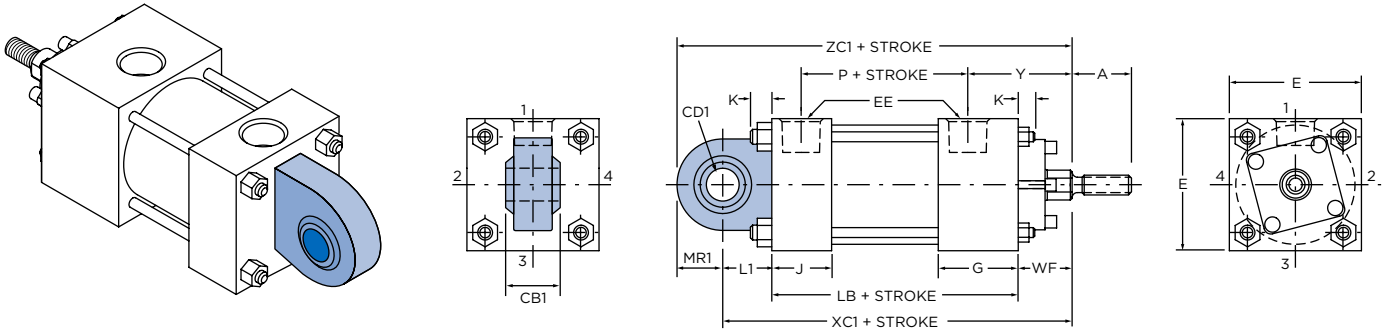

**Table 1** These dimensions are constant regardless of rod diameter or stroke.

BORE DIA.	E	G	J	K	EE	L1	CB1	CD1	MR1	PRESSURE RATING
1-1/2	2	1-1/2	1-1/8	1/4	3/8	3/4	7/16	1/2	7/8	1750 PSI
2	2-1/2	1-1/2	1-1/8	3/8	3/8	3/4	7/16	1/2	7/8	980 PSI
2-1/2	3	1-1/2	1-1/8	3/8	3/8	3/4	7/16	1/2	7/8	630 PSI
3-1/4	3-3/4	1-3/4	1-1/4	7/16	1/2	1-1/4	21/32	3/4	1-1/4	830 PSI
4	4-1/2	1-3/4	1-1/4	7/16	1/2	1-1/4	21/32	3/4	1-1/4	550 PSI
5	5-1/2	1-3/4	1-1/4	1/2	1/2	1-1/4	21/32	3/4	1-1/4	350 PSI
6	6-1/2	2	1-1/2	9/16	3/4	1-1/2	7/8	1	1-1/2	440 PSI

# SPHERICAL EYE MOUNT CYLINDERS

1-1/2" THROUGH 6" DIAMETER

**Table 2** The dimensions given on this table are affected by the piston rod diameter and the stroke.

• = For piston rod dimensions see page 132.

BORE DIA.	ROD MM•	A	P	W	Y	LB	WF	XC1	ZC1
1-1/2	5/8	3/4	2-1/8	5/8	1-15/16	3-5/8	1	5-3/8	6-1/8
	1	1-1/8	2-1/8	1	2-5/16	3-5/8	1-3/8	5-3/4	6-1/2
2	5/8	3/4	2-1/8	5/8	1-15/16	3-5/8	1	5-3/8	6-1/8
	1	1-1/8	2-1/8	1	2-5/16	3-5/8	1-3/8	5-3/4	6-1/2
	1-3/8	1-5/8	2-1/8	1-1/4	2-9/16	3-5/8	1-5/8	6	6-3/4
2-1/2	5/8	3/4	2-1/4	5/8	1-15/16	3-3/4	1	5-1/2	6-1/4
	1	1-1/8	2-1/4	1	2-5/16	3-3/4	1-3/8	5-7/8	5-5/8
	1-3/8	1-5/8	2-1/4	1-1/4	2-9/16	3-3/4	1-5/8	6-1/8	6-7/8
	1-3/4	2	2-1/4	1-1/2	2-13/16	3-3/4	1-7/8	6-3/8	7-1/8
3-1/4	1	1-1/8	2-1/2	3/4	2-1/2	4-1/4	1-3/8	6-7/8	8-1/16
	1-3/8	1-5/8	2-1/2	1	2-3/4	4-1/4	1-5/8	7-1/8	8-5/16
	1-3/4	2	2-1/2	1-1/4	3	4-1/4	1-7/8	7-3/8	8-9/16
	2	2-1/4	2-1/2	1-3/8	3-1/8	4-1/4	2	7-1/2	8-11/16
4	1	1-1/8	2-1/2	3/4	2-1/2	4-1/4	1-3/8	6-7/8	8-1/16
	1-3/8	1-5/8	2-1/2	1	2-3/4	4-1/4	1-5/8	7-1/8	8-5/16
	1-3/4	2	2-1/2	1-1/4	3	4-1/4	1-7/8	7-3/8	8-9/16
	2	2-1/4	2-1/2	1-3/8	3-1/8	4-1/4	2	7-1/2	8-11/16
	2-1/2	3	2-1/2	1-5/8	3-3/8	4-1/4	2-1/4	7-3/4	8-15/16
5	1	1-1/8	2-3/4	3/4	2-1/2	4-1/2	1-3/8	7-1/8	8-5/16
	1-3/8	1-5/8	2-3/4	1	2-3/4	4-1/2	1-5/8	7-3/8	8-9/16
	1-3/4	2	2-3/4	1-1/4	3	4-1/2	1-7/8	7-5/8	8-13/16
	2	2-1/4	2-3/4	1-3/8	3-1/8	4-1/2	2	7-3/4	8-15/16
	2-1/2	3	2-3/4	1-5/8	3-3/8	4-1/2	2-1/4	8	9-3/16
	3	3-1/2	2-3/4	1-5/8	3-3/8	4-1/2	2-1/4	8	9-3/16
	3-1/2	3-1/2	2-3/4	1-5/8	3-3/8	4-1/2	2-1/4	8	9-3/16
6	1-3/8	1-5/8	3-1/8	7/8	2-13/16	5	1-5/8	8-1/8	9-5/8
	1-3/4	2	3-1/8	1-1/8	3-1/16	5	1-7/8	8-3/8	9-7/8
	2	2-1/4	3-1/8	1-1/4	3-3/16	5	2	8-1/2	10
	2-1/2	3	3-1/8	1-1/2	3-7/16	5	2-1/4	8-3/4	10-1/4
	3	3-1/2	3-1/8	-	3-3/16	5	-	8-3/4	10-1/4
	3-1/2	3-1/2	3-1/8	-	3-7/16	5	-	8-3/4	10-1/4
	4	4	3-1/8	-	-	5	-	8-3/4	10-1/4

**MODEL F (NFPA STD. MT4)** ▲

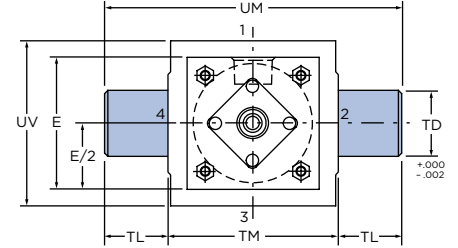
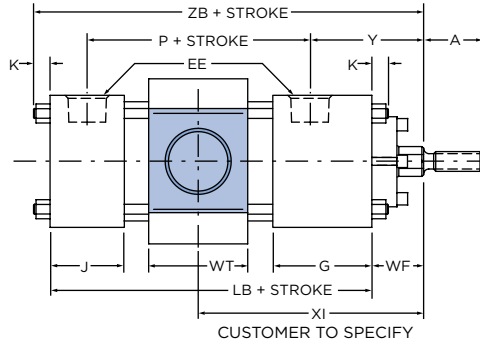
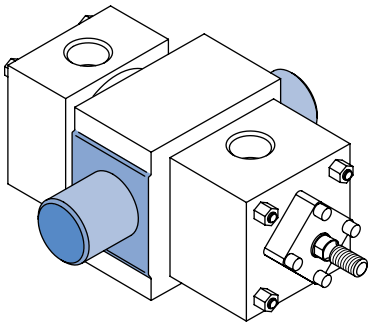

**MODEL FB (NFPA STD. MT2)** ▲

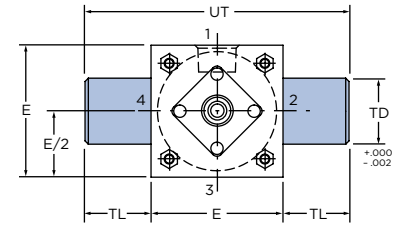
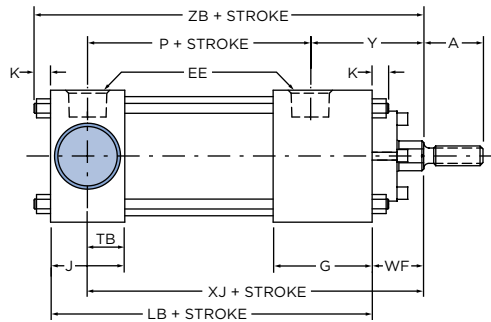
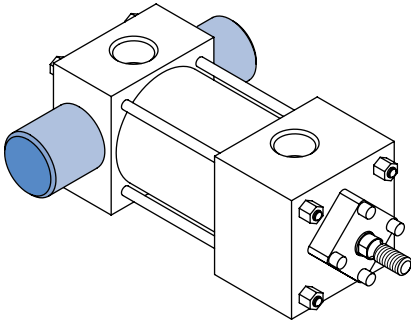

**MODEL FR (NFPA STD. MT1)** ▲

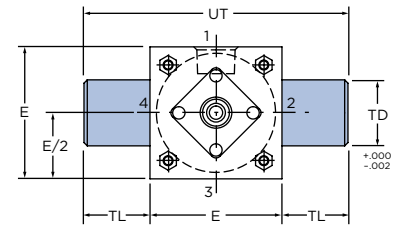
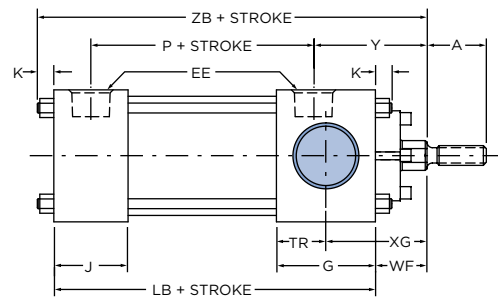
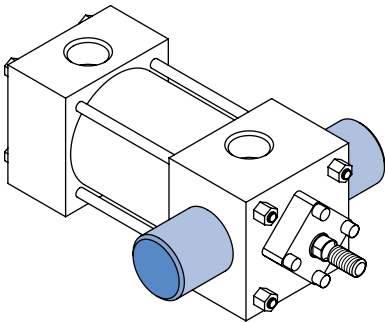

▲ = See Table A on page 127 for bore and rod combinations using head plates with threaded bronze glands.

# TRUNNION MOUNT CYLINDERS

1-1/2" THROUGH 6" DIAMETER

**Table 1** These dimensions are constant regardless of rod diameter or stroke.

Double rod end models are designated by letter "X" preceding the model identification. See page 128.

BORE DIA.	E	G	J	K	EE	TB	TD	TL	TM	TR	UM	UT	UV	WT
1-1/2	2	1-1/2	1-1/8	1/4	3/8	9/16	1	1	2-1/2	3/4	4-1/2	4	2-1/2	1-1/2
2	2-1/2	1-1/2	1-1/8	3/8	3/8	9/16	1	1	3	3/4	5	4-1/2	3	1-1/2
2-1/2	3	1-1/2	1-1/8	3/8	3/8	9/16	1	1	3-1/2	3/4	5-1/2	5	3-1/2	1-1/2
3-1/4	3-3/4	1-3/4	1-1/4	7/16	1/2	5/8	1	1	4-1/2	7/8	6-1/2	5-3/4	4-1/2	2
4	4-1/2	1-3/4	1-1/4	7/16	1/2	5/8	1	1	5-1/4	7/8	7-1/4	6-1/2	5	2
5	5-1/2	1-3/4	1-1/4	1/2	1/2	5/8	1	1	6-1/4	7/8	8-1/4	7-1/2	6	2
6	6-1/2	2	1-1/2	9/16	3/4	3/4	1-3/8	1-3/8	7-5/8	1	10-3/8	9-1/4	7	2-1/2

**Table 2** The dimensions given on this table are affected by the piston rod diameter and the stroke.

• = For piston rod dimensions see page 132.

BORE DIA.	ROD MM•	A	P	Y	LB	WF	XG	XI (MIN)	XJ	ZB
1-1/2	5/8	3/4	2-1/8	1-15/16	3-5/8	1	1-3/4	3-1/4	4-1/16	4-7/8
	1	1-1/8	2-1/8	2-5/16	3-5/8	1-3/8	2-1/8	3-5/8	4-7/16	5-1/4
2	5/8	3/4	2-1/8	1-15/16	3-5/8	1	1-3/4	3-1/4	4-1/16	5
	1	1-1/8	2-1/8	2-5/16	3-5/8	1-3/8	2-1/8	3-5/8	4-7/16	5-3/8
	1-3/8	1-5/8	2-1/8	2-9/16	3-5/8	1-5/8	2-3/8	3-7/8	4-11/16	5-11/16
2-1/2	5/8	3/4	2-1/4	1-15/16	3-3/4	1	1-3/4	3-1/4	4-3/16	5-1/16
	1	1-1/8	2-1/4	2-5/16	3-3/4	1-3/8	2-1/8	3-5/8	4-9/16	5-7/16
	1-3/8	1-5/8	2-1/4	2-9/16	3-3/4	1-5/8	2-3/8	3-7/8	4-13/16	5-11/16
	1-3/4	2	2-1/4	2-13/16	3-3/4	1-7/8	2-5/8	4-1/8	5-1/16	5-15/16
3-1/4	1	1-1/8	2-1/2	2-1/2	4-1/4	1-3/8	2-1/4	4-1/8	5	6-1/16
	1-3/8	1-5/8	2-1/2	2-3/4	4-1/4	1-5/8	2-1/2	4-3/8	5-1/4	6-5/16
	1-3/4	2	2-1/2	3	4-1/4	1-7/8	2-3/4	4-5/8	5-1/2	6-9/16
	2	2-1/4	2-1/2	3-1/8	4-1/4	2	2-7/8	4-3/4	5-5/8	6-11/16
4	1	1-1/8	2-1/2	2-1/2	4-1/4	1-3/8	2-1/4	4-1/8	5	6-1/16
	1-3/8	1-5/8	2-1/2	2-3/4	4-1/4	1-5/8	2-1/2	4-3/8	5-1/4	6-5/16
	1-3/4	2	2-1/2	3	4-1/4	1-7/8	2-3/4	4-5/8	5-1/2	6-9/16
	2	2-1/4	2-1/2	3-1/8	4-1/4	2	2-7/8	4-3/4	5-5/8	6-11/16
	2-1/2	3	2-1/2	3-3/8	4-1/4	2-1/4	3-1/8	5	5-7/8	6-15/16
5	1	1-1/8	2-3/4	2-1/2	4-1/2	1-3/8	2-1/4	4-1/8	5-1/4	6-3/8
	1-3/8	1-5/8	2-3/4	2-3/4	4-1/2	1-5/8	2-1/2	4-3/8	5-1/2	6-5/8
	1-3/4	2	2-3/4	3	4-1/2	1-7/8	2-3/4	4-5/8	5-3/4	6-7/8
	2	2-1/4	2-3/4	3-1/8	4-1/2	2	2-7/8	4-3/4	5-7/8	7
	2-1/2	3	2-3/4	3-3/8	4-1/2	2-1/4	3-1/8	5	6-1/8	7-1/4
	3	3-1/2	2-3/4	3-3/8	4-1/2	2-1/4	3-1/8	5	6-1/8	7-1/4
	3-1/2	3-1/2	2-3/4	3-3/8	4-1/2	2-1/4	3-1/8	5	6-1/8	7-1/4
6	1-3/8	1-5/8	3-1/8	2-13/16	5	1-5/8	2-5/8	4-7/8	5-7/8	7-3/16
	1-3/4	2	3-1/8	3-1/16	5	1-7/8	2-7/8	5-1/8	6-1/8	7-7/16
	2	2-1/4	3-1/8	3-3/16	5	2	3	5-1/4	6-1/4	7-9/16
	2-1/2	3	3-1/8	3-7/16	5	2-1/4	3-1/4	5-1/2	6-1/2	7-13/16
	3	3-1/2	3-1/8	3-7/16	5	2-1/4	3-1/4	5-1/2	6-1/2	7-13/16
	3-1/2	3-1/2	3-1/8	3-7/16	5	2-1/4	3-1/4	5-1/2	6-1/2	7-13/16
	4	4	3-1/8	3-7/16	5	2-1/4	3-1/4	5-1/2	6-1/2	7-13/16

**MODEL F (NFPA STD. MT4) 8" THROUGH 14" DIAMETER**

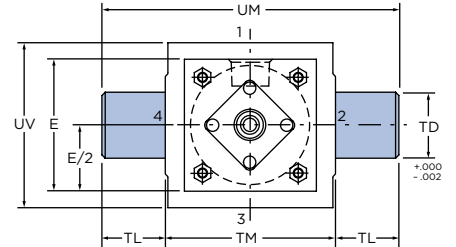
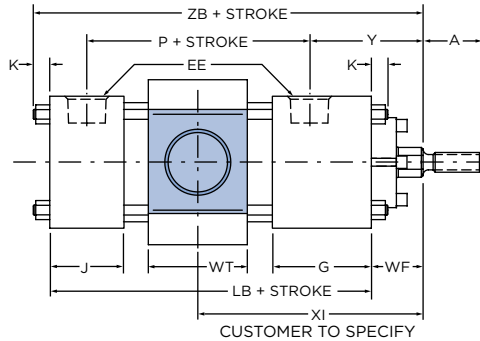
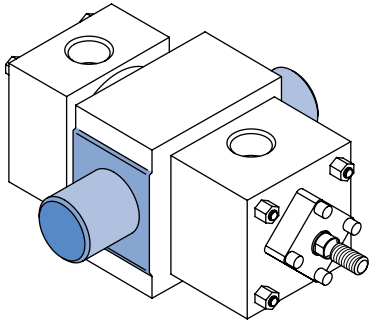

**MODEL FB (NFPA STD. MT2) 8" THROUGH 20" DIAMETER**

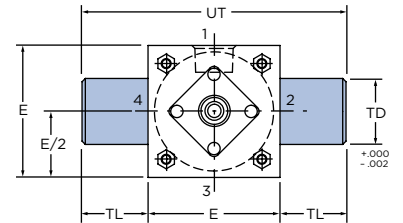
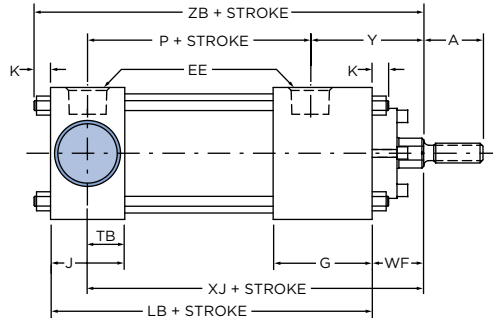
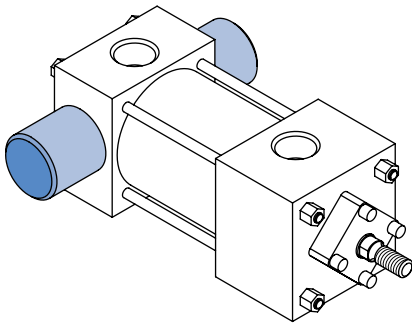

**MODEL FR (NFPA STD. MT1) 8" THROUGH 20" DIAMETER**

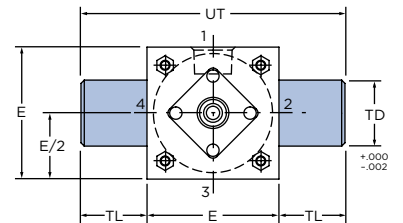
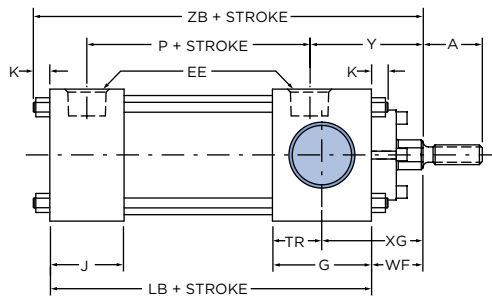
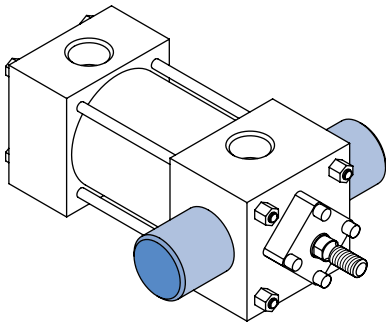

**Table 1** These dimensions are constant regardless of rod diameter or stroke.

Double rod end models are designated by letter "X" preceding the model identification. See page 128.

BORE DIA.	E	G	J	K	EE	TB	TD	TL	TM	TR	UM	UT	UV	WT
8	8-1/2	2	1-1/2	5/8	3/4	3/4	1-3/8	1-3/8	9-3/4	1	12-1/2	11-1/4	9-1/2	2-1/2
10	10-5/8	2-1/4	2	3/4	1	1	1-3/4	1-3/4	12	1-1/8	15-1/2	14-1/8	11-3/4	3
12	12-3/4	2-1/4	2	3/4	1	1	1-3/4	1-3/4	14	1-1/8	17-1/2	16-1/4	13-3/4	3
14	14-3/4	2-3/4	2-1/4	7/8	1-1/4	1-1/8	2	2	16-1/4	1-3/8	20-1/4	18-3/4	16	3-1/2
16	17-1/2	3	3	1	1-1/2	1-1/2	2-3/4	2-3/4	-	1-1/2	-	23	-	-
18	19-1/2	3-7/16	3-7/16	1-1/8	1-1/2	1-11/16	3	3	-	1-11/16	-	25-1/2	-	-
20	21-3/4	3-15/16	3-15/16	1-1/4	2	1-15/16	3-1/2	3-1/2	-	1-15/16	-	28-3/4	-	-



# TRUNNION MOUNT CYLINDERS

8" THROUGH 20" DIAMETER

**Table 2** The dimensions given on this table are affected by the piston rod diameter and the stroke.

• = For piston rod dimensions see page 132.

BORE DIA.	ROD MM•	A	P	Y	LB	WF	XG	XI (MIN)	XJ	ZB
8	1-3/8	1-5/8	3-1/4	2-13/16	5-1/8	1-5/8	2-5/8	4-7/8	6	7-3/8
	1-3/4	2	3-1/4	3-1/16	5-1/8	1-7/8	2-7/8	5-1/8	6-1/4	7-5/8
	2	2-1/4	3-1/4	3-3/16	5-1/8	2	3	5-1/4	6-3/8	7-3/4
	2-1/2	3	3-1/4	3-7/16	5-1/8	2-1/4	3-1/4	5-1/2	6-5/8	8
	3	3-1/2	3-1/4	3-7/16	5-1/8	2-1/4	3-1/4	5-1/2	6-5/8	8
	3-1/2	3-1/2	3-1/4	3-7/16	5-1/8	2-1/4	3-1/4	5-1/2	6-5/8	8
	4	4	3-1/4	3-7/16	5-1/8	2-1/4	3-1/4	5-1/2	6-5/8	8
	4-1/2	4-1/2	3-1/4	3-7/16	5-1/8	2-1/4	3-1/4	5-1/2	6-5/8	8
10	5	5	3-1/4	3-7/16	5-1/8	2-1/4	3-1/4	5-1/2	6-5/8	8
	5-1/2	5-1/2	3-1/4	3-7/16	5-1/8	2-1/4	3-1/4	5-1/2	6-5/8	8
	1-3/4	2	4	3-3/16	6-3/8	1-7/8	3	5-5/8	7-1/4	9
	2	2-1/4	4	3-5/16	6-3/8	2	3-1/8	5-3/4	7-3/8	9-1/8
	2-1/2	3	4	3-9/16	6-3/8	2-1/4	3-3/8	6	7-5/8	9-3/8
	3	3-1/2	4	3-9/16	6-3/8	2-1/4	3-3/8	6	7-5/8	9-3/8
	3-1/2	3-1/2	4	3-9/16	6-3/8	2-1/4	3-3/8	6	7-5/8	9-3/8
	4	4	4	3-9/16	6-3/8	2-1/4	3-3/8	6	7-5/8	9-3/8
12	4-1/2	4-1/2	4	3-9/16	6-3/8	2-1/4	3-3/8	6	7-5/8	9-3/8
	5	5	4	3-9/16	6-3/8	2-1/4	3-3/8	6	7-5/8	9-3/8
	5-1/2	5-1/2	4	3-9/16	6-3/8	2-1/4	3-3/8	6	7-5/8	9-3/8
	2	2-1/4	4-1/2	3-5/16	6-7/8	2	3-1/8	5-3/4	7-7/8	9-5/8
	2-1/2	3	4-1/2	3-9/16	6-7/8	2-1/4	3-3/8	6	8-1/8	9-7/8
	3	3-1/2	4-1/2	3-9/16	6-7/8	2-1/4	3-3/8	6	8-1/8	9-7/8
	3-1/2	3-1/2	4-1/2	3-9/16	6-7/8	2-1/4	3-3/8	6	8-1/8	9-7/8
	4	4	4-1/2	3-9/16	6-7/8	2-1/4	3-3/8	6	8-1/8	9-7/8
14	4-1/2	4-1/2	4-1/2	3-9/16	6-7/8	2-1/4	3-3/8	6	8-1/8	9-7/8
	5	5	4-1/2	3-9/16	6-7/8	2-1/4	3-3/8	6	8-1/8	9-7/8
	5-1/2	5-1/2	4-1/2	3-9/16	6-7/8	2-1/4	3-3/8	6	8-1/8	9-7/8
	2-1/2	3	5-1/2	3-13/16	8-1/8	2-1/4	3-5/8	6	9-1/4	11-1/4
	3	3-1/2	5-1/2	3-13/16	8-1/8	2-1/4	3-5/8	6	9-1/4	11-1/4
	3-1/2	3-1/2	5-1/2	3-13/16	8-1/8	2-1/4	3-5/8	6	9-1/4	11-1/4
	4	4	5-1/2	3-13/16	8-1/8	2-1/4	3-5/8	6	9-1/4	11-1/4
16	4-1/2	4-1/2	5-1/2	3-13/16	8-1/8	2-1/4	3-5/8	6	9-1/4	11-1/4
	5	5	5-1/2	3-13/16	8-1/8	2-1/4	3-5/8	6	9-1/4	11-1/4
	5-1/2	5-1/2	5-1/2	3-13/16	8-1/8	2-1/4	3-5/8	6	9-1/4	11-1/4
	2-1/2	3	5-7/8	3-15/16	9-1/4	2-1/4	3-3/4	-	10	12-1/2
	3	3-1/2	5-7/8	3-15/16	9-1/4	2-1/4	3-3/4	-	10	12-1/2
	3-1/2	3-1/2	5-7/8	3-15/16	9-1/4	2-1/4	3-3/4	-	10	12-1/2
	4	4	5-7/8	3-15/16	9-1/4	2-1/4	3-3/4	-	10	12-1/2
18	4-1/2	4-1/2	5-7/8	3-15/16	9-1/4	2-1/4	3-3/4	-	10	12-1/2
	5	5	5-7/8	3-15/16	9-1/4	2-1/4	3-3/4	-	10	12-1/2
	5-1/2	5-1/2	5-7/8	3-15/16	9-1/4	2-1/4	3-3/4	-	10	12-1/2
	3-1/2	3-1/2	6	4-3/8	10-1/4	2-1/4	4	-	10-3/4	13-5/8
	4	4	6	4-3/8	10-1/4	2-1/4	4	-	10-3/4	13-5/8
20	4-1/2	4-1/2	6	4-3/8	10-1/4	2-1/4	4	-	10-3/4	13-5/8
	5	5	6	4-3/8	10-1/4	2-1/4	4	-	10-3/4	13-5/8
	5-1/2	5-1/2	6	4-3/8	10-1/4	2-1/4	4	-	10-3/4	13-5/8
	4	4	7-1/8	4-9/16	11-3/4	2-1/4	4-1/4	-	12	15-1/4
	4-1/2	4-1/2	7-1/8	4-9/16	11-3/4	2-1/4	4-1/4	-	12	15-1/4

**MODEL T (NFPA STD. MX1)**

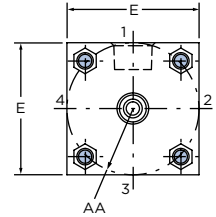
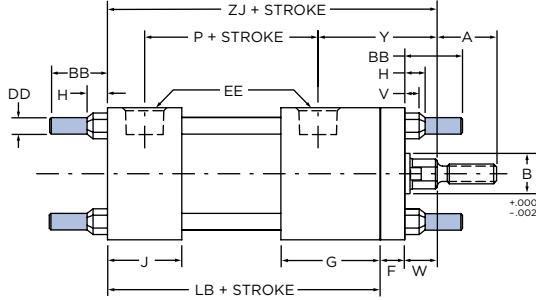
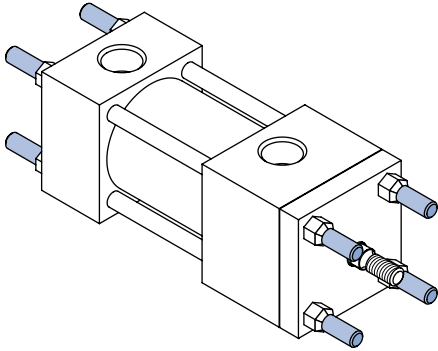

**MODEL TB (NFPA STD. MX2) ▲**

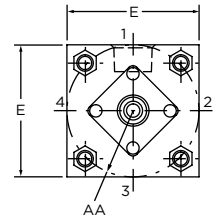
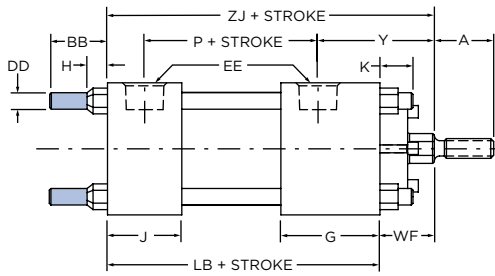
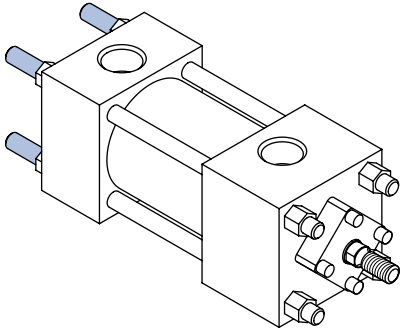

**MODEL TR (NFPA STD. MX3)**

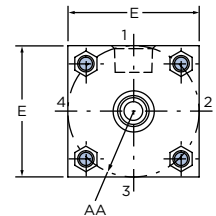
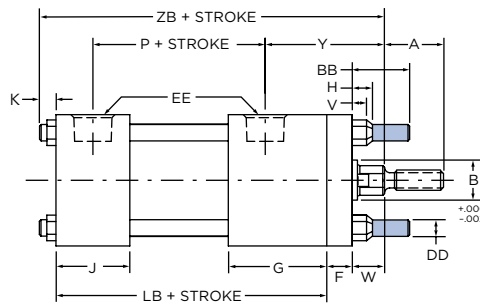
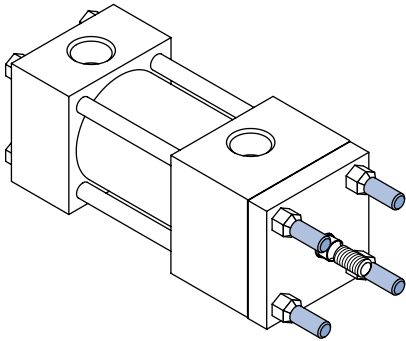

▲ = See Table A on page 127 for bore and rod combinations using head plates with threaded bronze glands.

# TIE-ROD MOUNT CYLINDERS

1-1/2" THROUGH 6" DIAMETER

**Table 1** These dimensions are constant regardless of rod diameter or stroke.

Double rod end models are designated by letter "X" preceding the model identification. See page 128.

BORE DIA.	E	F	G	H	J	K	AA	BB	DD	EE
1-1/2	2	3/8	1-1/2	7/32	1-1/8	1/4	2.02	7/8	1/4-28	3/8
2	2-1/2	3/8	1-1/2	9/32	1-1/8	7/16	2.60	1-3/16	5/16-24	3/8
2-1/2	3	3/8	1-1/2	9/32	1-1/8	5/16	3.10	1-1/8	5/16-24	3/8
3-1/4	3-3/4	5/8	1-3/4	3/8	1-1/4	7/16	4.00	1-3/8	3/8-24	1/2
4	4-1/2	5/8	1-3/4	3/8	1-1/4	7/16	4.75	1-3/8	3/8-24	1/2
5	5-1/2	5/8	1-3/4	7/16	1-1/4	1/2	5.80	1-3/4	1/2-20	1/2
6	6-1/2	3/4	2	1/2	1-1/2	9/16	6.90	1-3/4	1/2-20	3/4

**Table 2** The dimensions given on this table are affected by the piston rod diameter and the stroke.

• = For piston rod dimensions see page 132.

BORE DIA.	ROD MM•	A	B	P	V	W	Y	LB	WF	ZB	ZJ
1-1/2	5/8	3/4	1-1/8	2-1/8	1/4	5/8	1-15/16	3-5/8	1	4-7/8	4-5/8
	1	1-1/8	1-1/2	2-1/8	1/2	1	2-5/16	3-5/8	1-3/8	5-1/4	5
2	5/8	3/4	1-1/8	2-1/8	1/4	5/8	1-15/16	3-5/8	1	5	4-5/8
	1	1-1/8	1-1/2	2-1/8	1/2	1	2-5/16	3-5/8	1-3/8	5-3/8	5
	1-3/8	1-5/8	2	2-1/8	5/8	1-1/4	2-9/16	3-5/8	1-5/8	5-11/16	5-1/4
2-1/2	5/8	3/4	1-1/8	2-1/4	1/4	5/8	1-15/16	3-3/4	1	5-1/16	4-3/4
	1	1-1/8	1-1/2	2-1/4	1/2	1	2-5/16	3-3/4	1-3/8	5-7/16	5-1/8
	1-3/8	1-5/8	2	2-1/4	5/8	1-1/4	2-9/16	3-3/4	1-5/8	5-11/16	5-3/8
	1-3/4	2	2-3/8	2-1/4	3/4	1-1/2	2-13/16	3-3/4	1-7/8	5-15/16	5-5/8
3-1/4	1	1-1/8	1-1/2	2-1/2	1/4	3/4	2-1/2	4-1/4	1-3/8	6-1/16	5-5/8
	1-3/8	1-5/8	2	2-1/2	3/8	1	2-3/4	4-1/4	1-5/8	6-5/16	5-7/8
	1-3/4	2	2-3/8	2-1/2	1/2	1-1/4	3	4-1/4	1-7/8	6-9/16	6-1/8
	2	2-1/4	2-5/8	2-1/2	1/2	1-3/8	3-1/8	4-1/4	2	6-11/16	6-1/4
4	1	1-1/8	1-1/2	2-1/2	1/4	3/4	2-1/2	4-1/4	1-3/8	6-1/16	5-5/8
	1-3/8	1-5/8	2	2-1/2	3/8	1	2-3/4	4-1/4	1-5/8	6-5/16	5-7/8
	1-3/4	2	2-3/8	2-1/2	1/2	1-1/4	3	4-1/4	1-7/8	6-9/16	6-1/8
	2	2-1/4	2-5/8	2-1/2	1/2	1-3/8	3-1/8	4-1/4	2	6-11/16	6-1/4
	2-1/2	3	3-1/8	2-1/2	5/8	1-5/8	3-3/8	4-1/4	2-1/4	6-15/16	6-1/2
5	1	1-1/8	1-1/2	2-3/4	1/4	3/4	2-1/2	4-1/2	1-3/8	6-3/8	5-7/8
	1-3/8	1-5/8	2	2-3/4	3/8	1	2-3/4	4-1/2	1-5/8	6-5/8	6-1/8
	1-3/4	2	2-3/8	2-3/4	1/2	1-1/4	3	4-1/2	1-7/8	6-7/8	6-3/8
	2	2-1/4	2-5/8	2-3/4	1/2	1-3/8	3-1/8	4-1/2	2	7	6-1/2
	2-1/2	3	3-1/8	2-3/4	5/8	1-5/8	3-3/8	4-1/2	2-1/4	7-1/4	6-3/4
	3	3-1/2	3-3/4	2-3/4	5/8	1-5/8	3-3/8	4-1/2	2-1/4	7-1/4	6-3/4
	3-1/2	3-1/2	4-1/4	2-3/4	5/8	1-5/8	3-3/8	4-1/2	2-1/4	7-1/4	6-3/4
6	1-3/8	1-5/8	2	3-1/8	1/4	7/8	2-13/16	5	1-5/8	7-3/16	6-5/8
	1-3/4	2	2-3/8	3-1/8	3/8	1-1/8	3-1/16	5	1-7/8	7-7/16	6-7/8
	2	2-1/4	2-5/8	3-1/8	3/8	1-1/4	3-3/16	5	2	7-9/16	7
	2-1/2	3	3-1/8	3-1/8	1/2	1-1/2	3-7/16	5	2-1/4	7-13/16	7-1/4
	3	3-1/2	3-3/4	3-1/8	1/2	1-1/2	3-7/16	5	2-1/4	7-13/16	7-1/4
	3-1/2	3-1/2	4-1/4	3-1/8	1/2	1-1/2	3-7/16	5	2-1/4	7-13/16	7-1/4
	4	4	4-3/4	3-1/8	1/2	1-1/2	3-7/16	5	2-1/4	7-13/16	7-1/4

**MODEL T (NFPA STD. MX1)**

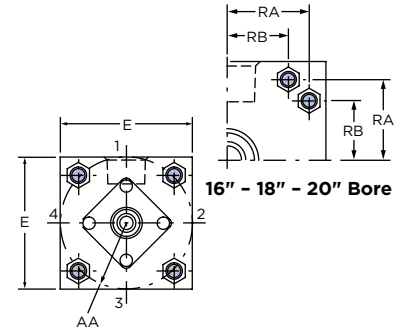
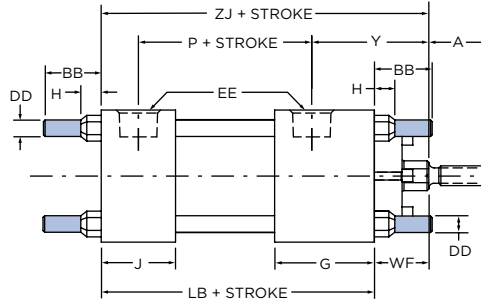
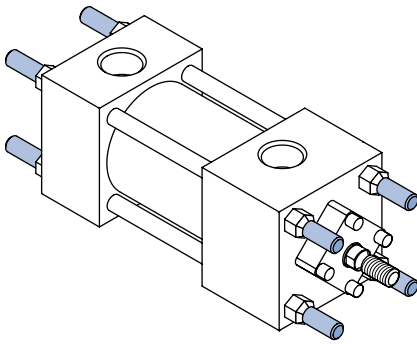

**MODEL TB (NFPA STD. MX2)**

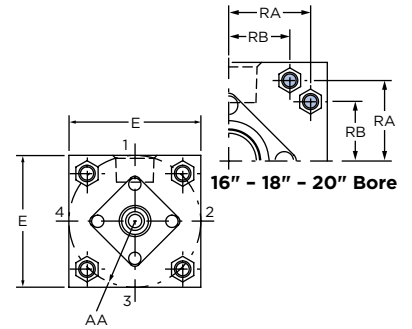
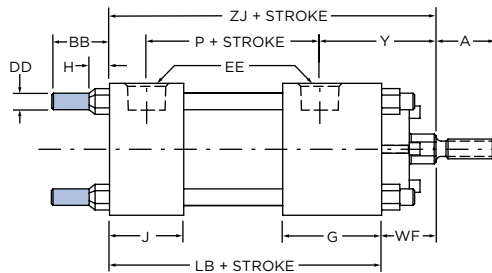
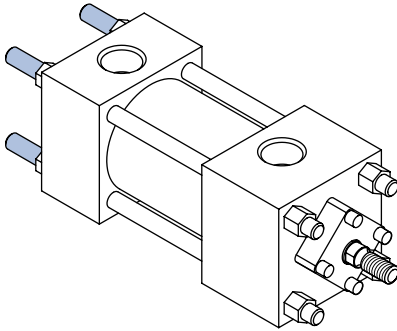

**MODEL TR (NFPA STD. MX3)**

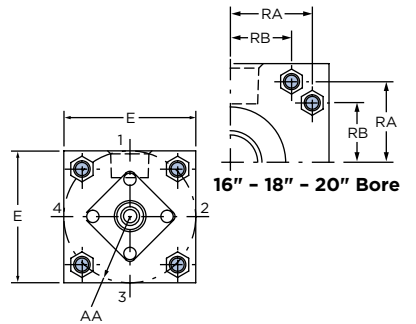
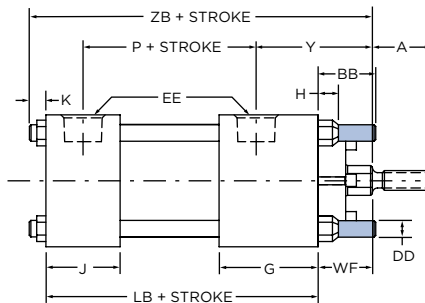
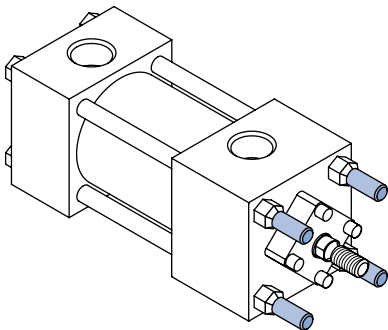

**Table 1** These dimensions are constant regardless of rod diameter or stroke.

Double rod end models are designated by letter "X" preceding the model identification. See page 128.

BORE DIA.	E	G	H	J	K	AA	BB	DD	EE	RA	RB
8	8-1/2	2	9/16	1-1/2	5/8	9.10	2-1/4	5/8-18	3/4	-	-
10	10-5/8	2-1/4	5/8	2	3/4	11.31	2-5/8	3/4-16	1	-	-
12	12-3/4	2-1/4	5/8	2	3/4	13.30	2-11/16	3/4-16	1	-	-
14	14-3/4	2-3/4	3/4	2-1/4	7/8	15.40	3-3/16	7/8-14	1-1/4	-	-
16	17-1/2	3	7/8	3	1	18.25	3-5/8	1-14	1-1/2	7.48	5.23
18	19-1/2	3-7/16	1	3-7/16	1-1/8	20.50	4-1/8	1-1/8-12	1-1/2	8.40	5.88
20	21-3/4	3-15/16	1-1/8	3-15/16	1-1/4	22.62	4-1/2	1-1/4-12	2	9.27	6.49

# TIE-ROD MOUNT CYLINDERS

8" THROUGH 20" DIAMETER

**Table 2** The dimensions given on this table are affected by the piston rod diameter and the stroke.

• = For piston rod dimensions see page 132.

BORE DIA.	ROD MM•	A	P	Y	LB	WF	ZB	ZJ
8	1-3/8	1-5/8	3-1/4	2-13/16	5-1/8	1-5/8	7-3/8	6-3/4
	1-3/4	2	3-1/4	3-1/16	5-1/8	1-7/8	7-5/8	7
	2	2-1/4	3-1/4	3-3/16	5-1/8	2	7-3/4	7-1/8
	2-1/2	3	3-1/4	3-7/16	5-1/8	2-1/4	8	7-3/8
	3	3-1/2	3-1/4	3-7/16	5-1/8	2-1/4	8	7-3/8
	3-1/2	3-1/2	3-1/4	3-7/16	5-1/8	2-1/4	8	7-3/8
	4	4	3-1/4	3-7/16	5-1/8	2-1/4	8	7-3/8
	4-1/2	4-1/2	3-1/4	3-7/16	5-1/8	2-1/4	8	7-3/8
	5	5	3-1/4	3-7/16	5-1/8	2-1/4	8	7-3/8
	5-1/2	5-1/2	3-1/4	3-7/16	5-1/8	2-1/4	8	7-3/8
10	1-3/4	2	4	3-3/16	6-3/8	1-7/8	9	8-1/4
	2	2-1/4	4	3-5/16	6-3/8	2	9-1/8	8-3/8
	2-1/2	3	4	3-9/16	6-3/8	2-1/4	9-3/8	8-5/8
	3	3-1/2	4	3-9/16	6-3/8	2-1/4	9-3/8	8-5/8
	3-1/2	3-1/2	4	3-9/16	6-3/8	2-1/4	9-3/8	8-5/8
	4	4	4	3-9/16	6-3/8	2-1/4	9-3/8	8-5/8
	4-1/2	4-1/2	4	3-9/16	6-3/8	2-1/4	9-3/8	8-5/8
	5	5	4	3-9/16	6-3/8	2-1/4	9-3/8	8-5/8
12	2	2-1/4	4-1/2	3-5/16	6-7/8	2	9-5/8	8-7/8
	2-1/2	3	4-1/2	3-9/16	6-7/8	2-1/4	9-7/8	9-1/8
	3	3-1/2	4-1/2	3-9/16	6-7/8	2-1/4	9-7/8	9-1/8
	3-1/2	3-1/2	4-1/2	3-9/16	6-7/8	2-1/4	9-7/8	9-1/8
	4	4	4-1/2	3-9/16	6-7/8	2-1/4	9-7/8	9-1/8
	4-1/2	4-1/2	4-1/2	3-9/16	6-7/8	2-1/4	9-7/8	9-1/8
	5	5	4-1/2	3-9/16	6-7/8	2-1/4	9-7/8	9-1/8
	5-1/2	5-1/2	4-1/2	3-9/16	6-7/8	2-1/4	9-7/8	9-1/8
14	2-1/2	3	5-1/2	3-13/16	8-1/8	2-1/4	11-1/4	10-3/8
	3	3-1/2	5-1/2	3-13/16	8-1/8	2-1/4	11-1/4	10-3/8
	3-1/2	3-1/2	5-1/2	3-13/16	8-1/8	2-1/4	11-1/4	10-3/8
	4	4	5-1/2	3-13/16	8-1/8	2-1/4	11-1/4	10-3/8
	4-1/2	4-1/2	5-1/2	3-13/16	8-1/8	2-1/4	11-1/4	10-3/8
	5	5	5-1/2	3-13/16	8-1/8	2-1/4	11-1/4	10-3/8
	5-1/2	5-1/2	5-1/2	3-13/16	8-1/8	2-1/4	11-1/4	10-3/8
16	2-1/2	3	5-7/8	3-15/16	9-1/4	2-1/4	12-1/2	11-1/2
	3	3-1/2	5-7/8	3-15/16	9-1/4	2-1/4	12-1/2	11-1/2
	3-1/2	3-1/2	5-7/8	3-15/16	9-1/4	2-1/4	12-1/2	11-1/2
	4	4	5-7/8	3-15/16	9-1/4	2-1/4	12-1/2	11-1/2
	4-1/2	4-1/2	5-7/8	3-15/16	9-1/4	2-1/4	12-1/2	11-1/2
	5	5	5-7/8	3-15/16	9-1/4	2-1/4	12-1/2	11-1/2
	5-1/2	5-1/2	5-7/8	3-15/16	9-1/4	2-1/4	12-1/2	11-1/2
18	3-1/2	3-1/2	6	4-3/8	10-1/4	2-1/4	13-5/8	12-1/2
	4	4	6	4-3/8	10-1/4	2-1/4	13-5/8	12-1/2
	4-1/2	4-1/2	6	4-3/8	10-1/4	2-1/4	13-5/8	12-1/2
	5	5	6	4-3/8	10-1/4	2-1/4	13-5/8	12-1/2
	5-1/2	5-1/2	6	4-3/8	10-1/4	2-1/4	13-5/8	12-1/2
20	4	4	7-1/8	4-9/16	11-3/4	2-1/4	15-1/4	14
	4-1/2	4-1/2	7-1/8	4-9/16	11-3/4	2-1/4	15-1/4	14
	5	5	7-1/8	4-9/16	11-3/4	2-1/4	15-1/4	14
	5-1/2	5-1/2	7-1/8	4-9/16	11-3/4	2-1/4	15-1/4	14

**MODEL UE (NFPA STD. NONE)** ▲

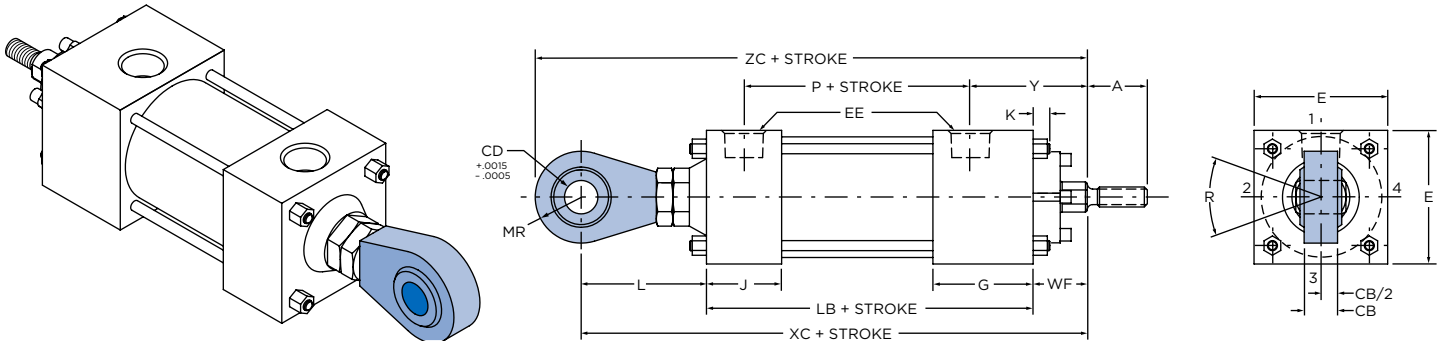

**MODEL UUE (NFPA STD. NONE)** ▲

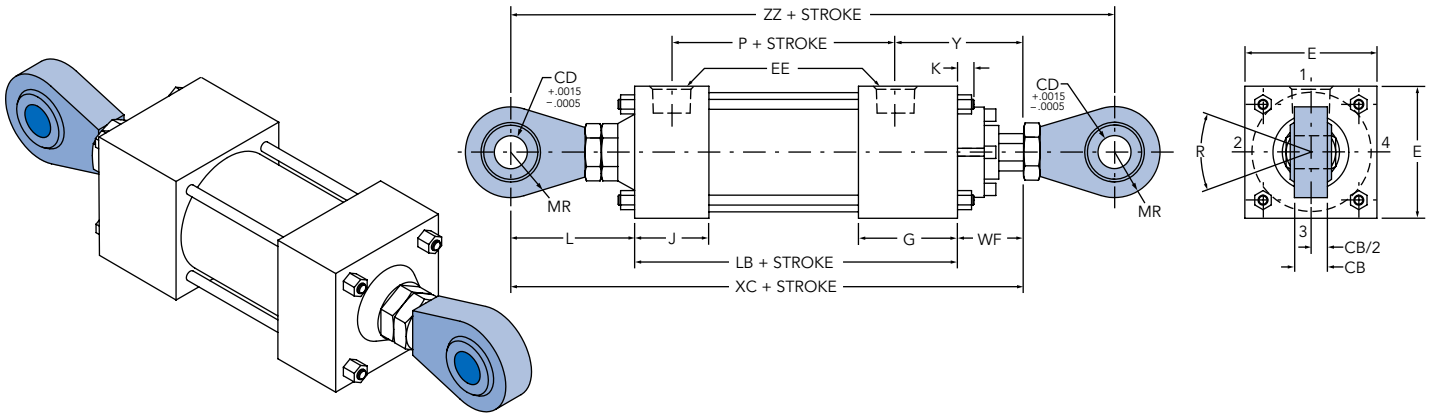

▲ = See Table A on page 127 for bore and rod combinations using head plates with threaded bronze glands.

**Table 1** These dimensions are constant regardless of rod diameter or stroke.

BORE DIA.	E	F	G	K	L	R	CB	CD	EE	MR
1-1/2	2	3/8	1-1/2	1/4	1-7/8	12°	5/8	1/2	3/8	11/16
2	2-1/2	3/8	1-1/2	3/8	1-7/8	12°	5/8	1/2	3/8	11/16
2-1/2	3	3/8	1-1/2	5/16	1-7/8	12°	5/8	1/2	3/8	11/16
3-1/4	3-3/4	5/8	1-3/4	7/16	2-7/8	13-1/2°	7/8	3/4	1/2	7/8
4	4-1/2	5/8	1-3/4	7/16	2-7/8	13-1/2°	7/8	3/4	1/2	7/8
5	5-1/2	5/8	1-3/4	1/2	2-7/8	13-1/2°	7/8	3/4	1/2	7/8
6	6-1/2	3/4	2	9/16	4-1/8	14°	1-3/8	1	3/4	1-3/8

# SPHERICAL EYE PIN MOUNT CYLINDERS

1-1/2" THROUGH 6" DIAMETER

**Table 2** The dimensions given on this table are affected by the piston rod diameter and the stroke.

• = For piston rod dimensions see page 132.

BORE DIA.	ROD MM•	A	P	Y	LB	W	WF	XC	ZC	ZZ
1-1/2	5/8	3/4	2-1/8	1-15/16	3-5/8	5/8	1	6-1/2	7-3/16	7-11/16
	1	1-1/8	2-1/8	2-5/16	3-5/8	1	1-3/8	6-7/8	7-9/16	8-1/16
2	5/8	3/4	2-1/8	1-15/16	3-5/8	-	1	6-1/2	7-3/16	7-11/16
	1	1-1/8	2-1/8	2-5/16	3-5/8	1	1-3/8	6-7/8	7-9/16	8-1/16
	1-3/8	1-5/8	2-1/8	2-9/16	3-5/8	1-1/4	1-5/8	7-1/8	7-13/16	8-5/16
2-1/2	5/8	3/4	2-1/4	1-15/16	3-3/4	-	1	6-5/8	7-5/16	7-13/16
	1	1-1/8	2-1/4	2-5/16	3-3/4	-	1-3/8	7	7-11/16	8-3/16
	1-3/8	1-5/8	2-1/4	2-9/16	3-3/4	-	1-5/8	7-1/4	7-15/16	8-7/16
	1-3/4	2	2-1/4	2-13/16	3-3/4	1-1/2	1-7/8	7-1/2	8-3/16	8-11/16
3-1/4	1	1-1/8	2-1/2	2-1/2	4-1/4	-	1-3/8	8-1/2	9-3/8	10-1/16
	1-3/8	1-5/8	2-1/2	2-3/4	4-1/4	-	1-5/8	8-3/4	9-5/8	10-5/16
	1-3/4	2	2-1/2	3	4-1/4	-	1-7/8	9	9-7/8	10-9/16
	2	2-1/4	2-1/2	3-1/8	4-1/4	1-3/8	2	9-1/8	10	10-11/16
4	1	1-1/8	2-1/2	2-1/2	4-1/4	-	1-3/8	8-1/2	9-3/8	10-1/16
	1-3/8	1-5/8	2-1/2	2-3/4	4-1/4	-	1-5/8	8-3/4	9-5/8	10-5/16
	1-3/4	2	2-1/2	3	4-1/4	-	1-7/8	9	9-7/8	10-9/16
	2	2-1/4	2-1/2	3-1/8	4-1/4	-	2	9-1/8	10	10-11/16
	2-1/2	3	2-1/2	3-3/8	4-1/4	1-5/8	2-1/4	9-3/8	10-1/4	10-15/16
5	1	1-1/8	2-3/4	2-1/2	4-1/2	-	1-3/8	8-3/4	9-5/8	10-5/16
	1-3/8	1-5/8	2-3/4	2-3/4	4-1/2	-	1-5/8	9	9-7/8	10-9/16
	1-3/4	2	2-3/4	3	4-1/2	-	1-7/8	9-1/4	10-1/8	10-13/16
	2	2-1/4	2-3/4	3-1/8	4-1/2	-	2	9-3/8	10-1/4	10-15/16
	2-1/2	3	2-3/4	3-3/8	4-1/2	-	2-1/4	9-5/8	10-1/2	11-3/16
	3	3-1/2	2-3/4	3-3/8	4-1/2	-	2-1/4	9-5/8	10-1/2	11-3/16
	3-1/2	3-1/2	2-3/4	3-3/8	4-1/2	1-5/8	2-1/4	9-5/8	10-1/2	11-3/16
6	1-3/8	1-5/8	3-1/8	2-13/16	5	-	1-5/8	10-3/4	12-1/8	13-5/16
	1-3/4	2	3-1/8	3-1/16	5	-	1-7/8	11	12-3/8	13-9/16
	2	2-1/4	3-1/8	3-3/16	5	-	2	11-1/8	12-1/2	13-11/16
	2-1/2	3	3-1/8	3-7/16	5	-	2-1/4	11-3/8	12-3/4	13-15/16
	3	3-1/2	3-1/8	3-7/16	5	-	2-1/4	11-3/8	12-3/4	13-15/16
	3-1/2	3-1/2	3-1/8	3-7/16	5	-	2-1/4	11-3/8	12-3/4	13-15/16
	4	4	3-1/8	3-7/16	5	1-1/2	2-1/4	11-3/8	12-3/4	13-15/16

**Table A**

THE FOLLOWING BORE/ROD COMBINATIONS USE HEAD PLATE AND BRONZE GLANDS AS SHOWN AT RIGHT	
BORE	ROD DIAMETER (MM)
1-1/2	5/8 & 1
2	1 & 1-3/8
2-1/2	1-3/4
3-1/4	2
4	2-1/2
5	3-1/2
6	4

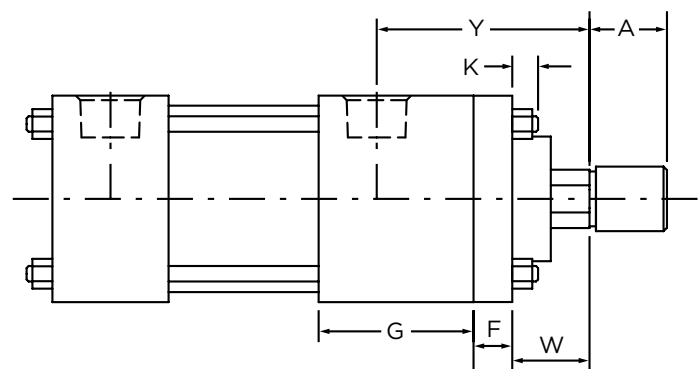

**NOTE:** Bolt-on glands not available on these combinations.  
**NOTE:** Threaded Bronze Gland used on all Model D Cylinders.  
 Bolt-on Gland used on all Model DG Cylinders.

**MODEL H (NFPA STD. NONE)**▲

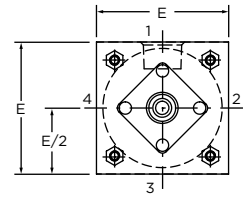
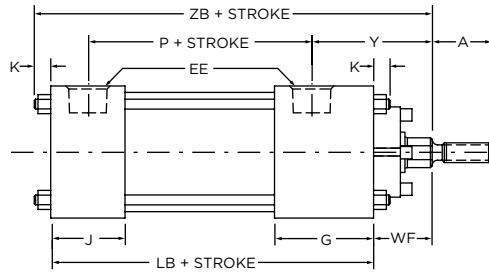
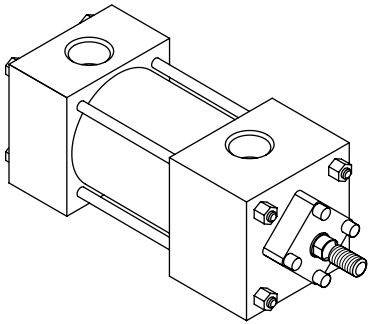

**MODEL XH (NFPA STD. NONE)**▲

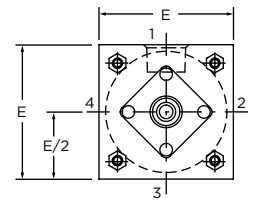
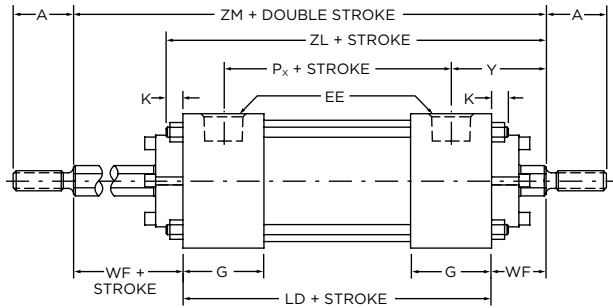
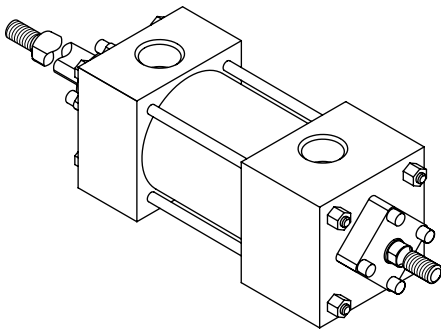

▲ = See Table A on page 127 for bore and rod combinations using head plates with threaded bronze glands.

**Table 1** These dimensions are constant regardless of rod diameter or stroke.

Double rod end models are designated by letter "X" preceding the model identification.

BORE DIA.	E	G	J	K	EE
1-1/2	2	1-1/2	1-1/8	1/4	3/8
2	2-1/2	1-1/2	1-1/8	3/8	3/8
2-1/2	3	1-1/2	1-1/8	5/16	3/8
3-1/4	3-3/4	1-3/4	1-1/4	7/16	1/2
4	4-1/2	1-3/4	1-1/4	7/16	1/2
5	5-1/2	1-3/4	1-1/4	1/2	1/2
6	6-1/2	2	1-1/2	9/16	3/4



# BASIC MODEL NO MOUNT CYLINDERS

1-1/2" THROUGH 6" DIAMETER

**Table 2** The dimensions given on this table are affected by the piston rod diameter and the stroke.

• = For piston rod dimensions see page 132.

BORE DIA.	ROD MM•	A	P	Px	Y	LB	LD	WF	ZB	ZL	ZM
1-1/2	5/8	3/4	2-1/8	2-1/4	1-15/16	3-5/8	4-1/8	1	4-7/8	5-3/8	6-1/8
	1	1-1/8	2-1/8	2-1/4	2-5/16	3-5/8	4-1/8	1-3/8	5-1/4	5-3/4	6-7/8
2	5/8	3/4	2-1/8	2-1/4	1-15/16	3-5/8	4-1/8	1	5	5-1/2	6-1/8
	1	1-1/8	2-1/8	2-1/4	2-5/16	3-5/8	4-1/8	1-3/8	5-3/8	5-7/8	6-7/8
	1-3/8	1-5/8	2-1/8	2-1/4	2-9/16	3-5/8	4-1/8	1-5/8	5-11/16	6-1/8	7-3/8
2-1/2	5/8	3/4	2-1/4	2-3/8	1-15/16	3-3/4	4-1/4	1	5-1/16	5-9/16	6-1/4
	1	1-1/8	2-1/4	2-3/8	2-5/16	3-3/4	4-1/4	1-3/8	5-7/16	5-15/16	7
	1-3/8	1-5/8	2-1/4	2-3/8	2-9/16	3-3/4	4-1/4	1-5/8	5-11/16	6-3/16	7-1/2
	1-3/4	2	2-1/4	2-3/8	2-13/16	3-3/4	4-1/4	1-7/8	5-15/16	6-7/16	8
3-1/4	1	1-1/8	2-1/2	2-1/2	2-1/2	4-1/4	4-3/4	1-3/8	6-1/16	6-9/16	7-1/2
	1-3/8	1-5/8	2-1/2	2-1/2	2-3/4	4-1/4	4-3/4	1-5/8	6-5/16	6-13/16	8
	1-3/4	2	2-1/2	2-1/2	3	4-1/4	4-3/4	1-7/8	6-9/16	7-1/16	8-1/2
	2	2-1/4	2-1/2	2-1/2	3-1/8	4-1/4	4-3/4	2	6-11/16	7-3/16	8-3/4
4	1	1-1/8	2-1/2	2-1/2	2-1/2	4-1/4	4-3/4	1-3/8	6-1/16	6-9/16	7-1/2
	1-3/8	1-5/8	2-1/2	2-1/2	2-3/4	4-1/4	4-3/4	1-5/8	6-5/16	6-13/16	8
	1-3/4	2	2-1/2	2-1/2	3	4-1/4	4-3/4	1-7/8	6-9/16	7-1/16	8-1/2
	2	2-1/4	2-1/2	2-1/2	3-1/8	4-1/4	4-3/4	2	6-11/16	7-3/16	8-3/4
	2-1/2	3	2-1/2	2-1/2	3-3/8	4-1/4	4-3/4	2-1/4	6-15/16	7-7/16	9-1/4
5	1	1-1/8	2-3/4	2-3/4	2-1/2	4-1/2	5	1-3/8	6-3/8	6-7/8	7-3/4
	1-3/8	1-5/8	2-3/4	2-3/4	2-3/4	4-1/2	5	1-5/8	6-5/8	7-1/8	8-1/4
	1-3/4	2	2-3/4	2-3/4	3	4-1/2	5	1-7/8	6-7/8	7-3/8	8-3/4
	2	2-1/4	2-3/4	2-3/4	3-1/8	4-1/2	5	2	7	7-1/2	9
	2-1/2	3	2-3/4	2-3/4	3-3/8	4-1/2	5	2-1/4	7-1/4	7-3/4	9-1/2
	3	3-1/2	2-3/4	2-3/4	3-3/8	4-1/2	5	2-1/4	7-1/4	7-3/4	9-1/2
	3-1/2	3-1/2	2-3/4	2-3/4	3-3/8	4-1/2	5	2-1/4	7-1/4	7-3/4	9-1/2
6	1-3/8	1-5/8	3-1/8	3-1/8	2-13/16	5	5-1/2	1-5/8	7-3/16	7-11/16	8-3/4
	1-3/4	2	3-1/8	3-1/8	3-1/16	5	5-1/2	1-7/8	7-7/16	7-15/16	9-1/4
	2	2-1/4	3-1/8	3-1/8	3-3/16	5	5-1/2	2	7-9/16	8-1/16	9-1/2
	2-1/2	3	3-1/8	3-1/8	3-7/16	5	5-1/2	2-1/4	7-13/16	8-5/16	10
	3	3-1/2	3-1/8	3-1/8	3-7/16	5	5-1/2	2-1/4	7-13/16	8-5/16	10
	3-1/2	3-1/2	3-1/8	3-1/8	3-7/16	5	5-1/2	2-1/4	7-13/16	8-5/16	10
	4	4	3-1/8	3-1/8	3-7/16	5	5-1/2	2-1/4	7-13/16	9-5/16	10

## MODEL H (NFPA STD. NONE)

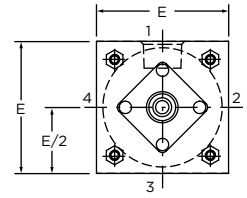
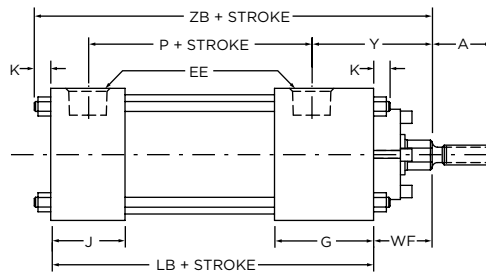
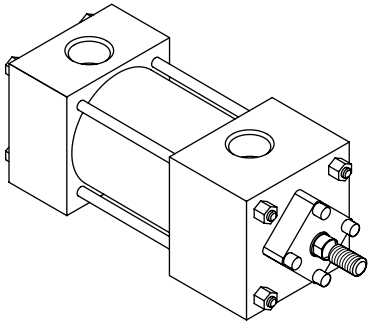

## MODEL XH (NFPA STD. NONE)

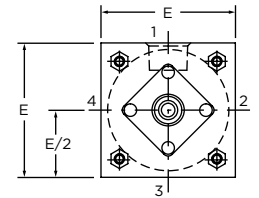
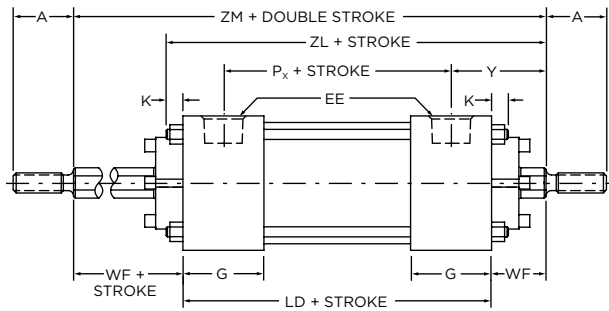
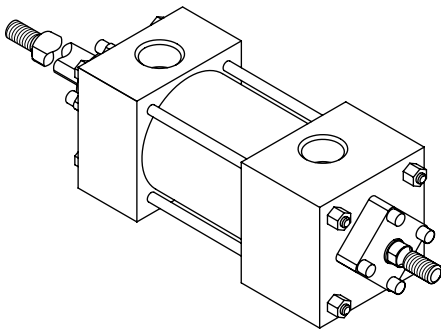

**Table 1** These dimensions are constant regardless of rod diameter or stroke.

Double rod end models are designated by letter "X" preceding the model identification.

BORE DIA.	E	G	J	K	EE
8	8-1/2	2	1-1/2	5/8	3/4
10	10-5/8	2-1/4	2	3/4	1
12	12-3/4	2-1/4	2	3/4	1
14	14-3/4	2-3/4	2-1/4	7/8	1-1/4
16	17-1/2	3	3	1	1-1/4
18	19-1/2	3-7/16	3-7/16	1-1/8	1-1/2
20	21-3/4	3-15/16	3-15/16	1-1/4	2

# BASIC MODEL NO MOUNT CYLINDERS

8" THROUGH 20" DIAMETER

**Table 2** The dimensions given on this table are affected by the piston rod diameter and the stroke.

• = For piston rod dimensions see page 132.

BORE DIA.	ROD MM•	A	P	Y	LB	LD	WF	ZB	ZL	ZM
8	1-3/8	1-5/8	3-1/4	2-13/16	5-1/8	5-5/8	1-5/8	7-3/8	7-7/8	8-7/8
	1-3/4	2	3-1/4	3-1/16	5-1/8	5-5/8	1-7/8	7-5/8	8-1/8	9-3/8
	2	2-1/4	3-1/4	3-3/16	5-1/8	5-5/8	2	7-3/4	8-1/4	9-5/8
	2-1/2	3	3-1/4	3-7/16	5-1/8	5-5/8	2-1/4	8	8-1/2	10-1/8
	3	3-1/2	3-1/4	3-7/16	5-1/8	5-5/8	2-1/4	8	8-1/2	10-1/8
	3-1/2	3-1/2	3-1/4	3-7/16	5-1/8	5-5/8	2-1/4	8	8-1/2	10-1/8
	4	4	3-1/4	3-7/16	5-1/8	5-5/8	2-1/4	8	8-1/2	10-1/8
	4-1/2	4-1/2	3-1/4	3-7/16	5-1/8	5-5/8	2-1/4	8	8-1/2	10-1/8
	5	5	3-1/4	3-7/16	5-1/8	5-5/8	2-1/4	8	8-1/2	10-1/8
10	5-1/2	5-1/2	3-1/4	3-7/16	5-1/8	5-5/8	2-1/4	8	8-1/2	10-1/8
	1-3/4	2	4	3-3/16	6-3/8	6-5/8	1-7/8	9	9-1/4	10-3/8
	2	2-1/4	4	3-5/16	6-3/8	6-5/8	2	9-1/8	9-3/8	10-5/8
	2-1/2	3	4	3-9/16	6-3/8	6-5/8	2-1/4	9-3/8	9-5/8	11-1/8
	3	3-1/2	4	3-9/16	6-3/8	6-5/8	2-1/4	9-3/8	9-5/8	11-1/8
	3-1/2	3-1/2	4	3-9/16	6-3/8	6-5/8	2-1/4	9-3/8	9-5/8	11-1/8
	4	4	4	3-9/16	6-3/8	6-5/8	2-1/4	9-3/8	9-5/8	11-1/8
	4-1/2	4-1/2	4	3-9/16	6-3/8	6-5/8	2-1/4	9-3/8	9-5/8	11-1/8
	5	5	4	3-9/16	6-3/8	6-5/8	2-1/4	9-3/8	9-5/8	11-1/8
12	5-1/2	5-1/2	4	3-9/16	6-3/8	6-5/8	2-1/4	9-3/8	9-5/8	11-1/8
	2	2-1/4	4-1/2	3-5/16	6-7/8	7-1/8	2	9-5/8	9-7/8	11-1/8
	2-1/2	3	4-1/2	3-9/16	6-7/8	7-1/8	2-1/4	9-7/8	10-1/8	11-5/8
	3	3-1/2	4-1/2	3-9/16	6-7/8	7-1/8	2-1/4	9-7/8	10-1/8	11-5/8
	3-1/2	3-1/2	4-1/2	3-9/16	6-7/8	7-1/8	2-1/4	9-7/8	10-1/8	11-5/8
	4	4	4-1/2	3-9/16	6-7/8	7-1/8	2-1/4	9-7/8	10-1/8	11-5/8
	4-1/2	4-1/2	4-1/2	3-9/16	6-7/8	7-1/8	2-1/4	9-7/8	10-1/8	11-5/8
	5	5	4-1/2	3-9/16	6-7/8	7-1/8	2-1/4	9-7/8	10-1/8	11-5/8
14	5-1/2	5-1/2	4-1/2	3-9/16	6-7/8	7-1/8	2-1/4	9-7/8	10-1/8	11-5/8
	2-1/2	3	5-1/2	3-13/16	8-1/8	8-5/8	2-1/4	11-1/4	11-3/4	13-1/8
	3	3-1/2	5-1/2	3-13/16	8-1/8	8-5/8	2-1/4	11-1/4	11-3/4	13-1/8
	3-1/2	3-1/2	5-1/2	3-13/16	8-1/8	8-5/8	2-1/4	11-1/4	11-3/4	13-1/8
	4	4	5-1/2	3-13/16	8-1/8	8-5/8	2-1/4	11-1/4	11-3/4	13-1/8
	4-1/2	4-1/2	5-1/2	3-13/16	8-1/8	8-5/8	2-1/4	11-1/4	11-3/4	13-1/8
	5	5	5-1/2	3-13/16	8-1/8	8-5/8	2-1/4	11-1/4	11-3/4	13-1/8
16	5-1/2	5-1/2	5-1/2	3-13/16	8-1/8	8-5/8	2-1/4	11-1/4	11-3/4	13-1/8
	2-1/2	3	5-7/8	3-15/16	9-1/4	9-1/4	2-1/4	12-1/2	12-1/2	13-3/4
	3	3-1/2	5-7/8	3-15/16	9-1/4	9-1/4	2-1/4	12-1/2	12-1/2	13-3/4
	3-1/2	3-1/2	5-7/8	3-15/16	9-1/4	9-1/4	2-1/4	12-1/2	12-1/2	13-3/4
	4	4	5-7/8	3-15/16	9-1/4	9-1/4	2-1/4	12-1/2	12-1/2	13-3/4
	4-1/2	4-1/2	5-7/8	3-15/16	9-1/4	9-1/4	2-1/4	12-1/2	12-1/2	13-3/4
	5	5	5-7/8	3-15/16	9-1/4	9-1/4	2-1/4	12-1/2	12-1/2	13-3/4
18	5-1/2	5-1/2	5-7/8	3-15/16	9-1/4	9-1/4	2-1/4	12-1/2	12-1/2	13-3/4
	3-1/2	3-1/2	6	4-3/8	10-1/4	10-1/4	2-1/4	13-5/8	13-5/8	14-3/4
	4	4	6	4-3/8	10-1/4	10-1/4	2-1/4	13-5/8	13-5/8	14-3/4
	4-1/2	4-1/2	6	4-3/8	10-1/4	10-1/4	2-1/4	13-5/8	13-5/8	14-3/4
	5	5	6	4-3/8	10-1/4	10-1/4	2-1/4	13-5/8	13-5/8	14-3/4
20	5-1/2	5-1/2	6	4-3/8	10-1/4	10-1/4	2-1/4	13-5/8	13-5/8	14-3/4
	4	4	7-1/8	4-9/16	11-3/4	11-3/4	2-1/4	15-1/4	15-1/4	16-1/4
	4-1/2	4-1/2	7-1/8	4-9/16	11-3/4	11-3/4	2-1/4	15-1/4	15-1/4	16-1/4
	5	5	7-1/8	4-9/16	11-3/4	11-3/4	2-1/4	15-1/4	15-1/4	16-1/4
	5-1/2	5-1/2	7-1/8	4-9/16	11-3/4	11-3/4	2-1/4	15-1/4	15-1/4	16-1/4

**CLASS 6 CYLINDER PISTON ROD END DIMENSIONAL DATA**

**NOTE:** Rod threads are Class UNF-2A or 2B unless specifically quoted otherwise.

**NOTE:** Standard (smallest) diameter rods in each bore size with standard (#4) thread are **STOCKED** in even-inch stroke increments 1" through 20". Cushioned and non-cushioned. **This translates to MUCH QUICKER delivery.**

**ROD END TYPE NO. 1**

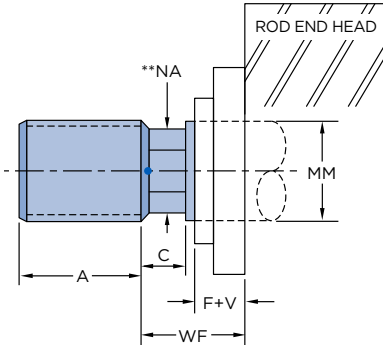

**ROD END TYPE NO. 3 & NO. 4**

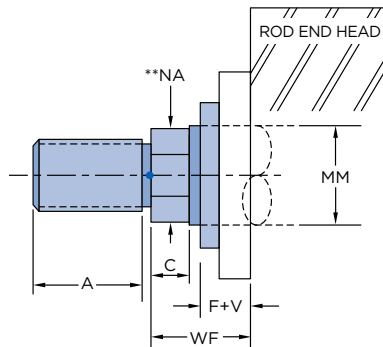

**ROD END TYPE NO. 5**

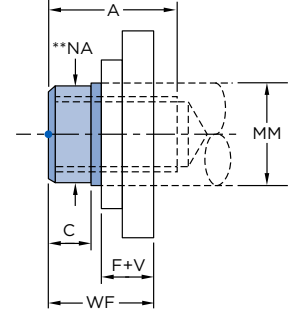

\*\* = Dimension NA is .060 under MM diameter dimension.

DIA. ROD MM	ROD END TYPE				A	C	D <sup>■</sup>	F+V	WF
	NO. 1	NO. 3	NO. 4*	NO. 5					
5/8	5/8-18	1/2-20	7/16-20	7/16-20	3/4	3/8	1/2	5/8	1
1	1-14	7/8-14	3/4-16	3/4-16	1-1/8	1/2	7/8	3/4	1-3/8
1-3/8	1-3/8-12	1-1/4-12	1-14	1-14	1-5/8	5/8	1-1/8	1	1-5/8
1-3/4	1-3/4-12	1-1/2-12	1-1/4-12	1-1/4-12	2	3/4	1-1/2	3/4	1-7/8
2	2-12	1-3/4-12	1-1/2-12	1-1/2-12	2-1/4	7/8	1-11/16	7/8	2
2-1/2	2-1/2-12	2-1/4-12	1-7/8-12	1-7/8-12	3	1	2-1/16	1-1/16	2-1/4
3	3-12	2-3/4-12	2-1/4-12	2-1/4-12	3-1/2	1	2-5/8	1-1/8	2-1/4
3-1/2	3-1/2-12	3-1/4-12	2-1/2-12	2-1/2-12	3-1/2	1	3	1-1/8	2-1/4
4	4-12	3-3/4-12	3-12	3-12	4	1	3-3/8	1-1/4	2-1/4
4-1/2	4-1/2-12	4-1/4-12	3-1/4-12	3-1/4-12	4-1/2	1	3-7/8	1-1/4	2-1/4
5	5-12	4-3/4-12	3-1/2-12	3-1/2-12	5	1	4-1/4	1-1/4	2-1/4
5-1/2	5-1/2-12	5-1/4-12	4-12	4-12	5-1/2	1	4-5/8	1-1/4	2-1/4

- = Type 4 thread sized for clevis and rod eye accessories.
- = Dimension D is size across wrench flats.

**ROD END TYPE NO. 6**

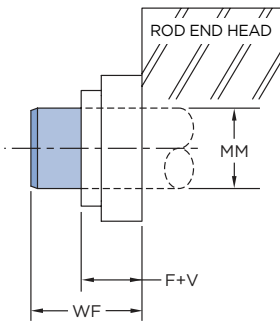

DIA. ROD MM	F+V	WF
5/8	5/8	1
1	3/4	1-3/8
1-3/8	1	1-5/8
1-3/4	3/4	1-7/8
2	7/8	2
2-1/2	1-1/16	2-1/4
3	1-1/8	2-1/4
3-1/2	1-1/8	2-1/4
4	1-1/4	2-1/4
4-1/2	1-1/4	2-1/4
5	1-1/4	2-1/4
5-1/2	1-1/4	2-1/4

**ROD END TYPE NO. 7**

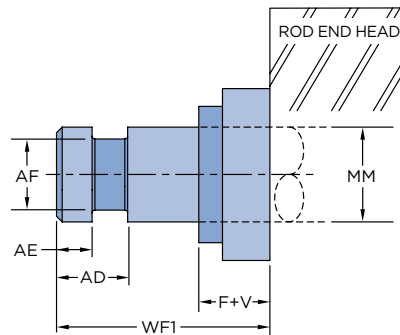

DIA. ROD MM	F+V	WF1	AD	AE	AF
5/8	5/8	1-3/4	5/8	1/4	3/8
1	3/4	2-1/2	15/16	3/8	11/16
1-3/8	1	2-3/4	1-1/16	3/8	7/8
1-3/4	3/4	3-1/8	1-5/16	1/2	1-1/8
2	7/8	3-3/4	1-11/16	5/8	1-3/8
2-1/2	1-1/16	4-1/2	1-15/16	3/4	1-3/4
3	1-1/8	4-7/8	2-7/16	7/8	2-1/4
3-1/2	1-1/8	5-5/8	2-11/16	1	2-1/2
4	1-1/4	5-3/4	2-11/16	1	3
4-1/2	1-1/4	6-1/2	3-3/16	1-1/2	3-1/2
5	1-1/4	6-5/8	3-3/16	1-1/2	3-7/8
5-1/2	1-1/4	7-1/2	3-15/16	1-7/8	4-3/8

## EYE BRACKET

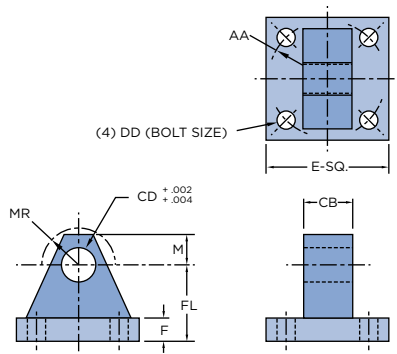

CYL. DIA.	E	F	M	AA	CB	CD	DD	FL	MR	PART NO.
1-1/2-2-2-1/2	2-1/2	3/8	1/2	2.30	3/4	1/2	3/8	1-1/8	5/8	2716L47
3-1/4-4-5	3-1/2	5/8	3/4	3.61	1-1/4	3/4	1/2	1-7/8	7/8	2719L32
6-8	4-1/2	7/8	1	4.60	1-1/2	1	5/8	2-3/8	1-1/4	2720L33
10	5	7/8	1-3/8	5.40	2	1-3/8	5/8	3	1-5/8	2721L34
12	6-1/2	1-1/8	1-3/4	7.00	2-1/2	1-3/4	7/8	3-3/8	2	2722L35
14-16	7-1/2	1-7/16	2	8.10	2-1/2	2	1	3-15/16	2-3/8	2723L36
18	8-1/2	1-5/8	2-1/2	9.30	3	2-1/2	1-1/8	4-5/8	3	2724L37
20	9-1/2	2	2-3/4	10.61	3	3	1-1/4	5-1/4	3-1/4	2725L38

## MOUNTING BRACKET

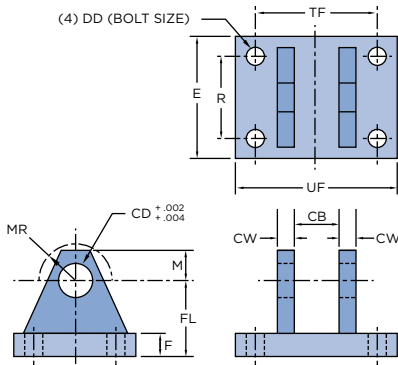

CYL. DIA.	E	F	M	R	CB	CD	CW	DD	FL	MR	TF	UF	PART NO.
1-1/2-2-2-1/2	2-1/2	3/8	1/2	1.63	3/4	1/2	1/2	3/8	1-1/8	5/8	2-3/4	3-1/2	2683L47
3-1/4-4-5	3-1/2	5/8	3/4	2.55	1-1/4	3/4	5/8	1/2	1-7/8	7/8	3-3/4	4-3/4	2684L47
6-8	4-1/2	7/8	1	3.25	1-1/2	1	3/4	5/8	2-3/8	1-1/4	4-1/2	5-3/4	2685L47
10	5	7/8	1-3/8	3.82	2	1-3/8	1	5/8	3	1-5/8	5-1/2	6-3/4	2686L47
12	6-1/2	1-1/8	1-3/4	4.95	2-1/2	1-3/4	1-1/4	7/8	3-3/8	2	7	8-1/2	2687L47
14-16	7-1/2	1-7/16	2	5.73	2-1/2	2	1-1/4	1	3-15/16	2-3/8	7-1/2	9-1/4	2688L47
18	8-1/2	1-5/8	2-1/2	6.58	3	2-1/2	1-1/2	1-1/8	4-5/8	3	8-1/2	10-1/2	2689L47
20	9-1/2	2	2-3/4	7.50	3	3	1-1/2	1-1/4	5-1/4	3-1/4	8-3/4	10-3/4	2690L47

## EYE (FEMALE)

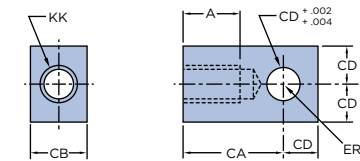

KK	A	CA	CB	CD	ER	PART NO.
7/16-20	3/4	1-1/2	3/4	1/2	5/8	1810L59
3/4-16	1-1/8	2-1/16	1-1/4	3/4	1-1/16	1812L59
1-14	1-5/8	2-13/16	1-1/2	1	1-7/16	1813L59
1-1/4-12	2	3-7/16	2	1-3/8	2	1814L59
1-1/2-12	2-1/4	4	2-1/2	1-3/4	2-1/16	1815L59
1-7/8-12	3-1/2	5	2-1/2	2	2-1/4	1817L59
2-1/4-12	3-1/2	5-13/16	3	2-1/2	2-7/8	1820L59
2-1/2-12	3-1/2	6-1/8	3	3	3-1/8	1821L59
3-1/4-12	4-1/2	7-5/8	4	3-1/2	3-7/8	1824L59

## PIVOT - PIN

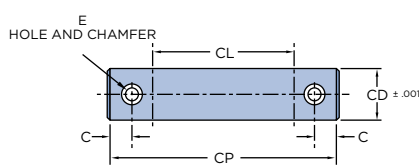

CYL. DIA.	C	E	CD	CP	CL	PART NO.
1-1/2-2-2-1/2	3/16	1/8	1/2	2-3/8	1-3/4	3222L47-1
3-1/4-4-5	1/4	3/16	3/4	3-1/8	2-1/2	3222L47-2
6-8	1/4	3/16	1	3-5/8	3	3222L47-3
10	1/4	3/16	1-3/8	4-3/4	4	3222L47-4
12	1/4	3/16	1-3/4	5-13/16	5	3222L47-5
14	5/16	1/4	2	5-13/16	5	3222L47-6
16	5/16	1/4	2-1/2	6-7/8	6	3222L47-8
18-20	5/16	1/4	3	6-7/8	6	3222L47-7
ROD EYE & CLEVIS	3/8	1/4	3-1/2	9-1/4	8	3222L47-9

## CLEVIS (FEMALE)

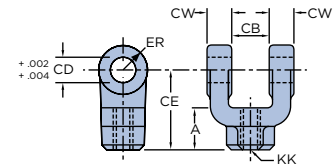

KK	A	CB	CD	CE	CW	ER	PART NO.
7/16-20	3/4	3/4	1/2	1-1/2	1/2	1/2	2834L59
3/4-16	1-1/8	1-1/4	3/4	2-3/8	5/8	3/4	2835L59
1-14	1-5/8	1-1/2	1	3-1/8	3/4	1	2836L59
1-1/4-12	2	2	1-3/8	4-1/8	1	1-3/8	2837L59
1-1/2-12	2-1/4	2-1/2	1-3/4	4-1/2	1-1/4	1-3/4	2838L59
1-7/8-12	3	2-1/2	2	5-1/2	1-1/4	2	2839L59
2-1/4-12	3-1/2	3	2-1/2	6-1/2	1-1/2	2-1/2	2840L59
2-1/2-12	3-1/2	3	3	6-3/4	1-1/2	2-3/4	2841L59
3-1/4-12	4-1/2	4	3-1/2	8-1/2	2	3-1/2	2842L59

## SPHERICAL ROD EYE

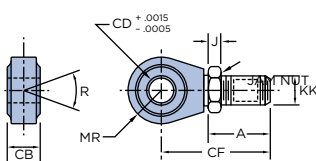

CYL. DIA.	A	J	R	CB	CD	CF	KK	MR	THRUST RATING	PART NO.
1-1/2-2-2-1/2	1-1/2	1/4	12°	5/8	1/2	2-7/16	7/16-20	11/16	5,500#	2825L48-1
1-1/2-2-2-1/2	15/16	1/4	12°	5/8	1/2	1-7/8	7/16-20	11/16	5,500#	2825L48-2
3-1/4-4-5	1-3/4	7/16	13-1/2°	7/8	3/4	2-7/8	3/4-16	7/8	10,000#	2825L48-3
6-8	2-1/8	9/16	14°	1-3/8	1	4-1/8	1-14	1-7/16	12,000#	2825L48-4
8	2-1/8	9/16	14°	1-3/8	1	4-1/8	1-14	1-7/16	19,000#	2825L48-5

For 8" Cyl. Diameter — Hydraulics only.



**LONG LIFE/HIGH PERFORMANCE**

**FEATURES AND ADVANTAGES**

- Adjustable mounting allows switches to be located anywhere within range of piston travel.
- Several switches may be mounted to control or initiate any sequence function.
- No externally moving parts to wear or maintain.
- Suited for use in plant environments where dirt and contamination create difficulties for electromechanical and other types of controls.
- Neon Indicator Light provides convenient means for positioning and troubleshooting switch and circuits.
- Suitable for AC service only.

**WORKING PRINCIPLE**

Basically the Reed Switch consists of two overlapping ferro magnetic blades (reeds). The reeds are hermetically sealed inside a glass tube leaving a small air gap between them.

Since the reeds are magnetic, they will assume opposite polarity and be attracted to each other when influenced by a magnetic field. Sufficient magnetic flux density will cause the reeds to flex and contact each other. When the magnetic field is removed, they will again spring apart to their normal positions.

The cylinder/Reed Switch combination operates by using a magnetic band on the cylinder piston, which closes the externally mounted reed switch, as it approaches. When the piston moves away again the switch opens.

Proper application of this versatile Reed Switch can offer millions of cycles of trouble-free operation.

**3 AMP REED SWITCH SPECIFICATIONS**

Circuit - Normally open - SPST (Form A)  
VA (Max) - 360  
Switching voltage - 65-120 VAC (50/60 Hz)  
Current (Break) - 3.0 Amp  
Leakage - 1.7 mA  
Response Time - 15 ms On, 0.83 ms Off  
Switch Burden Current - 5 mA

**Note:** All incandescent loads derate switch capacity to 10% due to inrush current.

Moisture and dust proof (no NEMA rating)

**SHOCK RATING**

The basic switch can withstand up to 60 G maximum in the direction of contact closure without misfire or malfunction.

**VIBRATION SENSITIVITY**

Switch will withstand amplitude of 30 G at frequencies up to 6000 Hz without misfire. False operation can occur at vibration frequency levels higher than 6000 Hz.

**OPERATING TEMPERATURE**

-40°F to +170°F for standard cable.

**CABLE SPECIFICATION**

The conductors are tinned copper with polyethylene insulation, conductors are cabled with a rayon braid, a tinned copper braided shield and a chrome vinyl jacket that is resistant to hydraulic fluids.

**SWITCH WIRING SCHEMATIC**

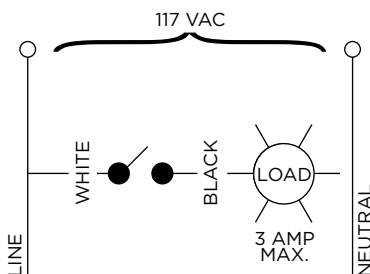

**CAUTION**

**Do not connect switch without a load. Permanent damage to switch will result.**

**NOTE:** Switch is internally protected against failure due to normal electrical transient levels. However, it may be necessary to use additional transient protection if high levels exist.

# PROXIMITY POSITION INDICATOR SWITCH

## HYDRAULIC OR PNEUMATIC CYLINDER OPERATIONS

### SQUARE-HEAD CYLINDERS

#### NOPAK Cylinder with Switch (pictured)

- Non-contact design
- Long life
- Pressures to 3000 PSI
- High reliability
- Versatile, easy operation



For positive full indication of stroke Hydraulic and Pneumatic Cylinders

### WORKING PRINCIPLE

NOPAK Position Indicator Switches are easily mounted in both hydraulic and pneumatic cylinder heads to confirm the position of the piston in either extended or retracted positions. Designed for versatility, NOPAK switches can be mounted in virtually any position. When inserted in the cylinder head, the switch senses the cushion sleeve's position at end of stroke. NOPAK's threaded switch screws easily into the cylinder heads making it a natural for accurate confirmation. Totally self-contained, the switch will not be contaminated by dirt, oil, grease, and most corrosive atmospheres. The non-contact design also eliminates the need for linkage or external actuators. Heavy-duty construction allows the switch to withstand up to 3000 PSI of external pressure (higher pressure available upon request).

### DESIGN FEATURES

- **Very Economical** - Easy to install, NOPAK Position Indicator Switches are totally self-contained, eliminating external power supply requirements.
- **Enclosure** - 300 Series Stainless Steel provides reliable performance under even the most adverse conditions.
- **Hermetically Sealed** - To ensure a clean, stable contact environment, the entire assembly is completely evacuated, then back-filled under pressure.
- **Long Life** - Tested to over 1,000,000 cycles. (Actual life varies with load.)
- **High Contact Pressure** - Heavy vibrations will not cause false operations of the switch. Good electrical characteristics for dry circuit and low load applications.

### SPECIFICATIONS

#### CONTACT ARRANGEMENT:

Single Pole Double Throw SPDT (Form C)

#### CONTACT RATINGS:

UL Rated (NEMA Type 1)

240 VAC @ 2A

250 VDC @ 0.5A Resistive

Although not UL General Purpose, switch is suitable for: 24 VDC @ 50 mA

#### TEMPERATURE RANGE:

-40°F (-40°C) to 221°F (105°C)

#### RESPONSE TIME: 8 milliseconds

#### REPEATABILITY:

0.002" (0.05 mm) of setpoint under identical operating conditions.

Consult Factory for other contact arrangements, ratings, terminations, and approvals.

### PROXIMITY POSITION INDICATOR SWITCH PRINCIPLES OF OPERATION

The NOPAK Proximity Limit Switch is based on an operating principle which utilizes "new," high energy, rare earth magnets to provide an end sensing range fixed at approximately .072" (1.83 mm) with a ferrous actuator. Use of an external magnet increases this appreciably. The differential (hysteresis) is approximately half of the sensing range.

When time, accuracy, and dependability count... you can count on a NOPAK Indicator Switch. Maintenance free: engineered for precision, performance and reliability.

**NOTE:** This is not a 'reed' type switch.

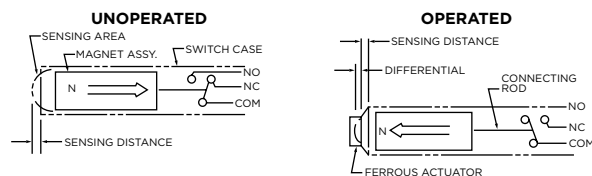

Wiring Color Code: Black = Common, Red = Normally Closed; Blue = Normally Open

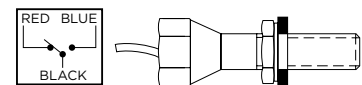

Switch enclosure incorporates a 1/2-14 NPT conduit connection. Switch wire connections are a potted 3 wire cable 18" long. External mounting threads are locked to cylinder head port with a hex jam nut and seal.

Where installation height is limited some switches are available with side-potted leads. Consult factory.

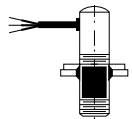

**AVAILABLE IN:**  
**CLASS 6** (pictured)  
**CLASS 3**

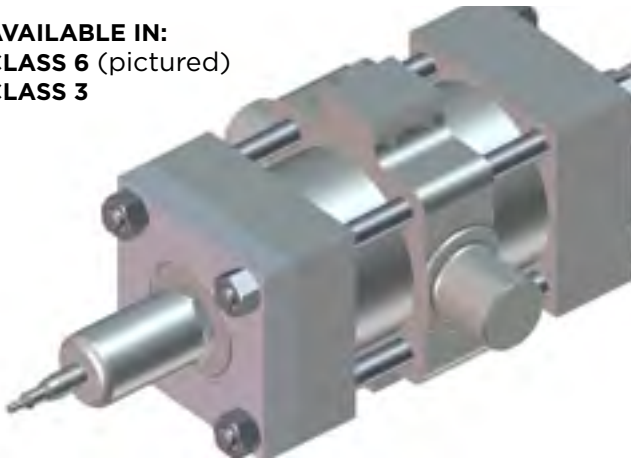

### DESIGN AND PERFORMANCE FEATURES

- Non-contacting design - no wear, no friction, no noise and no adjustments.
- Completely solid state.
- Both analog and digital outputs are available.
- Quartz crystal time reference.
- Withstands corrosive environments and pressures up to 3000 PSI.
- Feedback sensor inside cylinder is protected from debris and mechanical damage.
- Absolute output, not incremental - no loss of position at restart.

**NOPAK** has a linear displacement transducer that is designed for use in air or hydraulic cylinder actuators. The transducer, available in lengths up to thirty feet, is threaded into the cylinder and sealed to withstand the pressures of hydraulic fluid. A permanent magnet is mounted on the piston end of the cylinder rod, and is used to determine the position of the piston inside the cylinder. Double ended rods not applicable.

### HERE'S HOW IT WORKS:

It simply measures the time interval required for an electric current pulse to travel between two points. The two points of measurement are the fixed magnet located on the piston position and the sensor at the end of the transducer probe. This concept has been successful in eliminating considerable expense for potentiometers, tach generators, encoders, racks, pinions, and other special hardware.

### ADVANTAGES:

Includes a non-contact operation, no wear, no noise generation, high reliability, infinite resolution (analog), high linearity (.05%), excellent repeatability (.002%), and direct digital output if required.

LDT Systems can be adapted to all NOPAK P6 and H6 cylinder diameters with a 1-3/8" diameter rod or larger.

We welcome the opportunity to discuss your applications and help you supply your needs.

### NLDT SPECIFICATIONS

Electrical stroke	Standard - up to 25 feet.
Null	Positioned as required.
Null adjustment	2% of total stroke nominal.
Scale adjustment	1% of total stroke nominal.
Non-linearity	Less than $\pm 0.05\%$ of full range.
Repeatability	Better than $\pm 0.001\%$ of full range.
Temperature coefficient of scale factor	Transducer - Less than 0.00011 inch/ $^{\circ}$ F + [3 ppm/ $^{\circ}$ F per inch of full stroke]. Analog Output Module -20 ppm/ $^{\circ}$ F.
Frequency response	Stroke dependent. 200 Hz to 50 Hz is typical for lengths of 12 inch to 100 inch respectively - wider response frequencies are available upon request. For digital systems, output is updated at discrete intervals.
Hysteresis	Less than 0.0008 in. maximum.
Output	Analog -0 to +10 VDC, 4 to 20 mA ungrounded, (others available). Digital-pulse width modulated signal, TTL compatible.
Operating impedance	10 ohms.
Operating temperature range	-35 $^{\circ}$ F to 150 $^{\circ}$ F (transducer probe to 180 $^{\circ}$ F).
Storage temperature range	-40 $^{\circ}$ F to 180 $^{\circ}$ F.
Operation in hydraulic fluid	The .375 inch dia. transducer probe is capable of operating in hydraulic fluid and will withstand 3,000 psi operating pressure.



### HOW TO ORDER

#### ORDERING CODE

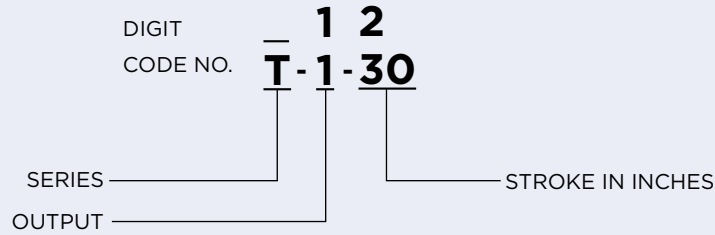

DIGIT	DESCRIPTION
<b>FIRST</b>	<b>OUTPUT</b> <ol style="list-style-type: none"> <li>0 to +10 VDC w/Analog Output Module</li> <li>0 to +10 VDC w/built-in Analog Personality Module (Eliminates separate Analog Output Module)</li> <li>4 to 20 MA grounded w/Analog Output Module</li> <li>Half digital w/Digital Personality Module</li> <li>Full digital w/Digital Personality Module and Digital Counter Card. Specify Binary or BCD.</li> <li>Digital with RS422 Personality Module</li> <li>Others (specify)</li> </ol>
<b>SECOND</b>	<b>ELECTRICAL STROKE IN INCHES (Example: 12.75 inches)</b> 1 - 1 Inch through 300 - 300 Inch (25 foot maximum)

**When ordering: Code Number must be completed using options listed above.**

For further detailed information contact your NOPAK distributor.

#### ALSO AVAILABLE

**Servo or Proportional Valve Footprint**

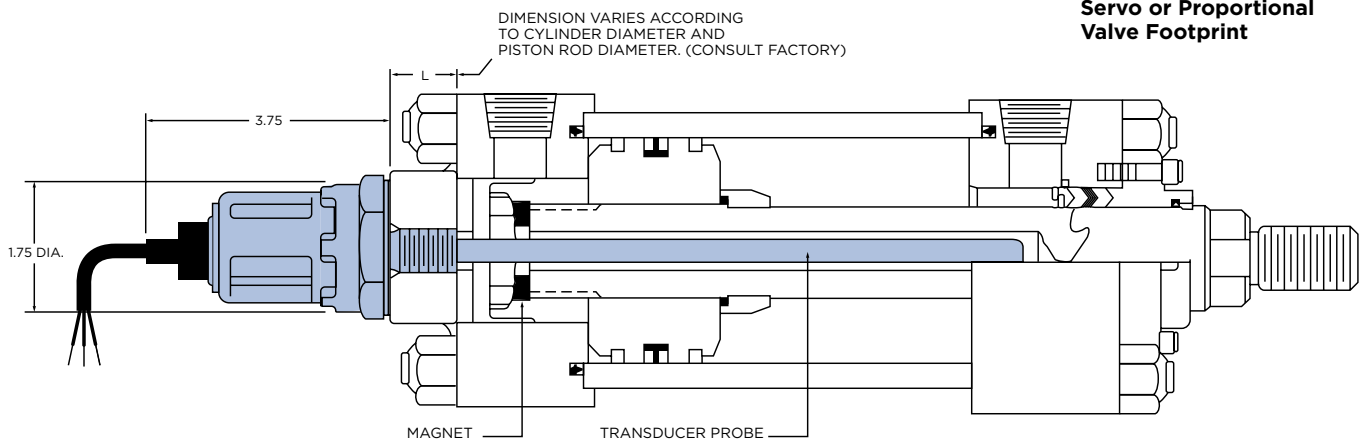

NOPAK Class 6 bore-rated cylinders are identified as P6 for air and H6 for hydraulic service. Please refer to Pressure Ratings (PSI) on page 96. Cylinders 1-1/2" through 10" diameter bore are assembled from standard inventory components. Special design and large diameter Class 6 cylinders are available. Send us your specifications.

### OPERATING TEMPERATURES AND MEDIA

Class P6 air and H6 hydraulic cylinders equipped with standard Type A packings may be operated at temperatures from -20°F to 250°F air, water or oil. The following chart relates in a simplified general purpose manner the limitations and uses of available piston and rod packings.

PACKING TYPE	
A	B
-20°F to +250°F Std. Hyd. Oil	-20°F to +375°F Std. Hyd. Oil
Air	Air
Water (not steam)	
Water Glycol Fire Resistant Fluid	Phosphate Ester Fire Resistant Fluid

*For specific media and temperature or conditions exceeding the chart ratings, consult NOPAK Engineering Department.*

Applications involving Fire Resistant Fluids must be so specified for compatible component materials. When considering temperature, remember that as the temperature increases (within the rated limits) the packing life decreases.

### INTERCHANGEABILITY

Class 6 cylinders are dimensionally interchangeable with other square-head cylinders of the same pressure classification. Construction and performance are in conformance with applicable NFPA recommended standards.

For P6 (pneumatic) cylinders with Integral Limit Switch(es), see page 134.

### CUSHIONS

NOPAK Class 6 cylinders are available with adjustable cushions on either or both ends, or non-cushion.

The purpose of a cushion is to slow down piston speed at the end of the stroke, eliminating hammer and noise. Where standard cushions are inadequate for unusual requirements, special cushions possibly requiring longer-than-standard heads can be furnished at additional charge. Very rapid cushioning of high speed movement may require deceleration valves.

The purpose of the ball check in the cushion mechanism is to allow fluid to pass to the piston face without obstruction (while the cushion sleeve is still within the bore in the head). This results in essential quick starting of the piston. Cushion adjusting screws serve to bypass the fluid from the trapped section between the piston and the cylinder head when the cushion sleeve has entered the bore. Turning the needle inward against the seat results in maximum cushion intensity. Backing up on the needle decreases the effect.

### CYLINDER PORT LOCATION

Inlet ports are located in Position 1 as standard (see rod end view on dimension drawings). They can however, be located at other numbered locations on application. Extra inlets furnished at additional charge. Oversize and special inlets require dimensions and quotation on application.

### WATER SERVICE

Special cylinders can be built for water service. Due to the uncertainty of action of water supply on some materials, responsibility for premature failure due to corrosion, mineral deposits or electrolysis cannot be accepted.

**TABLE A - TIE ROD TORQUE CHART  
CLASS P6 AIR AND H6 HYDRAULIC CYLINDERS**

CYLINDER DIAMETER	NO. OF TIE RODS	TIE ROD SIZE	P6 CYLINDER TORQUE FT LBS	H6 CYLINDER TORQUE FT LBS
1-1/2	4	1/4	3	7
2	4	5/16	7	14
2-1/2	4	5/16	7	14
3-1/4	4	3/8	15	30
4	4	3/8	15	30
5	4	1/2	30	60
6	4	1/2	30	60
8	4	5/8	60	150
10	4	3/4	100	260
12	4	3/4	100	260
14	4	7/8	170	400
16	8	1	260	600
18	8	1-1/8	300	850
20	8	1-1/4	450	1000

**TABLE B - VOLUME OF OIL  
PER 12" OF STROKE**

CYLINDER BORE	BLIND END DISPLACEMENT		ROD END DISPLACEMENT			
	AREA (SQ. IN.)	GALS./FOOT OF STROKE	NET AREA (SQ. IN.) WITH R ROD	GALS./FOOT OF STROKE	NET AREA (SQ. IN.) WITH HR ROD	GALS./FOOT OF STROKE
1-1/2	1.767	.0918	1.460	.0758	.982	.0510
2	3.142	.1632	2.835	.1473	1.656	.0852
2-1/2	4.909	.2550	4.602	.2390	2.503	.1301
3-1/4	8.296	.4309	7.511	.3902	5.154	.2700
4	12.566	.6528	11.781	.6120	7.658	.4010
5	19.635	1.020	18.850	.9792	10.014	.5210
6	28.274	1.468	26.789	1.392	15.708	.8201
8	50.266	2.611	48.781	2.534	26.507	1.380
10	78.540	4.080	76.135	3.956	54.780	2.850
12	113.10	5.918	109.96	5.712	89.337	4.640
14	153.94	7.997	149.04	7.309	130.178	6.760
16	201.06	10.444	196.16	10.190	178.302	9.260
18	254.47	13.219	244.85	12.715	230.709	11.980
20	314.16	16.320	301.60	15.667	291.400	15.140

TABLE B covers the smallest and the largest rod available per cylinder diameter. Intermediate rod end displacements can be calculated.

**TABLE C - CYLINDER PUSH AND PULL FORCES**

BORE	ROD	THEORETICAL FORCE IN POUNDS @ FLUID PRESSURE									
		100	250	300	500	800	1000	1200	1500	2250	2500
1-1/2	PUSH	176.7	441.8	530.1	883.5	1414	1767	2120	2650	3976	4418
	PULL — 5/8 ROD	146.0	365.0	438.0	730.0	1168	1460	1752	2190	3285	3650
	PULL — 1 ROD	98.0	245	294	490	783	980	1175	1470	2200	2450
2	PUSH	314.2	785.5	942.6	1571	2514	3142	3770	4713	7070	7855
	PULL — 5/8 ROD	283.5	708.7	850.5	1417	2268	2835	3402	4252	6379	7087
	PULL — 1-3/8 ROD	165.6	414	496.8	828	1324.8	1656	1987.2	2484	3726	4140
2-1/2	PUSH	490.9	1227	1473	2454	3927	4909	5891	7364		
	PULL — 5/8 ROD	460.2	1150	1381	2301	3682	4602	5522	6903		
	PULL — 1-3/4 ROD	250.3	625.8	751	1251	2002	2503	3004	3755		
3-1/4	PUSH	829.6	2074	2489	4148	6637	8296	9955	12444	18670	
	PULL — 1 ROD	751.1	1878	2253	3756	6009	7511	9013	11270	16900	
	PULL — 2 ROD	515.4	1288	1546	2577	4123	5154	6185	7731	11596	
4	PUSH	1257	3142	3770	6283	10050	12566	15079	18850		
	PULL — 1 ROD	1178	2945	3534	5890	9425	11781	14137	17671		
	PULL — 2-1/2 ROD	765.7	1914	2297	3828	6126	7657	9189	11486		
5	PUSH	1963	4908	5890	9817	15708	19635	23562			
	PULL — 1 ROD	1885	4712	5655	9425	15080	18850	22620			
	PULL — 3-1/2 ROD	1001	2503	3004	5006	8011	10013	12016			
6	PUSH	2827	7078	8482	14137	22619	28274	33928			
	PULL — 1-3/8 ROD	2679	6697	8037	13394	21431	26789	32147			
	PULL — 4 ROD	1570	3926	4712	7853	12566	15707	18850			
8	PUSH	5027	12566	15079	25133	40213	50266				
	PULL — 1-3/8 ROD	4878	12195	14634	24390	48781					
	PULL — 5-1/2 ROD	2650	6626	7952	13253	21205	26507				
10	PUSH	7854	19635	23562	39270	62832					
	PULL — 1-3/4 ROD	7614	19034	22840	38068	60908					
	PULL — 5-1/2 ROD	5478	13695	16434	27390	43825					
12	PUSH	11130	28275	33930	56550	90480					
	PULL — 2 ROD	10995	27486	32985	54975	87948					
	PULL — 5-1/2 ROD	8933	22334	26801	44670	71471					
14	PUSH	15394	38485	46182	76970	123152					
	PULL — 2-1/2 ROD	14900	37250	44700	74500	119232					
	PULL — 5-1/2 ROD	13018	32545	39054	65090	104152					
16	PUSH	20106	50265	60318	100530						
	PULL — 2-1/2 ROD	19616	49040	58480	98080						
	PULL — 5-1/2 ROD	17730	44325	53190	88650						
18	PUSH	25447	63617	76341	127235						
	PULL — 3-1/2 ROD	24485	61213	73445	122425						
	PULL — 5-1/2 ROD	23072	57680	69216	115360						
20	PUSH	31416	78640	94248	157080						
	PULL — 4 ROD	30160	75400	90480	150800						
	PULL — 5-1/2 ROD	29041	72603	87123	145205						

TABLE C covers the smallest and the largest rod available per cylinder diameter. Intermediate rod pull force can be calculated.

## INFORMATION TO PREVENT EXCESSIVE BEARING WEAR AND PISTON ROD COLUMN FAILURES

### GROUP A - WITH PISTON RODS EXTENDED

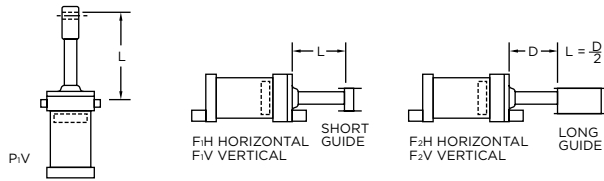

### GROUP B - TO BE CHECKED FOR BUCKLING OR JACK-KNIFING WITH PISTON RODS EXTENDED AND VERTICALLY MOUNTED

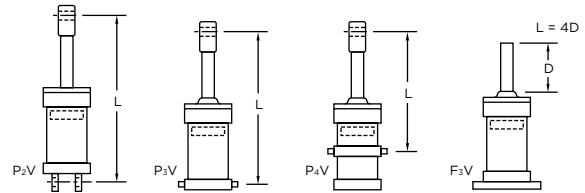

### GROUP C - TO BE CHECKED FOR LOAD ON BEARING WITH PISTON RODS EXTENDED AND HORIZONTALLY MOUNTED

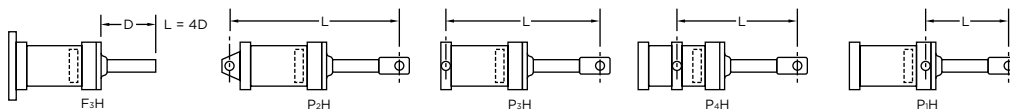

**STEP 1** — Find drawing in one of three groups above that fits your cylinder application and follow instructions listed for that group.

**Instructions:** Stop tubes are used on long push stroke cylinders to prevent jack-knifing or buckling. They are placed between the piston and cylinder head to restrict the extended position of the piston rod so that the lengthened space between piston and bushing provides additional piston rod guide support.

**The best choice for a cylinder with an exceptionally long stop tube requirement is the DOUBLE PISTON WITH SPACER. Note that the piston effective bearing area is doubled in addition to gaining the normal increased minimum distance between bearing points.**

To determine whether a stop tube is required on a push stroke cylinder, proceed as follows:

- Using above drawings, determine value of “L” from stroke length, rod and cylinder dimensions.
- Refer to TABLE A - Minimum and Maximum Stop Tube Lengths on page 141 for stop tube recommendation. A cylinder having an “L” value 45 requires a minimum of 1” stop tube and a maximum of 5” stop tube. Specifications for more than the maximum stop tube will usually adversely increase the cylinder weight.

**Example:** In a P<sub>2</sub>V type application requiring 32” of stroke, “L” = 32” + 32” + approximately 10” for head and cap thickness = 74”. A stop tube 4” long is required (when a fraction of an inch of stop tube is calculated, use the next full inch.) Adjusted value of “L” is 74” + 4” or 78”. Use of up to 8” of stop tube will further reduce bearing loads.

**Instructions:** Stop tubing is recommended for reducing piston and bushing/bearing loads on long stroke cylinders of the types shown. To determine length of stop tube required for this type of application, resolve the turning moments and loads between the piston and rod bushing. Include the weight of the fluid, especially on large bore cylinders. It is ideal to keep projected bearing area loads lower than 200 PSI.

**Caution:** Do not use oversize rods to lessen bearing loads. Stop tubes are more economical and effective; oversize rods are heavier, cost more than stop tubing and if misalignment occurs, bearing loads are considerably increased due to stiffness of the oversize rod.

If your drawing is F<sub>3</sub>H, P<sub>2</sub>H, P<sub>3</sub>H, or P<sub>4</sub>H, in Group C, check for stop tube requirements from instructions in Group B.

Use whichever stop tube is longer. Determine value of “L” and proceed to Step 2.

### STEP 2 — Find Rod Diameter for Column Strength.

Standard diameter piston rods are recommended on all installations except where column strength, piston rod sag, or return rate of hydraulic cylinders requires larger diameter rods.

Bushing/bearing loads caused by unavoidable misalignment are minimized when piston rods of correct diameter instead of unnecessarily large diameter piston rods are used. Correct (usually standard) piston rod diameters decrease and absorb shock loads to a greater extent than unnecessarily large oversize rods.

To determine the minimum piston rod diameter on push stroke cylinders:

- Determine your push stroke thrust from TABLE C - Cylinder Push and Pull Forces on page 139.
- Find your push stroke thrust “T” in TABLE B - Value of “L” In Inches on page 141. If exact thrust isn’t shown, use next larger shown.
- In the horizontal column in line with your thrust, find value of “L” determined in Step 1.
- Find minimum piston rod diameter required by following the same vertical line where your value of “L” is located, toward the top of the table.

**TABLE A - MINIMUM AND MAXIMUM STOP TUBE LENGTHS**

"L" INCHES	MINIMUM STOP TUBE LENGTH (INCHES)	MAXIMUM STOP TUBE LENGTH (INCHES)	"L" INCHES	MINIMUM STOP TUBE LENGTH (INCHES)	MAXIMUM STOP TUBE LENGTH (INCHES)	"L" INCHES	MINIMUM STOP TUBE LENGTH (INCHES)	MAXIMUM STOP TUBE LENGTH (INCHES)
5-10	-	1	111-120	8	12	211-220	18	22
11-20	-	2	121-130	9	13	221-230	19	23
21-30	-	3	131-140	10	14	231-240	20	24
31-40	-	4	141-150	11	15	241-250	21	25
41-50	1	5	151-160	12	16	251-260	22	26
51-60	2	6	161-170	13	17	261-270	23	27
61-70	3	7	171-180	14	18	271-280	24	28
71-80	4	8	181-190	15	19	281-290	25	29
81-90	5	9	191-200	16	20	291-300	26	30
91-100	6	10	201-210	17	21	301-310	27	31
101-110	7	11						

**NOTE:** Using stop tube lengths greater than "Maximum Stop Tube" has diminishing effect on reducing bearing loads.

**TABLE B - VALUE OF "L" IN INCHES**

AXIAL THRUST "T" AGAINST ROD END IN LBS. FORCE	MINIMUM PISTON ROD DIAMETER											
	0.63	1.00	1.38	1.75	2.00	2.50	3.00	3.50	4.00	4.50	5.00	5.50
50	67											
100	59	110										
150	53	103										
250	43	94										
400	37	83	134	186								
700	30	68	118	168	202	275						
1,000	27	60	105	155	190	257						
1,400	24	53	92	142	174	244	308	385				
1,800	23	48	82	127	160	230	294	366	440			
2,400	19	45	75	114	145	213	281	347	415	488		
3,200	16	41	67	103	130	194	262	329	400	461		
4,000	13	38	63	94	119	175	240	310	378	446		
5,000	9	34	60	87	110	163	225	289	360	426	494	
6,000		30	56	82	102	152	209	274	342	411	476	
8,000		26	50	76	93	137	186	245	310	375	447	
10,000		21	45	70	89	125	172	222	279	349	412	482
12,000		17	41	65	84	118	155	210	269	326	388	455
16,000			34	57	75	110	141	188	235	291	350	421
20,000			28	52	68	103	136	172	218	270	326	384
30,000				39	55	87	120	156	189	232	285	330
40,000				22	43	74	108	142	177	210	248	294
50,000					30	66	97	130	165	201	234	269
60,000						57	88	119	154	190	225	256
80,000						36	71	104	137	170	204	240
100,000							56	90	120	154	189	224
120,000							45	77	108	140	175	207
140,000								64	98	129	160	194
160,000								47	86	118	148	182
200,000									67	98	131	160
250,000										72	109	143
300,000											86	120
350,000											52	100
400,000												71

Values of "L" less than those shown have a slenderness ratio (length ÷ radius of gyration which is length ÷ 1/4 diameter of piston rod) of less than 50. Thus, the compressive strength formula ( $s = \text{thrust} \div \text{rod area}$ ) is used rather than the column strength formula on which Table B is based. For very low slenderness ratios (below 20), compressive strength formulae with a 2 to 1 factor of safety are satisfactory. For slenderness ratios between 20 and 50, use compressive strength formulae with proportionate factors between 2 to 1 and 5 to 1.

## EXPLODED VIEW

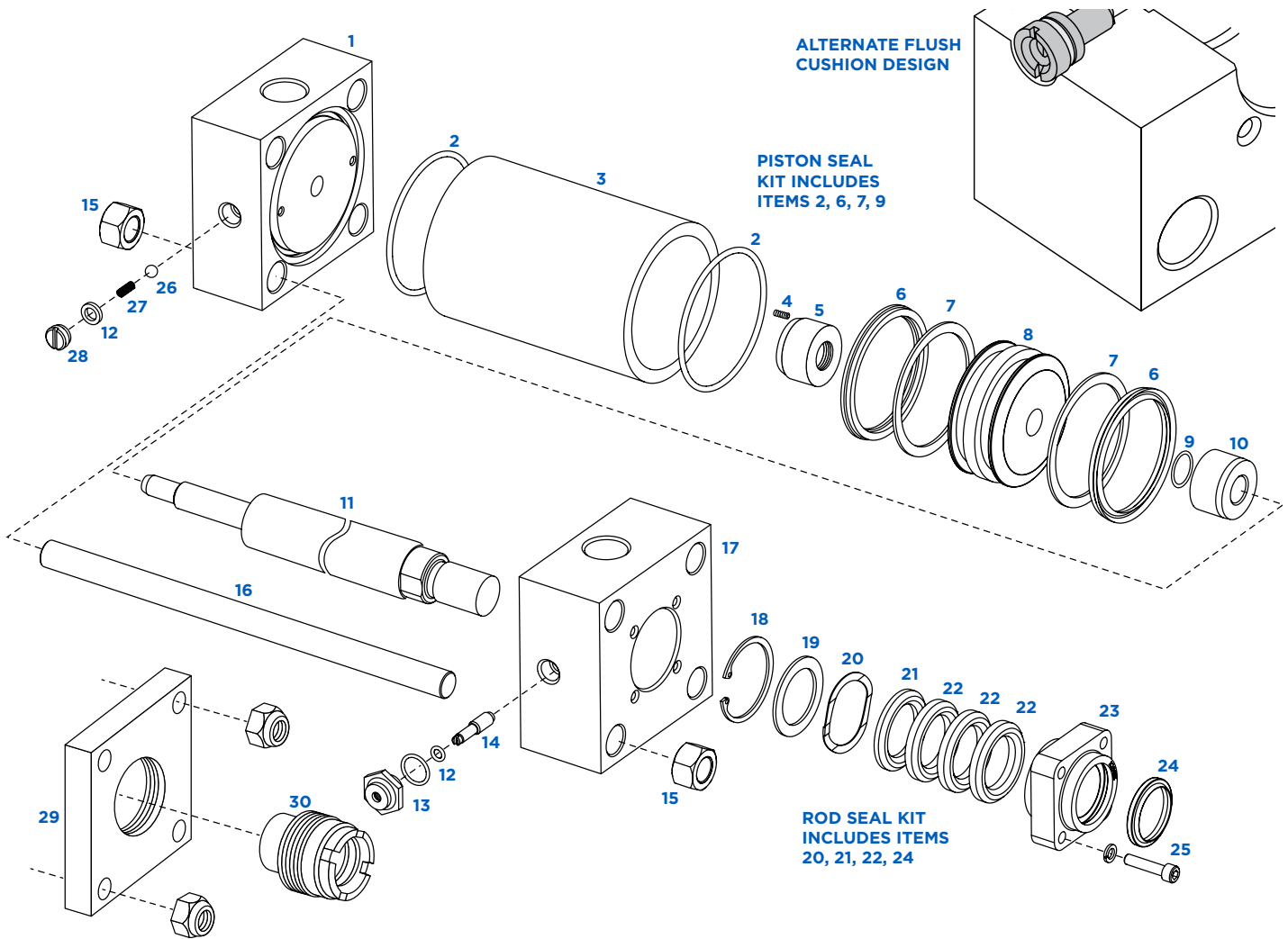

- |                                    |   |                                   |
|------------------------------------|---|-----------------------------------|
| <b>1</b> Blind end head            | <b>12</b> Seal                          | <b>23</b> Packing gland           |
| <b>2</b> Tube seal •               | <b>13</b> Cushion adjusting screw gland | <b>24</b> Rod wiper •             |
| <b>3</b> Tube                      | <b>14</b> Cushion adjusting screw       | <b>25</b> Packing gland cap screw |
| <b>4</b> Lock screw                | <b>15</b> Tie rod nut                   | <b>26</b> Check ball              |
| <b>5</b> Lock sleeve ▲             | <b>16</b> Tie rod                       | <b>27</b> Ball check spring       |
| <b>6</b> U-cup •                   | <b>17</b> Rod end head                  | <b>28</b> Ball check plug         |
| <b>7</b> Back-up ring •            | <b>18</b> Retainer ring                 | <b>IF APPLICABLE:</b>             |
| <b>8</b> Piston                    | <b>19</b> Packing spacer                | <b>29</b> Head plate              |
| <b>9</b> Piston O-ring •           | <b>20</b> Wave spring •                 | <b>30</b> Screw gland             |
| <b>10</b> Cushion sleeve - rod end | <b>21</b> Bottom adapter ring • ▪       |                                   |
| <b>11</b> Piston rod               | <b>22</b> Rod packing •                 |                                   |

• = Items are included in seal repair kits. See page 143 for ordering information.

▪ = Item 21 is metallic for high temp. applications. **NOTE:** Head and Screw Gland Option Available in all Models except DG (ME-3).

▲ = Use lock nut or threaded piston on 1.50"-8.00" bore with or without cushion, or cushion nose.

**When ordering replacement parts be sure to specify:**

- Part by name and item number
- Bore, stroke and mounting
- Serial number shown on NOPAK label

**NOTE:** Isometric view of DOUBLE ROD cylinders available at N/C. Consult factory or an authorized distributor.

## REPAIR KITS - CLASS P6 AND H6

FOR CURRENT DESIGN CYLINDERS MANUFACTURED AFTER MARCH 1982

### ROD KITS

SINGLE ROD*	
ROD DIA.	PART NO. ■
0.63"	RK6-63
1.00"	RK6-100
1.38"	RK6-138
1.75"	RK6-175
2.00"	RK6-200
2.50"	RK6-250
3.00"	RK6-300
3.50"	RK6-350
4.00"	RK6-400
4.50"	RK6-450
5.00"	RK6-500
5.50"	RK6-550

Each Rod Kit consists of:

- 1 - V-ring rod packing
- 1 - Rod wiper
- 1 - Wave spring

\* = To service DOUBLE ROD END CYLINDER, order one Rod Kit for EACH rod end, and if applicable, one Piston Kit.

### PISTON KITS

SINGLE OR DOUBLE ROD	
BORE SIZE	PART NO. ■
1.50"	PK6-150
2.00"	PK6-200
2.50"	PK6-250
3.25"	PK6-325
4.00"	PK6-400
5.00"	PK6-500
6.00"	PK6-600
8.00"	PK6-800
10.00"	PK6-1000
12.00"	PK6-1200
14.00"	PK6-1400

Each Piston Kit consists of:

- 2 - Tube O-rings
- 2 - Piston U-cups
- 2 - Back-up washers
- 1 - Piston O-ring

■ = When ordering, specify Type "A" or Type "B" seals.  
 Type "A" = Buna-N (NITRILE)  
 Type "B" = Fluorocarbon

## PACKING GLANDS - CLASS P6 AND H6

ROD DIA.	ALL MODELS EXCEPT D & DD ■	MODELS D & DD ONLY
	PART NUMBER	PART NUMBER
0.63"*	1069G70	1071G70
1.00"*	1068G73	2859G73
1.38"*	1066G75	2858G75
1.75"*	1067G77	2857G77
2.00"*	1065G78	2856G78
2.50"*	1064G79	2855G79
3.00"	1063G81	2854G81
3.50"*	1062G82	2853G82
4.00"*	1061G83	2852G83
4.50"	1060G84	2851G84
5.00"	1070G85	2850G85
5.50"	1059G86	C/F

- \* = Use packing gland 1071G70 for 1.50" cyl. with 0.63" Ø rod
- Use packing gland 2859G73 for 1.50" & 2.00" cyls. with 1.00" Ø rod
- Use packing gland 2858G75 for 2.00" cyl. with 1.38" Ø rod
- Use packing gland 2857G77 for 2.50" cyl. with 1.75" Ø rod
- Use packing gland 2856G78 for 3.25" cyl. with 2.00" Ø rod
- Use packing gland 2855G79 for 4.00" cyl. with 2.50" Ø rod
- Use packing gland 2853G82 for 5.00" cyl. with 3.50" Ø rod
- Use packing gland 2852G83 for 6.00" cyl. with 4.00" Ø rod

■ = For Models AL, T and TR, consult factory.





# Directional Control Valves

Hand, Foot and Solenoid

---

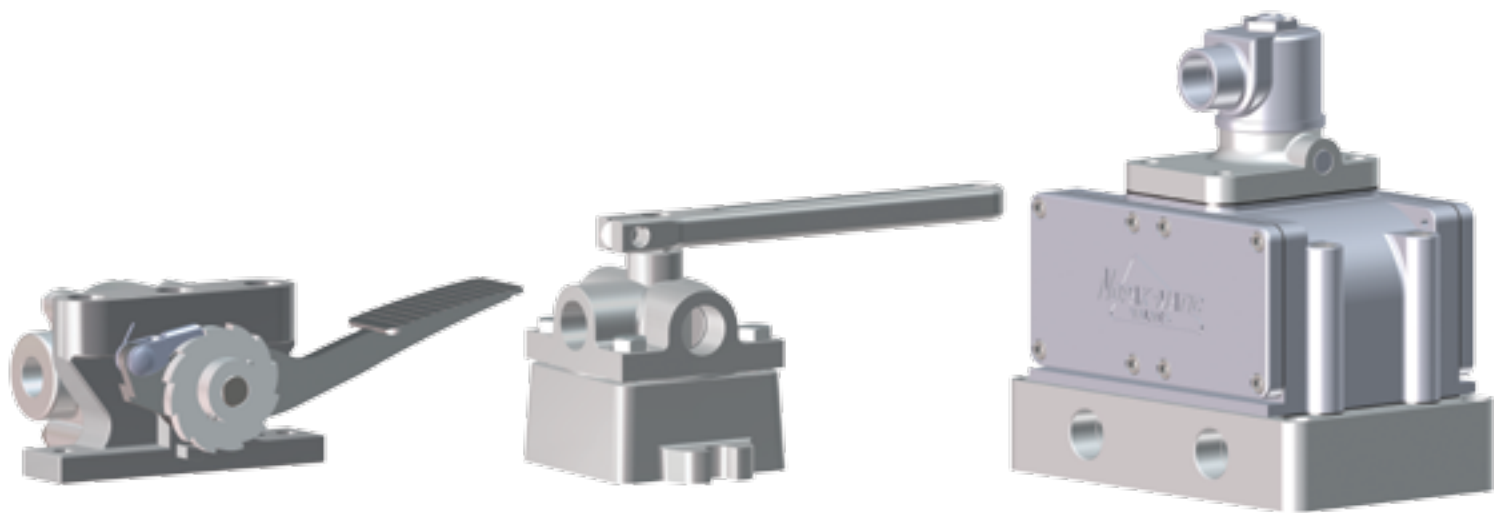

# NOPAK

First in Manufacturing. Engineered to Last.

## TABLE OF CONTENTS

<b>Hand &amp; Foot Valves</b> .....	<b>146</b>
Features and Benefits .....	147
How To Order .....	147
“Foundry Tough” Hand Valves – Disc Type .....	148
Foot Valves – Disc Type .....	152
Flotrol Valves .....	154
Parts List – NOPAK Disc Valves .....	154
Replacement Parts – NOPAK Disc Valves .....	154
Disc Valves .....	155
<b>Solenoid Valves</b> .....	<b>156</b>
Series 310, 320, 410 & 420 – Features and Benefits .....	156
Series 310PP & 410PP – Features and Benefits .....	157
How To Order .....	157
3-Way and 4-Way Valve Use .....	158
The Flow-Director .....	159
3-Way Series 300 .....	160
3-Way Series 310PP .....	161
3-Way Series 310 .....	162
3-Way Series 320 .....	163
4-Way Series 400 .....	164
4-Way Series 410PP .....	165
4-Way Series 410 .....	166
4-Way Series 420 .....	167
Disassembly .....	168
Make-Up Bleed .....	169
Direct Current Solenoids .....	170
C <sub>v</sub> Factors .....	171
Pressure Drop vs. Air Flow Graph .....	172

## NOPAK DIRECTIONAL CONTROL VALVES

NOPAK Directional Control Valves are noted throughout industry for their simplicity of design, rugged construction, long-lived, trouble-free service, and low maintenance. The original NOPAK Valve design, with its patented, rotating lapped disc, has been augmented with other designs until today the NOPAK line includes valves for control of fluid power under practically all operating conditions.

In specifying NOPAK Valves, operating requirements are the most important consideration. Such factors as unusual working conditions (heat, cold or moisture), the operating medium to be used (air, oil or water), line pressure and capacity, type of control (hand, foot, solenoid or pilot valve) – all must be considered in choosing the particular NOPAK Valve best suited for the application.

# FEATURES AND BENEFITS ORDERING INFORMATION

## FEATURES AND BENEFITS

NOPAK Disc-Type Valves have a well-earned reputation of being “practically indestructible.” They have established an enviable record for efficient, trouble-free operation, freedom from leakage and pressure loss, and long service life under extremely rugged operating conditions. These benefits are a direct result of the simplicity and ruggedness of the basic NOPAK Rotating Disc design. The flat, lapped disc, rotating at right angles to the stream flow, results in the following advantages:

### PRECISION CONTROL

Positive precision control through the complete cycle of valve operation, from slow gradual throttling action to instant full opening, without damaging shock, impact or pressure cutting.

### SEALING SURFACES IMPROVE WITH USE

The precision-lapped sealing surfaces of disc and seat actually improve with use because the “lapping-in” process continues while the valve is operated. The flat disc and seat have no interlocking contours; therefore, they cannot stick and always remain free for easy operation.

### PROTECTED AGAINST GRIT, ABRASION OR WIRE DRAWING

The valve seat is always covered by the rotating disc so that both sealing surfaces are always shielded from direct pressure flow and possible abrasion caused by grit, scale or other foreign matter usually present in air or hydraulic lines. An internal channel in the disc carries off such abrasive materials without damage to the sealing surfaces.

### PRESSURE SEALING

Line pressure is exerted against the valve disc at all times to keep the lapped surfaces of disc and seat positively sealed.

### PACKLESS CONSTRUCTION

NOPAK Valves depend entirely upon metal-to-metal, precision-lapped sealing surfaces for their leakproof construction. When used for hydraulic service (oil or water), additional protection against leakage past the valve stem has been provided by the use of an O-ring in the valve body and around the stem, just below the operating handle.

### ORDERING CODE EXAMPLE - HAND VALVES

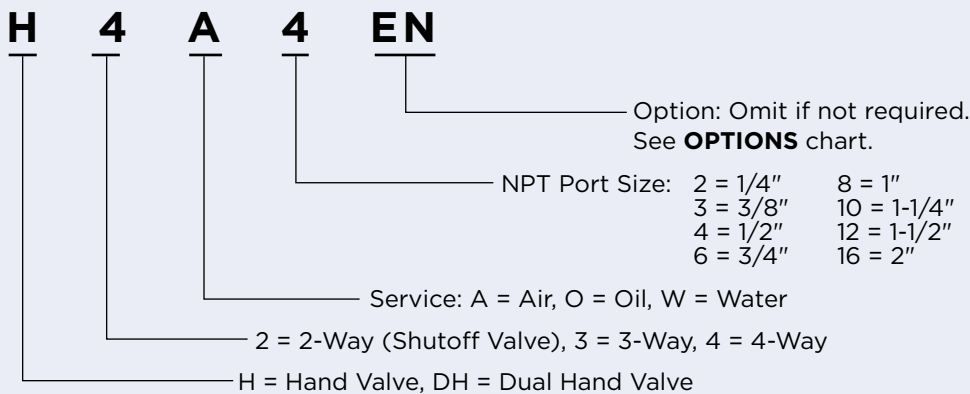

### OPTIONS

CODE	DESCRIPTION
EN	Exhaust In Neutral
SRN	Spring Return To Neutral
ST	Short Throw
STR	Short Throw & Spring Return
STNS	Short Throw No Spring
ENR	Exhaust In Neutral & Spring Return Neutral
B	Bleeder/Bleed Off
OC	Open Center
CC	Closed Center

### ORDERING CODE EXAMPLE - HAND VALVES, PANEL MOUNT

One size available: 1/4" NPT. See page 150.

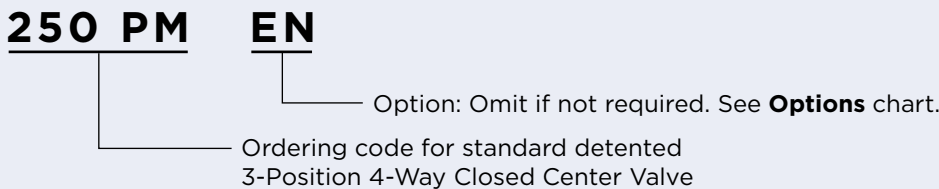

### ORDERING CODE EXAMPLE - FOOT VALVES

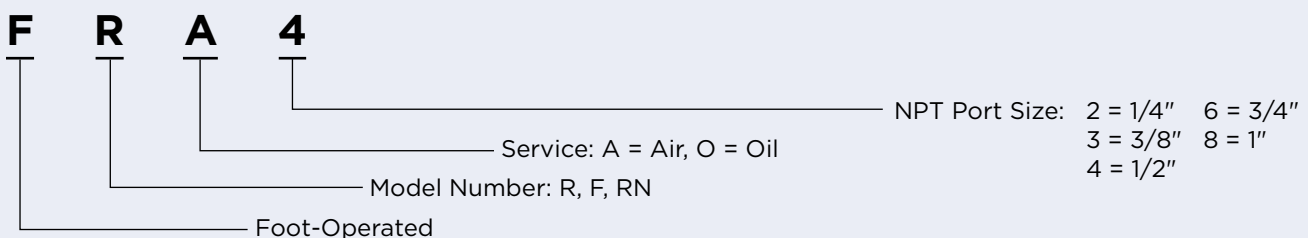

## 4-WAY, 3-POSITION AIR AND HYDRAULIC VALVES

The standard 4-way valve has two cycles of operation and is generally used to actuate double-acting cylinders. The construction and materials are identical to the 3-way valve. Both 3- and 4-way hand-operated air valves, 3/4" pipe size and larger, are fitted with grease cups to lubricate lapped surfaces.

### 4-Way, 2-Position, Short Throw

This valve has no neutral and is available with a total lever throw of 45° in the 1/4", 3/8", 1/2", 3/4" and 1" pipe sizes. It is available with a total lever throw of 60° in the 1-1/4", 1-1/2" and 2" pipe sizes. It is dimensionally identical with the standard 4-way valve and identified by "2/P" stamped on the spindle end.

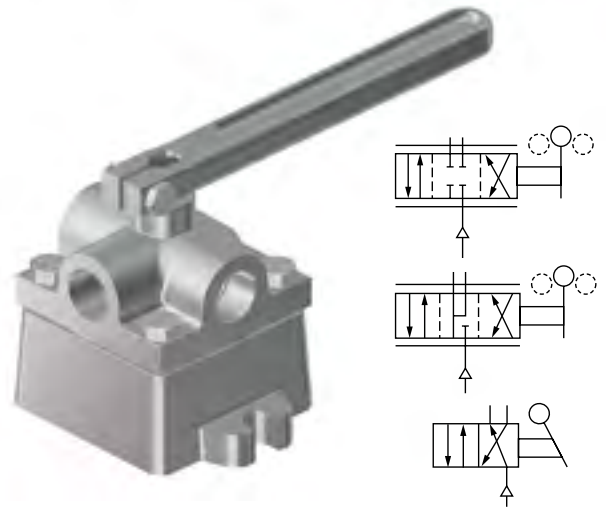

## 4-WAY SPRING RETURN TO NEUTRAL VALVES

Having the same basic construction and cycles of operation as the 4-way valves above, this valve is available in 1/4" through 1" pipe size for air, water and oil service at line pressures up to 100 PSI. Moving the lever to either extreme position pressurizes either cylinder port. A torsion spring located under the operating lever returns the lever to the neutral position when released. It is also available in the 2-position short throw valve.

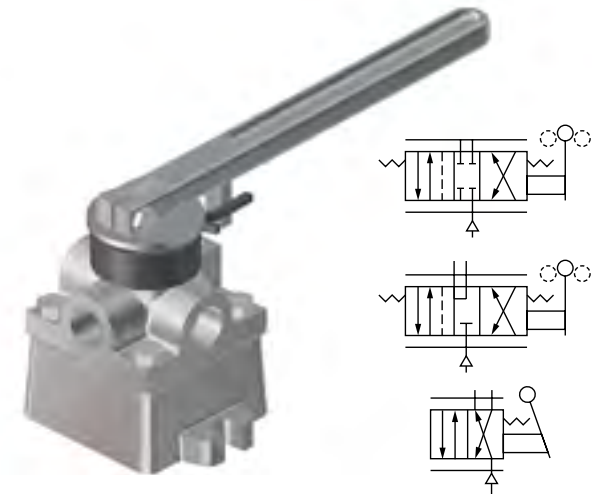

## 3-WAY AIR AND HYDRAULIC VALVES

The 3-way valve has two lever positions, pressure and exhaust, and is used to actuate single-acting cylinders.

The body and cap are made of semi-steel, the disc of hard bronze. This construction provides the best friction coefficient for air service and ensures easy operating and long wearing qualities.

These same materials are used for oil hydraulic service along with an O-ring in the body for extra precaution against stem leakage. For Water Service the valve body is constructed of cast bronze, uses a bronze spindle, a Nye-Koted cap, and the stem is equipped with an O-ring.

A 3-way, 3-position valve with a hold position can be had by using a standard 4-way valve and plugging one cylinder port.

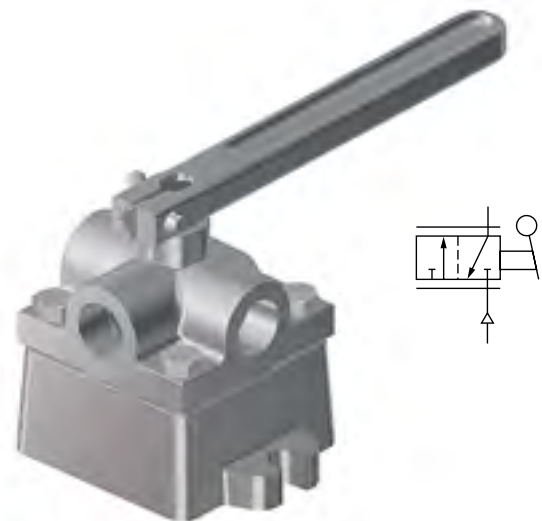

# “FOUNDRY TOUGH” HAND VALVES - DISC TYPE

## DATA AND DIMENSIONS

### 4-WAY VALVE, 250 PSI MAX. PRESSURE

MODEL NUMBER	A (PIPE SIZE)	B	C	D	E	F	G	H	K	WEIGHT IN POUNDS
H4( ) 2 ( )	1/4	1-7/8	3	2-1/2	2-1/2	2-3/4	4-1/4	5/16	1-3/16	2-1/4
H4( ) 3 ( )	3/8	2-1/4	3-7/8	2-7/8	3-1/16	3-3/4	6-1/8	7/16	1-9/16	4-3/4
H4( ) 4 ( )	1/2	2-1/4	3-7/8	2-7/8	3-1/16	3-3/4	6-1/8	7/16	1-9/16	4-3/4
H4( ) 6 ( )	3/4	2-3/4	4-7/8	3-7/8	4	4-5/8	8	9/16	1-15/16	6
H4( ) 8 ( )	1	3-1/2	5-5/8	4-1/4	4-1/4	5-3/8	9	9/16	2-1/2	16-7/8
H4( ) 10 ( )	1-1/4	5-1/4	7-13/16	6	6-7/16	6-3/4	12	9/16	3-3/4	29
H4( ) 12 ( )	1-1/2	5-1/4	7-13/16	6	6-7/16	6-3/4	12	9/16	3-3/4	29
H4( ) 16 ( )	2	6-7/16	9-3/4	7-1/4	7-7/16	8-3/8	15	13/16	4-1/2	49-1/4

NOTE: 1-1/4" and 1-1/2" valves have 3 mounting lugs on cap.

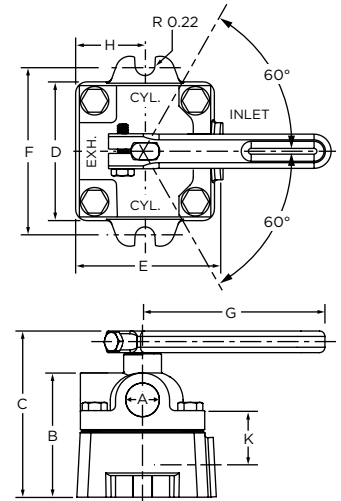

## DATA AND DIMENSIONS

### 4-WAY SPRING RETURN TO NEUTRAL VALVE, 100 PSI MAX. PRESSURE

MODEL NUMBER	A (PIPE SIZE)	B	C	D	E	F	G	H	K	WEIGHT IN POUNDS
H4( ) 2 ( )	1/4	1-7/8	3-5/8	2-1/2	2-1/2	2-3/4	5-1/2	5/16	1-3/16	2-3/4
H4( ) 3 ( )	3/8	2-1/4	4-5/8	3-1/8	3-1/4	3-3/4	8	7/16	1-3/4	6-5/8
H4( ) 4 ( )	1/2	2-1/4	4-5/8	3-1/8	3-1/4	3-3/4	8	7/16	1-3/4	6-5/8
H4( ) 6 ( )	3/4	2-3/4	4-7/8	3-7/8	4	4-5/8	8	9/16	1-13/16	7
H4( ) 8 ( )	1	3-1/2	6-3/8	4-1/4	4-9/16	5-3/8	9	9/16	2-1/2	16

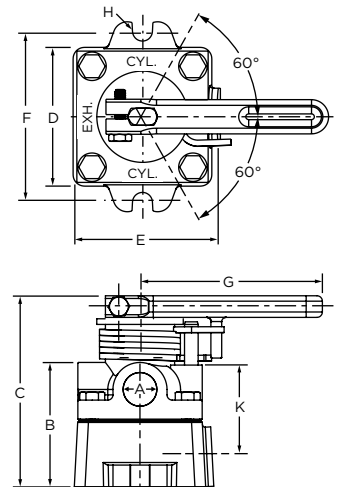

## DATA AND DIMENSIONS

### 3-WAY VALVE, 250 PSI MAX. PRESSURE

MODEL NUMBER	A (PIPE SIZE)	B	C	D	E	F	G	H	WEIGHT IN POUNDS
H3( ) 2 ( )	1/4	1-7/8	3	2-1/2	2-5/16	2-3/4	4-1/4	5/16	2
H3( ) 3 ( ) •	3/8	2-11/16	4-3/16	3-1/8	3-1/16	3-3/4	6	7/16	5-1/2
H3( ) 4 ( ) •	1/2	2-11/16	4-3/16	3-1/8	3-1/16	3-3/4	6	7/16	5-1/2
H3( ) 6 ( ) •	3/4	2-3/4	4-7/8	3-7/8	4	4-5/8	8	9/16	6
H3( ) 8 ( ) •	1	3-1/2	5-5/8	4-1/4	4-1/4	5-3/8	9	9/16	16-7/8
H3( ) 10 ( ) •	1-1/4	5-1/4	7-13/16	6	6-7/16	6-3/4	12	9/16	29
H3( ) 12 ( ) •	1-1/2	5-1/4	7-13/16	6	6-7/16	6-3/4	12	9/16	29
H3( ) 16 ( ) •	2	6-7/16	9-3/4	7-1/4	7-7/16	8-3/8	15	13/16	49-1/4

• = This valve is the 4-way of the same pipe size described in the table at the top of this page, with one cylinder port plugged.

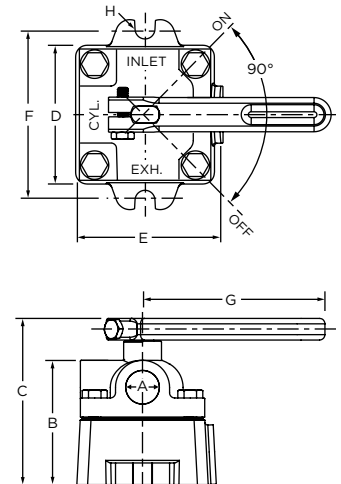

## NOPAK PANEL MOUNTED VALVE

The NOPAK Panel Mounted Valve, Model 250 PM, incorporates the same basic patented construction and sealing features of the reliable and rugged NOPAK Hand and Foot-Operated Valves, so well known throughout the industry for many years. The rotating lapped disc feature gives you precision control, sealing surfaces that improve with use, protection against grit, abrasion and wire drawing, pressure sealing, and packless construction.

The NOPAK Panel Mounted Valve is suitable for air and oil pressures to 250 PSI, and is presently offered in the 1/4" pipe size only. All-position detents are standard. An exhaust in neutral cycle is also available. The valve can also be furnished as 2-position short throw, which also includes detents as standard.

Panel mounting of the valve itself is easily accomplished by inserting the hand lever and pilot hub section through the panel and securing the valve by three cap screws. An optional detachable foot mounting plate is also available where panel mounting is not required or desired, NOPAK P/N 1097 NP.

TYPICAL  
INSTALLATION PLATE  
NOT INCLUDED WITH  
VALVE

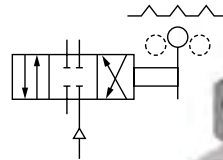
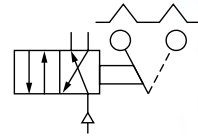
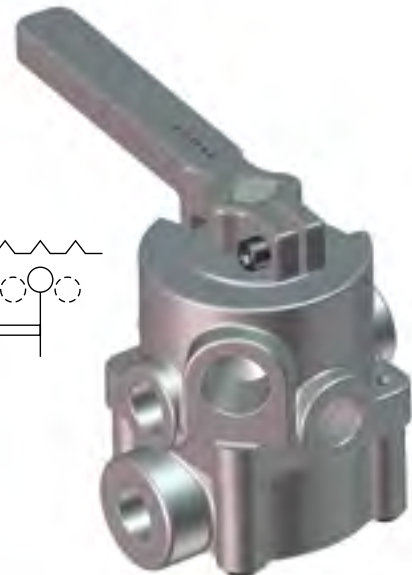
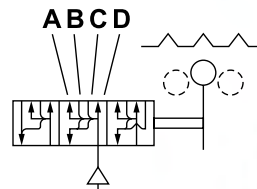

PLATE AVAILABLE AS  
OPTION P/N 1097 NP

## NOPAK DUAL 4-WAY HAND VALVE

This valve is the equivalent of two 4-way valves in one; it makes it possible to control the action of two double-acting cylinders with a single operating lever. Available in 1/2" size only.



# “FOUNDRY TOUGH” HAND VALVES - DISC TYPE

## DATA AND DIMENSIONS

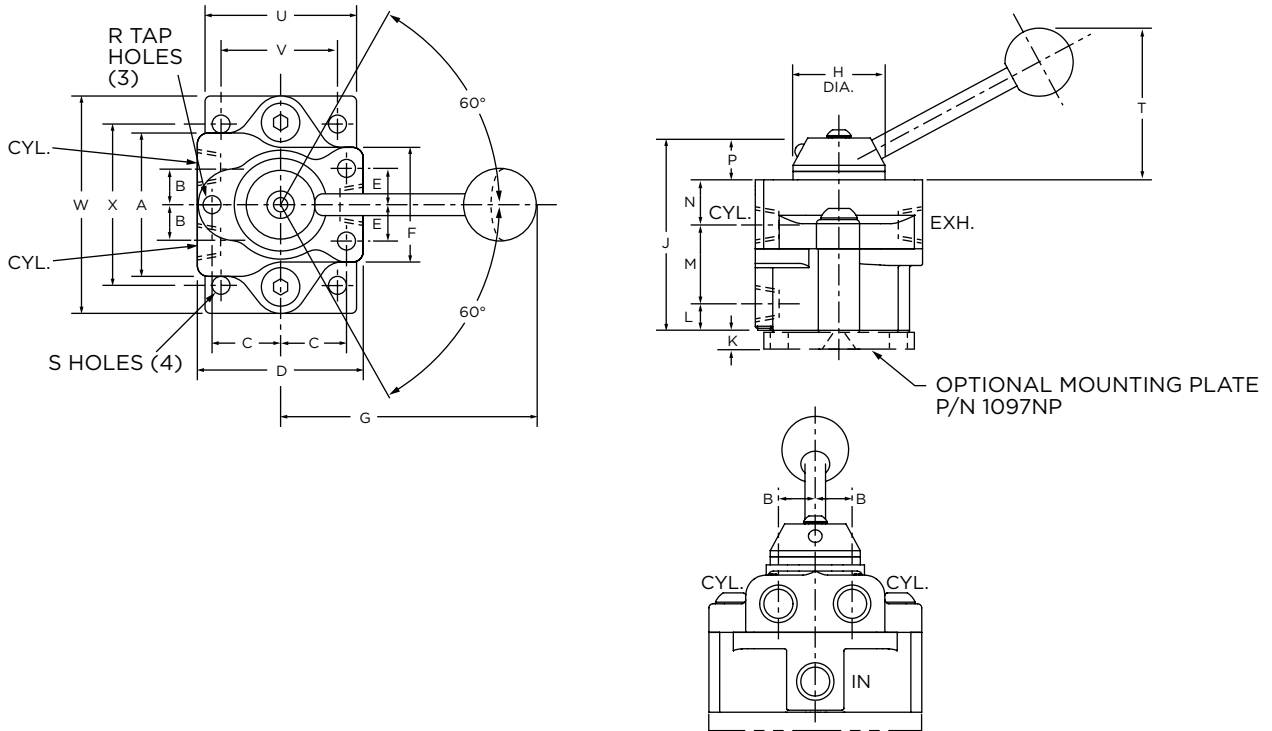

MODEL NUMBER	PIPE SIZE	A	B	C	D	E	F	G	H	J	K	L	M	N	P	R	S	T	U	V	W	X
250 PM ( )	1/4	2-1/8	9/16	1	2-1/2	1/2	1-3/4	3-7/8	1-3/8	2-15/16	1/4	1/2	1-3/16	5/8	1/8	1/4-20	9/32	2-1/2	2-1/4	1-3/4	3-1/4	2-1/2

## DATA AND DIMENSIONS

### DUAL 4-WAY VALVE, 250 PSI MAX. PRESSURE

MODEL NUMBER	PIPE SIZE	A	B	C	D	E	F	G	H	WEIGHT IN POUNDS
HD4( ) 4 ( )	1/2	4	2-1/4	2	7/8	2-9/16	3-7/16	5-3/8	6	8

### VALVE FUNCTION

LEVER POSITION	PRESSURE PORTS	EXHAUST PORTS
1	A-C	B-D
2	A-D	B-C
3	B-D	A-C

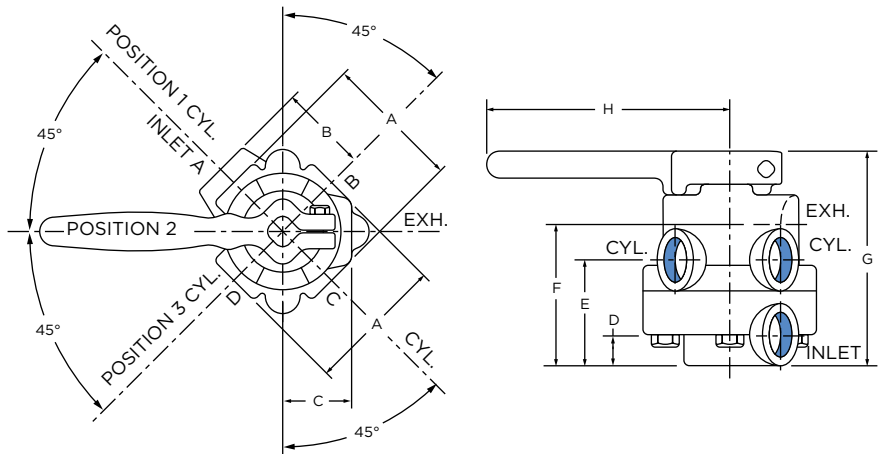

NPAK Foot-Operated Valves incorporate all the features found in the NPAK Hand-Operated models, including the lapped disc type design with the packless spindle construction.

In addition to the standard valves for air service, NPAK Foot-Operated Valves are available for oil service at additional cost.

## MODEL R

**MODEL R VALVE** has an oscillating disc with no neutral position. The valve spindle is pinned to the foot pedal. When pedal is up, the line pressure is always on Port No. 1 with Port No. 2 open to exhaust. When pedal is depressed 30°, cycle reverses, that is, line pressure is on Port No. 2 and Port No. 1 is open to exhaust. When pedal is released, the torque spring returns pedal to original position with pressure again on Port No. 1.

This valve can be used as a 3-way valve, for a single-acting cylinder, by inserting a pipe plug in one cylinder port. It can also be used as a spring-return shut-off valve, as follows: (a) Normally Closed by plugging Port No. 1 and exhaust; (b) Normally Open by plugging Port No. 2 and exhaust; (c) Bleeder arrangement for (a) or (b) is obtained by omitting plug in exhaust port.

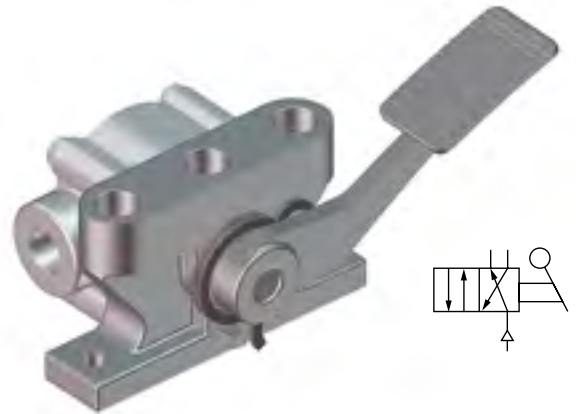

## MODEL F

**MODEL F VALVE** utilizes a pawl driven ratchet for rotation of the disc which has no neutral position.

The valve spindle is pinned to the ratchet. Let us assume that line pressure is on Port No. 1. Then, when foot pedal is depressed, the pawl, attached thereto, engages the ratchet and rotates it 30°, thereby reversing the valve cycle. When pedal is released, the torque spring returns pedal, but position of ratchet does not change. A second depression of pedal rotates ratchet a further 30°, again putting line pressure on Port No. 1. This model is particularly suited to applications in which the operator is required to leave the valve after depressing the foot pedal. This valve can also be used as a 3-way or shut-off valve, as described under Model R.

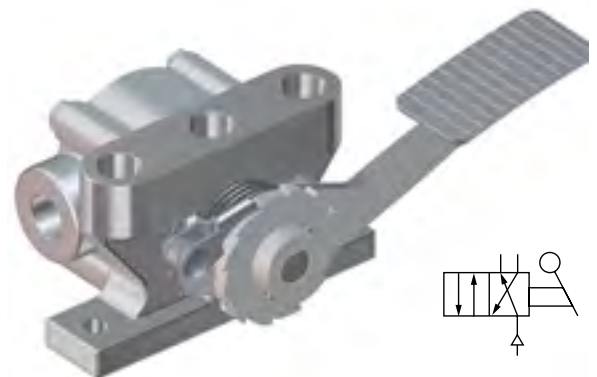

## MODEL RN

**MODEL RN VALVE** Double-Pedal, Foot-Operated, has a "NEUTRAL" or "SHUT-OFF" position in which both cylinder ports and exhaust ports are closed to pressure. It can be employed as an inching valve, its neutral holding position permitting an air cylinder to be positioned and held at any point along the full length of its stroke. This valve can also be furnished with cylinder ports open to exhaust in neutral position.

MODEL RN can also be furnished without spring-return to neutral, for either or both pedals. When spring-return is eliminated, the respective foot pedal rests in the "ON" position, holding the cylinder under pressure until operator steps on opposite pedal.

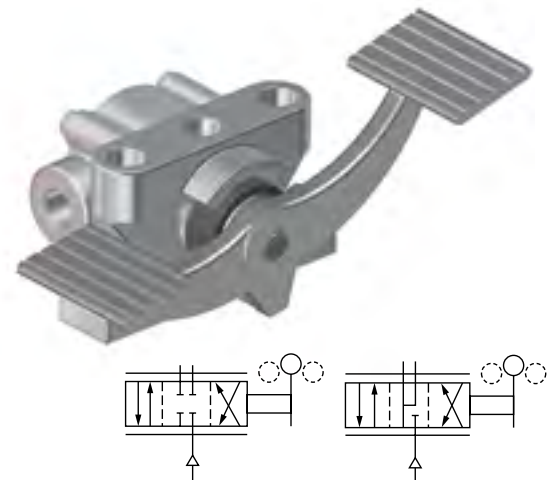



## DATA AND DIMENSIONS

### MODEL R VALVE, 125\* PSI MAX. PRESSURE

MODEL NUMBER	PIPE SIZE	B	C	D	E	F	G	H	J	K	WEIGHT IN POUNDS
FR( ) 2	1/4	5-1/16	2-9/16	1-11/16	3-9/16	1-13/16	6-1/2	2	1/2	7/16	10
FR( ) 3	3/8	5-1/16	2-9/16	1-11/16	3-9/16	1-13/16	6-1/2	2	1/2	7/16	10
FR( ) 4	1/2	5-1/16	2-9/16	1-11/16	3-9/16	1-13/16	6-1/2	2	1/2	7/16	10
FR( ) 6	3/4	5-7/8	3-1/4	1-15/16	4-5/16	2-5/16	6-1/2	2-1/4	5/8	9/16	14-5/8
FR( ) 8	1	5-7/8	3-1/4	1-15/16	4-5/16	2-5/16	6-1/2	2-1/4	5/8	9/16	14-5/8

\* Model R maximum pressure is limited by the returning power of the foot lever spring.  
1/4", 3/8" and 1/2" are available with foot pedal guard. Consult factory for additional information.

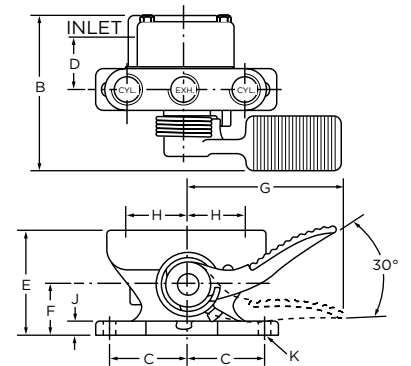

## DATA AND DIMENSIONS

### MODEL F VALVE, 250 PSI MAX. PRESSURE

MODEL NUMBER	PIPE SIZE	B	C	D	E	F	G	H	J	K	WEIGHT IN POUNDS
FF( ) 2	1/4	4-9/16	2-9/16	1-11/16	3-9/16	1-13/16	6-7/8	2	1/2	7/16	10
FF( ) 3	3/8	4-9/16	2-9/16	1-11/16	3-9/16	1-13/16	6-7/8	2	1/2	7/16	10
FF( ) 4	1/2	4-9/16	2-9/16	1-11/16	3-9/16	1-13/16	6-7/8	2	1/2	7/16	10
FF( ) 6	3/4	5-7/8	3-1/4	1-15/16	4-5/16	2-5/16	6-7/8	2-1/4	5/8	9/16	14-5/8
FF( ) 8	1	5-7/8	3-1/4	1-15/16	4-5/16	2-5/16	6-7/8	2-1/4	5/8	9/16	14-5/8

1/4", 3/8" and 1/2" are available with foot pedal guard. Consult factory for additional information.

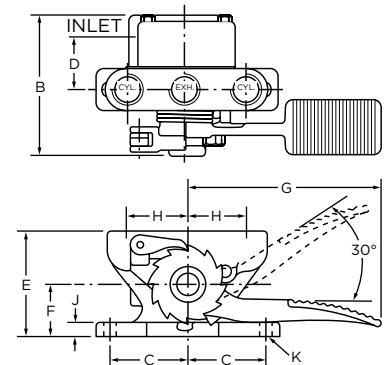

## DATA AND DIMENSIONS

### MODEL RN VALVE, 125\* PSI MAX. PRESSURE

MODEL NUMBER	PIPE SIZE	B	C	D	E	F	G	H	J	K	WEIGHT IN POUNDS
FRN( ) 2 ( )	1/4	6-9/16	2-9/16	1-11/16	3-9/16	1-13/16	5-5/8	2	1/2	7/16	11-3/4
FRN( ) 3 ( )	3/8	6-9/16	2-9/16	1-11/16	3-9/16	1-13/16	5-5/8	2	1/2	7/16	11-3/4
FRN( ) 4 ( )	1/2	6-9/16	2-9/16	1-11/16	3-9/16	1-13/16	5-5/8	2	1/2	7/16	11-3/4
FRN( ) 6 ( )	3/4	7-1/4	3-1/4	1-15/16	4-5/16	2-5/16	5-5/8	2-1/4	5/8	9/16	16-3/4
FRN( ) 8 ( )	3/4	7-1/4	3-1/4	1-15/16	4-5/16	2-5/16	5-5/8	2-1/4	5/8	9/16	16-3/4

\* This maximum pressure is limited by the returning power of the foot lever spring. Suitable for 250 PSI if returned by foot, not spring.

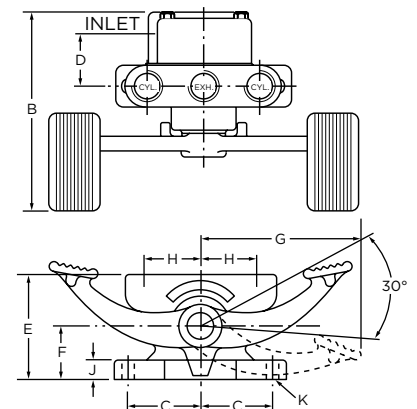

## NOPAK FLOTROL VALVES – AVAILABLE IN TWO BODY STYLES, FIVE PIPE SIZES

Features of the NOPAK Flotrol include full pipe area through the valve and a compact design that holds space requirements to a minimum and easy installation in the line. Valves are constructed of rust and corrosion resistant materials throughout and are adaptable to most industrial fluids.

Flotrol valves are available in two body styles that offer a total of five different pipe sizes ranging from 1/4" to 1" NPT. They are designed to handle pressures up to 2000 PSI in the 1/4", 3/8" and 1/2" sizes and to 300 PSI in the 3/4" and 1" sizes.

Bodies of the 1/4", 3/8" and 1/2" pipe sizes are machined from solid hexagon bronze bar stock. An aluminum body and bronze interior construction is used for the 3/4" and 1" models.

Control of the amount of flow going through the 1/4", 3/8" and 1/2" model Flotrols is regulated by a combination stainless steel needle valve and floating piston and spring assemblies. Flow through the 3/4" and 1" valves is adjusted by rotating a center floating sleeve – the sleeve acting as a union in the piping. Only 180° rotation is required from closed to full open.

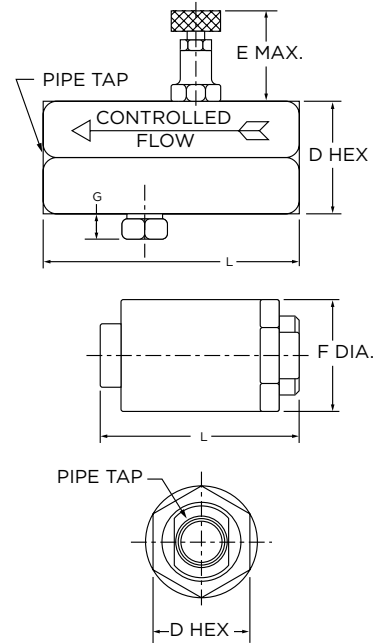

### DIMENSIONS

MODEL NUMBER	PIPE SIZES	D	E	F	G	L
SC-2	1/4	7/8	1-1/4	-	7/32	2-3/8
SC-3	3/8	1-1/16	1-3/8	-	1/4	2-3/4
SC-4	1/2	1-5/16	1-3/8	-	9/32	3-3/16
SC-6	3/4	2-3/16	-	2-1/2	-	4
SC-8	1	2-3/16	-	2-1/2	-	4

## PARTS LIST - NOPAK DISC VALVES

### HAND / FOOT / SPECIAL PURPOSE MODELS

1. Valve body
2. Valve cap
3. Valve disc
4. Valve spindle ] (one piece on some earlier models)
5. Disc spring
6. Lever (hand, foot, operating) complete
7. Body O-ring (hydraulic use only)
8. Spindle O-ring (hydraulic use only) – 3" size and up
9. Cap screws (not shown)

### SPRING RETURN MODELS

10. Return spring
11. Washer
12. Spring stop
13. Pin

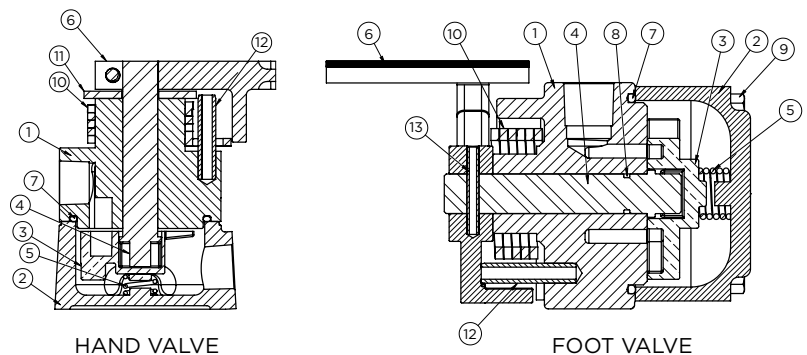

## REPLACEMENT PARTS – NOPAK DISC VALVES

When ordering replacement parts, please give the following information: Name of Part, Part Number, Dash No. (Pipe Size of valve), Type of Valve (full description: Manifold Valve, Spring Return Valve), and if possible, the Purchase Order Number on which the original valve was purchased. The valve body and valve disc should be replaced as a unit.



The disassembled components of a typical NOPAK Disc-type Valve. Note especially the simple rugged design, minimum number of parts.

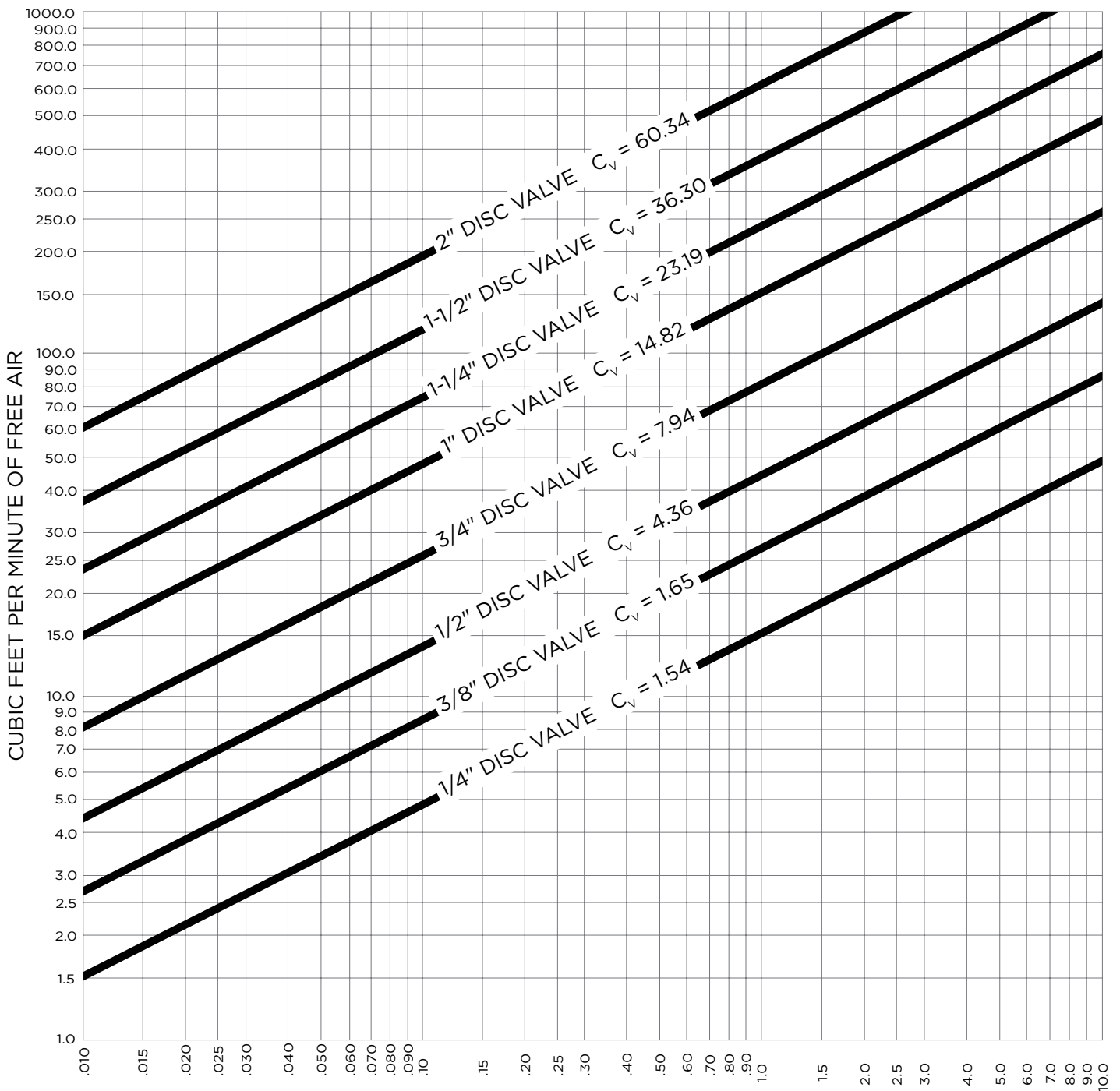

PRESSURE DROP IN PSI ( $\Delta P$ )

$P_s = 100$  PSIG

For other values of  $P_s$

$$\frac{10Q}{P_s} (\Delta P_{100}) = \Delta P_s$$

## SERIES 310, 320, 410 & 420

HIGH SPEED, HIGH VOLUME NOPAK-MATIC SINGLE AND DOUBLE SOLENOID VALVES

### FEATURES AND BENEFITS

**“FLOW-DIRECTOR” PILOT HEAD** – Simplifies piping and makes desired valve operation simple by piping to the proper port.

**INTERCHANGEABLE PILOT HEADS** – Any pilot head fits any valve, regardless of type or size.

**SOLENOIDS** – Low amperage, continuously rated industrial type with hardened plunger faces.

**REPLACEABLE, SELF-CLEANING SEATS** – Fast and inexpensive replacement of all seats. Poppets do not seat on valve body.

**POSITIVE SEALING** – Resilient, bonded poppet seals ensure leakproof operation and long life.

**RAPID RESPONSE** – Valve shifts in less than .05 of a second.

**FULL FLOW** – All passages oversized for minimum pressure drop through the valve (up to 1”).

**NO SPRINGS** – Piston-poppets shift with air pressure.

**LIGHT WEIGHT, COMPACT** – Aluminum used extensively for smaller overall dimensions. Every model has a clean, neat appearance that complements modern machine design. Base mounting is provided, but light weight of valves permits in-line mounting of largest valve.

**CORROSION RESISTANT** – All materials corrosion resistant.

**PART INTERCHANGEABILITY** – Design allows maximum part interchangeability from one valve to another and perfect “non-selected” fit of factory shipped maintenance parts.

**SIMPLIFIED PIPING** – Exclusive “Flow-Director” allows piping with fewer fittings...makes fewer valves adaptable to more applications. See page 159.

**MANIFOLD MOUNTING** – Multiple valves of the various series or sizes can be mounted on a common manifold requiring only one inlet and exhaust.

### ADDITIONAL FEATURES

- Subplate mounted
- Splash- and dust-proof solenoid covers
- Manual solenoid pushbuttons
- Covers chained to valve
- Solenoid inoperative with covers removed

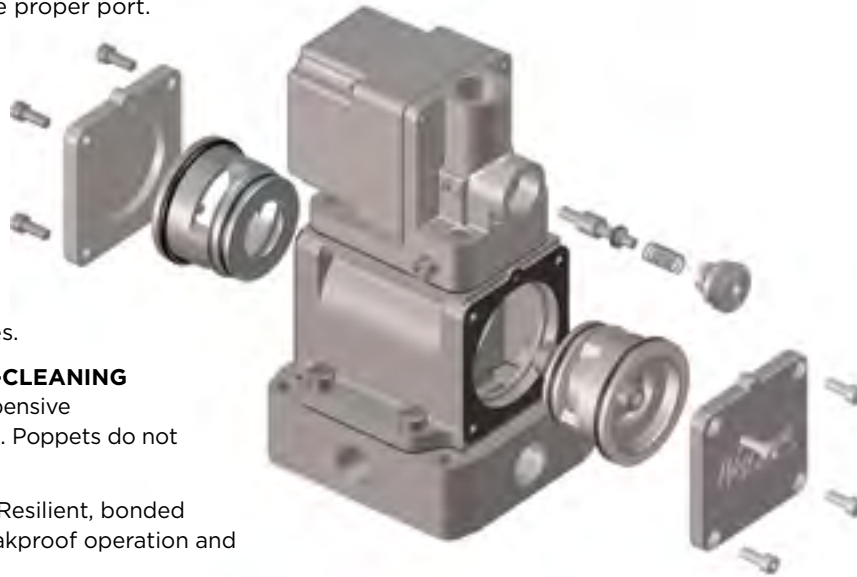
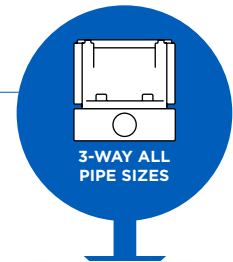

SERIES 300



SERIES 310PP



SERIES 310



SERIES 320

# FEATURES AND BENEFITS ORDERING INFORMATION

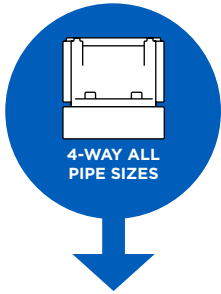

SERIES 400



SERIES 410PP



SERIES 410



SERIES 420

## SERIES 310PP & 410PP

COMPACT, RELIABLE NOPAK-MATIC SINGLE SOLENOID VALVES

### FEATURES AND BENEFITS

**ALL PURPOSE** - Developed especially as a compact, rugged, economically priced valve to solve the most demanding solenoid pilot operated air valve applications.

**FOR ALL ATMOSPHERIC CONDITIONS AND APPLICATIONS** - Simple pilot head operator is tolerant to dry, unlubricated air and dusty atmospheric conditions. Ideal for heavy-duty batching plant, construction, excavation and foundry applications.

**FAST ACTION** - Produces instantaneous valve response, even after long periods of solenoid energization or de-energization.

**MANUAL OVERRIDE** - Solenoid pilot available with manual override.

**Single Unit** - One pilot head fits all pipe size standard NOPAK-Matic master valves.

**LOW WATTAGE** - Efficient solenoid pilot rated at 10 operating watts in closed position.

**EXPLOSION PROOF** - As well as specially impregnated solenoid coils are available for hazardous, wet or high temperature environments.

**FAST MAINTENANCE** - Complete valve assembly can be replaced in less than 2 minutes, without disturbing piping.

**REPLACEABLE, SELF-CLEANING SEATS** - Fast and inexpensive to replace. Only two seat sizes required to fit all valves and are completely interchangeable within the valve or with other valves.

This valve is available with operating pressures to 125 PSI air in the 310PP and 410PP single-solenoid series only. In the case of the 4-way, when the solenoid is energized, pressure is admitted to one cylinder port, the opposite cylinder port being open to exhaust. When the solenoid is de-energized, the cycle is reversed.

**Seats Replaceable Without Disturbing Plumbing.**



## HOW TO ORDER

**WHEN ORDERING VALVES WITHOUT A SOLENOID, BE SURE TO SPECIFY:** (1) Model Number and (2) Pipe Size. Unless otherwise specified, all valves shipped are for standard air service. If the "make-up bleed" feature is required, it must be ordered as such.

**WHEN ORDERING VALVES WITH SOLENOID, BE SURE TO SPECIFY:** (1) Model Number, (2) Pipe Size and (3) Voltage and Cycle. Unless otherwise specified, all valves are shipped for standard air service, with 115V/60 solenoids.

**WHEN ORDERING VALVES FOR LOW PRESSURE (BELOW 15 PSI) OR VACUUM OPERATION, BE SURE TO SPECIFY:** Remote pilot supply and add suffix "M2" to the model number.

**WHEN ORDERING PARTS, BE SURE TO SPECIFY:** (1) Model Number, (2) Pipe Size, (3) Item Number, (4) Part Name, (5) Part Number and (6) Voltage and Cycle.

## USE 3-WAY NOPAK-MATIC VALVES:

- To control single-acting (spring-return) cylinders.
- To control double-acting cylinders:
  - Piping one 3-way valve at each end of the cylinder provides both quick exhaust and immediate pressure supply for extremely fast cylinder operation.
  - On long-stroke cylinders, using two 3-way valves eliminates filling and exhausting long lengths of pipe, thus reducing air consumption and increasing cylinder speed.
- To provide two pressure operation of a double-acting cylinder. Regulated pressure is directed to one end of cylinder through a 3-way valve, and line pressure to the other end of cylinder through the other 3-way valve.
- To provide directional control. Pressure can be piped to the outlet port and flow directed to either Port "A" or Port "B".

## USE 4-WAY NOPAK-MATIC VALVES:

- To obtain reciprocating action of double-acting cylinders.
- To operate long-stroke double-acting cylinders when maximum speed is not of prime importance.
- To obtain fast action and quick reversal of short-stroke cylinders.
- To provide control of low pressure and vacuum operation. Valve is modified by the addition of spring-loaded piston-poppet valve seat assemblies and may require remote pilot supply. (Also applicable to 3-Ways.) See Engineering Section.
- To control fluids other than air. In this case, fluid is piped into the valve body and pilot air pressure is brought to the pilot head from a remote source. See Engineering Section.

SERIES 300, 310PP, 310 AND 320 3-WAY VALVES FOR NORMALLY OPEN OR NORMALLY CLOSED OPERATION	MODEL AND PIPE SIZE						
	1/4	3/8	1/2*	1/2	3/4	1	1-1/4
Series 300 Master valves for remote control	300	301	301-1/2	302	303	304	305
Series 310PP Special purpose, single solenoid	310PP	311PP	311-1/2PP	312PP	313PP	314PP	315PP
Series 310 Single solenoid valves with spring-return pilot head	310	311	311-1/2	312	313	314	315
Series 320 Double solenoid valves (momentary contact-type)	320	321	321-1/2	322	323	324	325

\* = Models 301-1/2, 311-1/2 and 321-1/2 are 3/8" valves modified for 1/2" Ports.

SERIES 400, 410PP, 410 AND 420 4-WAY VALVES	MODEL AND PIPE SIZE						
	1/4	3/8	1/2*	1/2	3/4	1	1-1/4
Series 400 Master valves for remote control	400	401	401-1/2	402	403	404	405
Series 410PP Special purpose, single solenoid	410PP	411PP	411-1/2PP	412PP	413PP	414PP	415PP
Series 410 Single solenoid valves with spring-return pilot head	410	411	411-1/2	412	413	414	415
Series 420 Double solenoid valves (momentary contact-type)	420	421	421-1/2	422	423	424	425

\* = Models 401-1/2, 411-1/2 and 421-1/2 are 3/8" valves modified for 1/2" Ports.

## IN-LINE (ON-THE-JOB) MAINTENANCE

"In-line" maintenance is accomplished with small loss of production time. A NOPAK-Matic valve can be completely serviced in the line in less than fifteen minutes. The cover plates of the valve body, when removed, give immediate access to the piston-poppets and inserted valve seats. These parts are removable as complete assemblies. It is only a matter of minutes to completely replace all moving parts in the main valve. Damage to valve seats machined in the body can never be the cause of a NOPAK-Matic valve malfunctioning, for all valve seats are inserts and completely interchangeable.

## SUBPLATE MOUNTING

NOPAK-Matic makes use of subplate mounting of all valves. A complete valve assembly can be replaced in less than two minutes simply by loosening the four mounting screws that hold the valve body assembly to the subplate. Piping need never be disturbed.

Similarly, pilot heads are quickly replaceable as a unit simply by removing the four screws attaching it to the valve body.

Precision machining of all parts and maximum interchange of parts between valves of different types and sizes allow complete service of more than one hundred valve combinations with less than twenty-five individual parts. No waiting for special parts is required to get back in operation when you use NOPAK-Matic. A very small stock of parts is required for complete service of all sizes or types of NOPAK-Matic valves.

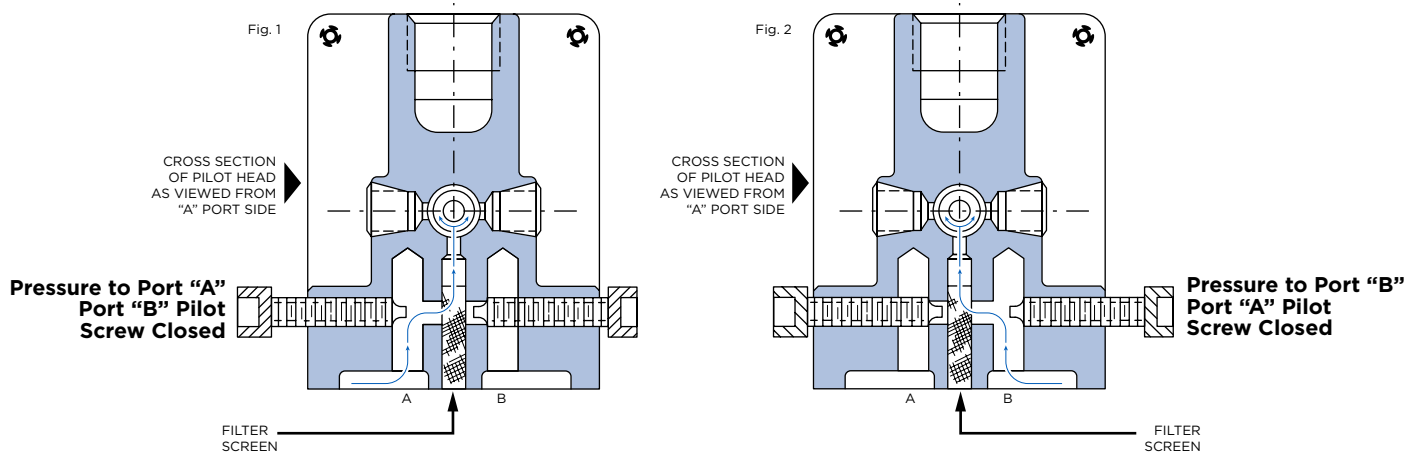

## THE FLOW-DIRECTOR

The Flow-Director®, exclusive with NOPAK-Matic™, gives you the choice of a Normally Closed or Normally Open 3-way valve, without time consuming and complicated reassembly of basic parts, and precludes the expense of buying special valves for each cycle. Also, in 4-way valves, crisscross piping can be eliminated.

The Flow-Director, using two manually set pilot screws, permits line pressure to be directed from the optional supply port to the pilot head.

### 4-WAY SERIES 410 OR 420 SOLENOID VALVES

Unless otherwise specified, all 4-way valves are assembled for pressure supply to Port "A" and pilot screws set as in Fig. 1. If line pressure supplied to Port "B" should result in more convenient piping, reverse position of pilot screws (see Fig. 2) as follows: BACK OUT THE PILOT SCREW ABOVE PORT "B" 6 COMPLETE TURNS, counter-clockwise. Then turn in clockwise, the opposite pilot screw, (above Port "A"),

until it solidly bottoms. Then FORCE IN 1/2 TURN MORE, to ensure tight seating.

### 3-WAY SERIES 310 OR 320 SOLENOID VALVES

Unless otherwise specified, all 3-way valves are assembled for NORMALLY CLOSED operation, with pilot screws set as in Fig. 1: supply to Port "A"; CYL. Port(s) closed to pressure and connected to Port "B" exhaust. For NORMALLY OPEN operation, reverse setting of pilot screws as shown in Fig. 2 and connect pressure supply to Port "B".

### PILOT HEAD FILTER SCREEN

All NOPAK-Matic pilot heads are equipped with a filter screen (see cross section above) to protect the pilot head seals. If screen collects an excessive amount of foreign matter, valve action may be slower than normal. If this occurs, remove and clean screen.

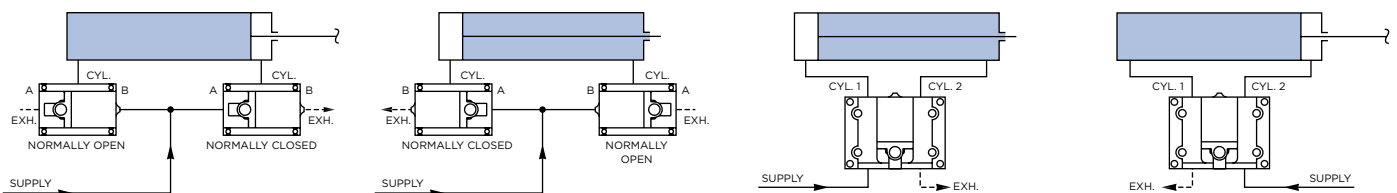

### 3-WAY NORMALLY OPEN OR NORMALLY CLOSED

Piping supply to Port "A" provides Normally Closed operation; supply to Port "B" provides Normally Open operation. Rotating the pilot head 180° (PP Models) or closing one Flow-Director needle or the other is all that's necessary to change operation. All 3-way valves have two cylinder outlet ports for further piping convenience.

The exclusive NOPAK-Matic Flow-Director pilot head selects pilot pressure from whichever port is used as inlet. It eliminates special valves for each application or reassembling parts. Addition of a pipe plug to any NOPAK-Matic 3-way valve converts it for 2-way operation. They can also be used for directional control.

### ELIMINATE CRISSCROSS PIPING

All NOPAK-Matic 4-way valves can be piped with pressure to Port "A" or Port "B". Flow through the valve is thus changed to meet the application requirements (rod extended or retracted). Crisscross piping to the cylinder is eliminated. Here again, the Flow-Director pilot head selects pilot pressure from the inlet port. There are no extensive changes to make in the valve...just reset the needles.

**MASTER VALVES**

**OPERATION**

**NORMALLY CLOSED OPERATION** — Supply connected to Port “A”, “CYL” Port closed to pressure, Port “B” exhaust.

**NORMALLY OPEN OPERATION** — Supply connected to Port “B”, “CYL” Port open to pressure, Port “A” exhaust.

**\*2-WAY OPERATION** — “For 2-Way Operation” must be so specified on the order as valve must be modified by insertion of poppet return spring in the master valve.

**PLUG EXHAUST PORT** — “B” for Normally Closed operation, “A” for Normally Open operation. Note that two cylinder ports are provided for simplification of piping. A sealing plug is provided for the unused port.

**PILOT PRESSURE** — Should equal or exceed pressure in valve body.

**ACTUATION** — Master valves can be actuated by any 3-way valve.

**OPTIONAL FEATURES**

- Series 300 valves can be modified for lower pressures, vacuum operation or service other than air. See Engineering Section.

**INSTALLATION DATA**

- Valves must have ADEQUATE SUPPLY (VOLUME) and UNRESTRICTED EXHAUST. Supply or exhaust lines should not be reduced more than one pipe size. Speed control valves or other restrictions can be placed in the cylinder supply lines.
- These valves can be operated Normally Open or Normally Closed to pressure simply by changing the piping. See OPERATION above.
- Valves will operate mounted in any position.



- Master Valves
- 2-Way\* and 3-Way
- Normally Open or Normally Closed
- 1/4", 3/8", 1/2", 3/4", 1", 1-1/4" Pipe Sizes
- Pressures 15 to 150 lbs Air

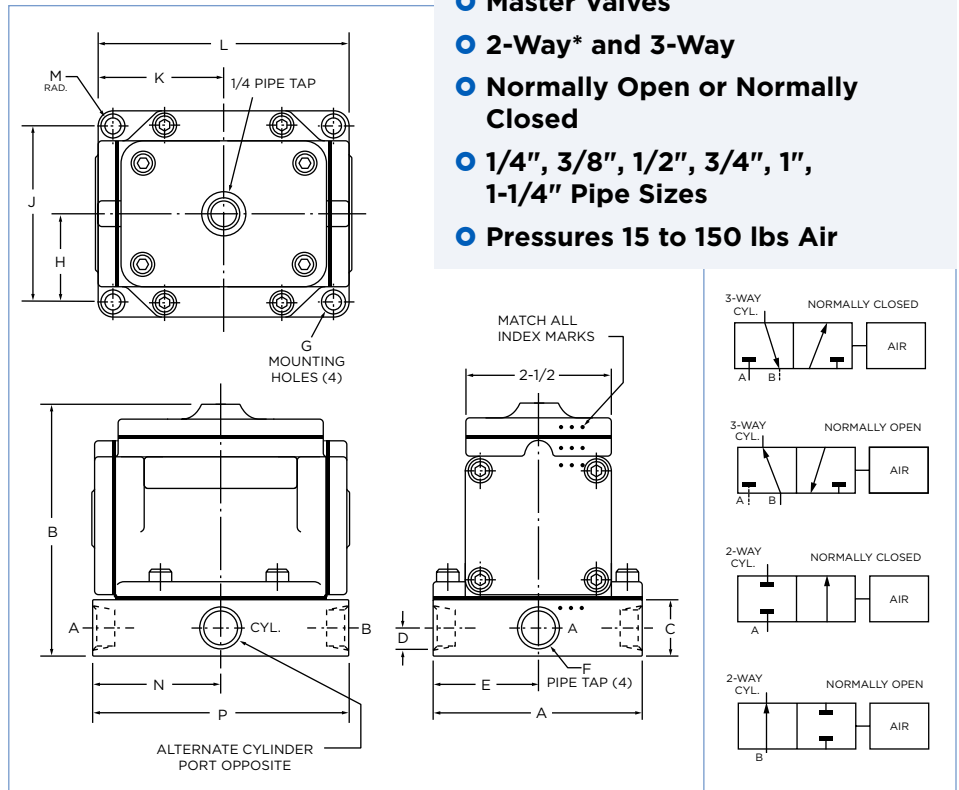

**Table 1** Dimension and Installation Data

SIZE	MODEL NUMBER	DIMENSIONS IN INCHES													
		A	B	C	D	E	F	G	H	J	K	L	M	N	P
1/4	300	3-9/16	4-1/2	1-1/8	9/16	1-25/32	1/4	17/64	1-17/32	3-1/16	1-29/32	3-13/16	1/4	2-5/32	4-5/16
3/8	301	3-9/16	4-1/2	1-1/8	9/16	1-25/32	3/8	17/64	1-17/32	3-1/16	1-29/32	3-13/16	1/4	2-5/32	4-5/16
1/2•	301-1/2	3-9/16	4-1/2	1-1/8	9/16	1-25/32	1/2	17/64	1-17/32	3-1/16	1-29/32	3-13/16	1/4	2-5/32	4-5/16
1/2	302	4	5-1/16	1-1/2	3/4	2	1/2	21/64	1-11/16	3-3/8	1-3/4	3-1/2	5/16	2-5/32	4-5/16
3/4	303	4	5-1/16	1-1/2	3/4	2	3/4	21/64	1-11/16	3-3/8	1-3/4	3-1/2	5/16	2-5/32	4-5/16
1	304	4-1/4	6-1/8	2-9/16	1-3/16	2-1/8	1	11/32	1-11/16	3-3/8	2-15/16	5-7/8	3/8	3-5/16	6-5/8
1-1/4	305	4-1/4	6-1/8	2-9/16	1-3/16	2-1/8	1-1/4	11/32	1-11/16	3-3/8	2-15/16	5-7/8	3/8	3-5/16	6-5/8

• = Model 301-1/2 is the standard 301 valve with 1/2" pipe taps.



## SPECIAL PURPOSE SINGLE SOLENOID VALVES

### FEATURES

Simple pilot head operator, tolerant to dry, unlubricated air and dusty environment. Ideal for heavy-duty batching plant, construction, excavating and foundry applications. Instantaneous valve response even after long periods of energization or de-energization. Solenoid pilot with manual override. Available for 115, 230, 460 volt A.C.; also D.C.

**\*2-WAY OPERATION** — “For 2-Way Operation” must be so specified on the order as valve must be modified by insertion of poppet return spring in the master valve.

### INSTALLATION DATA

- 310PP valves are assembled as standard for Normally Closed operation: supply to Port “A”, “CYL” Port blocked, Port “B” exhaust.
- Normally Open cycle can be obtained on the 310PP valves only by rotating the pilot head, but not the gasket, 180°. Inlet to Port “B”, “CYL” Port open, Port “A” to exhaust in energized position.

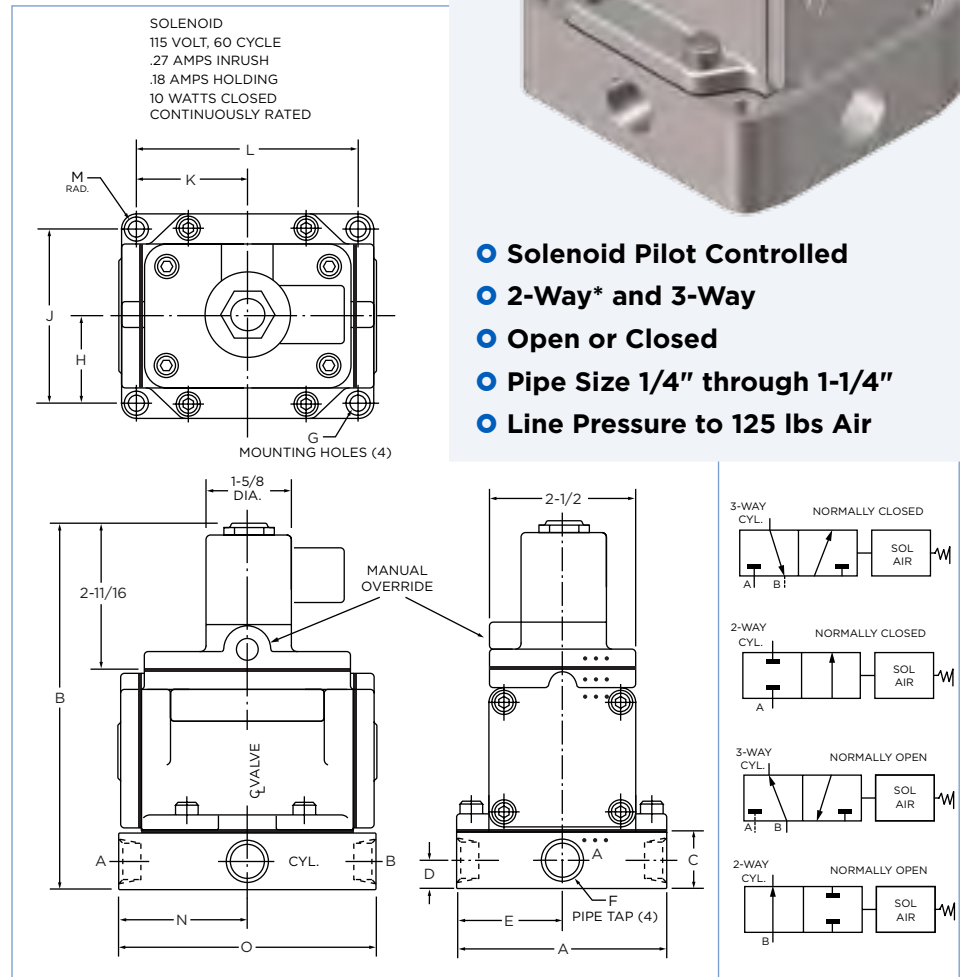

**Table 1** Dimension and Installation Data

SIZE	MODEL NUMBER	DIMENSIONS IN INCHES													
		A	B	C	D	E	F	G	H	J	K	L	M	N	O
1/4	310PP	3-9/16	6-5/8	1-1/8	9/16	1-25/32	1/4	17/64	1-17/32	3-1/16	1-29/32	3-13/16	1/4	2-5/32	4-5/16
3/8	311PP	3-9/16	6-5/8	1-1/8	9/16	1-25/32	3/8	17/64	1-17/32	3-1/16	1-29/32	3-13/16	1/4	2-5/32	4-5/16
1/2*	311-1/2PP	3-9/16	6-5/8	1-1/8	9/16	1-25/32	1/2	17/64	1-17/32	3-1/16	1-29/32	3-13/16	1/4	2-5/32	4-5/16
1/2	312PP	4	7-3/16	1-1/2	3/4	2	1/2	21/64	1-11/16	3-3/8	1-3/4	3-1/2	5/16	2-5/32	4-5/16
3/4	313PP	4	7-3/16	1-1/2	3/4	2	3/4	21/64	1-11/16	3-3/8	1-3/4	3-1/2	5/16	2-5/32	4-5/16
1	314PP	4-1/4	8-1/4	2-9/16	1-3/16	2-1/8	1	11/32	1-11/16	3-3/8	2-15/16	5-7/8	3/8	3-5/16	6-5/8
1-14	315PP	4-1/4	8-1/4	2-9/16	1-3/16	2-1/8	1-1/4	11/32	1-11/16	3-3/8	2-15/16	5-7/8	3/8	3-5/16	6-5/8

\* = Model 311-1/2PP is the standard 311PP valve with 1/2" pipe taps.

**SINGLE SOLENOID VALVES**

**OPERATION**

**NORMALLY CLOSED OPERATION** — Supply connected to Port “A”, “CYL” Port closed to pressure, Port “B” exhaust.

**NORMALLY OPEN OPERATION** — Supply connected to Port “B”, “CYL” Port open to pressure, Port “A” exhaust.

**\*2-WAY OPERATION** — “For 2-Way Operation” must be so specified on the order as valve must be modified by insertion of poppet return spring in the master valve.

**PLUG EXHAUST PORT** — “B” for Normally Closed operation, “A” for Normally Open operation. Note that two cylinder ports are provided for simplification of piping. A sealing plug is provided for the unused port. Also, on all valves with pilot heads, a remote supply must be provided to operate properly.

**OPTIONAL FEATURES**

- Indicator light: a neon pilot light can be provided to indicate the solenoid energizing.
- Solenoids for 115/50, 115/60, 230/50, 230/60, 460/50, 460/60, and 550/60 volt A.C. and 12, 16, 24, 32, 50, 90, 125, and 250 volt D.C. are in stock. Special coils, also heavy-duty and oil-immersed solenoids available on inquiry.
- Series 310 valves can be modified for lower pressures, vacuum operation or service other than air. See Engineering Section.

**INSTALLATION DATA**

- Valves must have ADEQUATE SUPPLY (VOLUME) and UNRESTRICTED EXHAUST. Supply or exhaust lines should not be reduced more than one pipe size. Speed control valves or other restrictions can be placed in the cylinder supply lines.
- Unless otherwise specified, Flow-Director in pilot head is set for Normally Closed operation. See OPERATION above. For Normally Open operation, setting must be reversed. - Flow-Director.
- If valve must be mounted with solenoid in a vertical position, then valve should be mounted so plunger and pilot stem climb when solenoid is energized. They are returned by spring and gravity.
- These valves should be operated with a remote pilot supply when used for service other than air, or for vacuum operation. See Engineering Section.



- Solenoid Pilot Controlled
- 2-Way\* and 3-Way
- Normally Open or Normally Closed
- 1/4", 3/8", 1/2", 3/4", 1", 1-1/4" Pipe Sizes
- Pressures 15 to 125 lbs Air

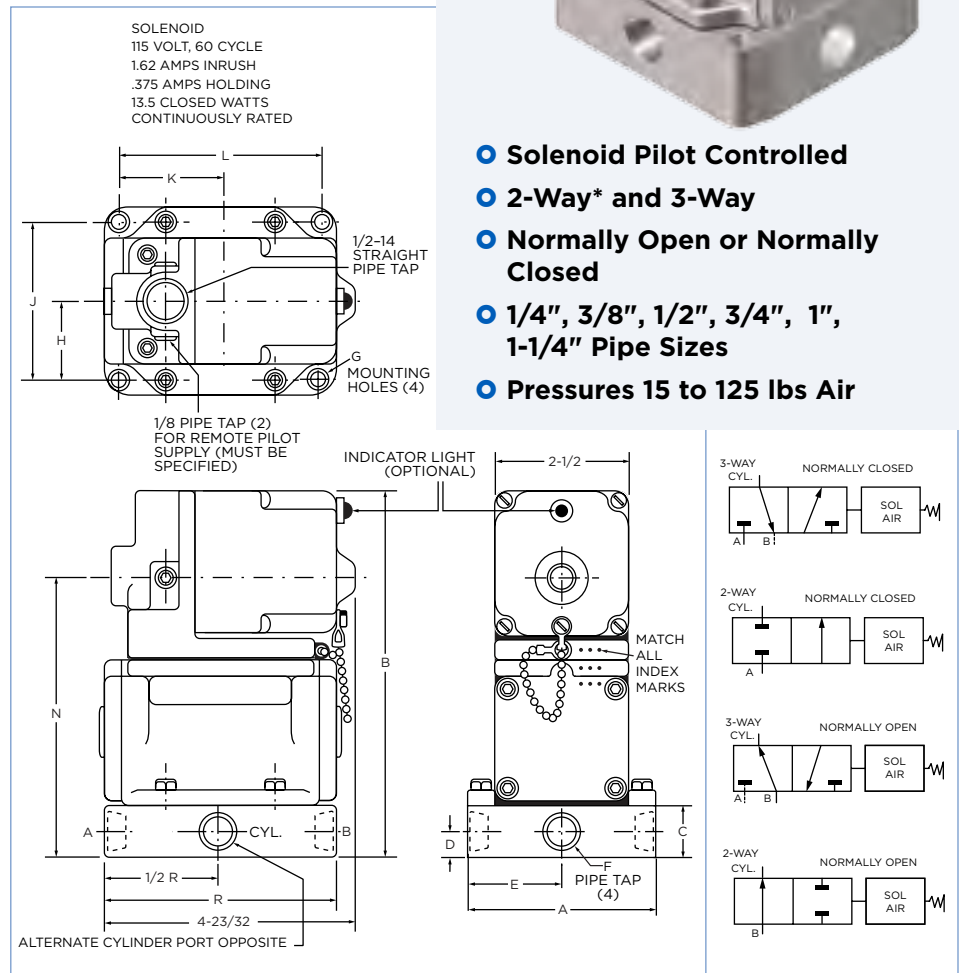

**Table 1** Dimension and Installation Data

D.C. solenoids are longer than A.C. shown here. See Engineering Section for D.C. dimensions.

SIZE	MODEL NUMBER	DIMENSIONS IN INCHES												
		A	B	C	D	E	F	G	H	J	K	L	N	R
1/4	310	3-9/16	7-1/4	1-1/8	9/16	1-25/32	1/4	17/64	1-17/32	3-1/16	1-29/32	3-13/16	5-1/2	4-5/16
3/8	311	3-9/16	7-1/4	1-1/8	9/16	1-25/32	3/8	17/64	1-17/32	3-1/16	1-29/32	3-13/16	5-1/2	4-5/16
1/2*	311-1/2	3-9/16	7-1/4	1-1/8	9/16	1-25/32	1/2	17/64	1-17/32	3-1/16	1-29/32	3-13/16	5-1/2	4-5/16
1/2	312	4	7-25/32	1-1/2	3/4	2	1/2	21/64	1-11/16	3-3/8	1-3/4	3-1/2	6-1/16	4-5/16
3/4	313	4	7-25/32	1-1/2	3/4	2	3/4	21/64	1-11/16	3-3/8	1-3/4	3-1/2	6-1/16	4-5/16
1	314	4-1/4	8-3/4	2-9/16	1-3/16	2-1/8	1	21/64	1-11/16	3-3/8	2-15/16	5-7/8	7-1/4	6-5/8
1-1/4	315	4-1/4	8-3/4	2-9/16	1-3/16	2-1/8	1-1/4	21/64	1-11/16	3-3/8	2-15/16	5-7/8	7-1/4	6-5/8

\* = Model 311-1/2 is the standard 311 valve with 1/2" pipe taps.

## DOUBLE SOLENOID VALVES

### OPERATION

**NORMALLY CLOSED OPERATION** — Supply connected to Port “A”, “CYL” Port closed to pressure, Port “B” exhaust.

**NORMALLY OPEN OPERATION** — Supply connected to Port “B”, “CYL” Port open to pressure, Port “A” exhaust.

**\*2-WAY OPERATION** — “For 2-Way Operation” must be so specified on the order as valve must be modified by insertion of poppet return spring in the master valve.

**PLUG EXHAUST PORT** — “B” for Normally Closed operation, “A” for Normally Open operation. Note that two cylinder ports are provided for simplification of piping. A sealing plug is provided for the unused port. Also, on all valves with pilot heads, a remote supply must be provided to operate properly.

### OPTIONAL FEATURES

- Indicator light: a neon pilot light can be provided to indicate the solenoid energizing.
- Solenoids for 115/50, 115/60, 230/50, 230/60, 460/50, 460/60, and 550/60 volt A.C. and 12, 16, 24, 32, 50, 90, 125, and 250 volt D.C. are in stock. Heavy-duty 115 volt 60 cycle and oil immersed 115 volt 60 cycle are also in stock. Special coils, also heavy-duty and oil immersed solenoids, available on inquiry.
- Series 320 valves can be modified for lower pressures, vacuum operation or service other than air. See Engineering Section.

### INSTALLATION DATA

- Valves must have ADEQUATE SUPPLY (VOLUME) and UNRESTRICTED EXHAUST. Supply or exhaust lines should not be reduced more than one pipe size. Speed control valves or other restrictions can be placed in the cylinder supply lines.
- Unless otherwise specified, Flow-Director in pilot head is set for Normally Closed operation. See OPERATION above. For Normally Open operation, setting must be reversed. See Engineering Section - Flow-Director.
- Valves will operate mounted in any position that results in the solenoids being placed in a horizontal position.
- These valves should be operated with a remote pilot supply when used for service other than air, or for vacuum operation. See Engineering Section.

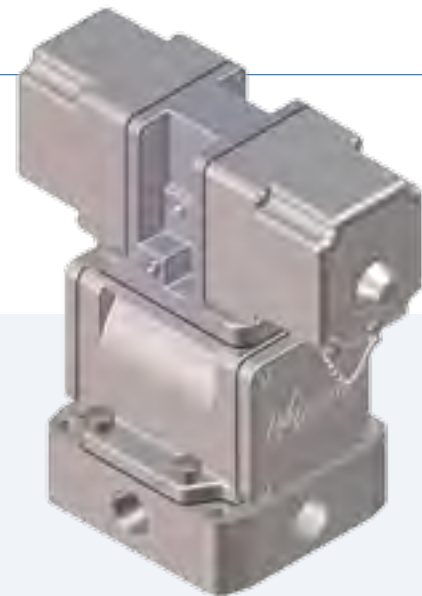
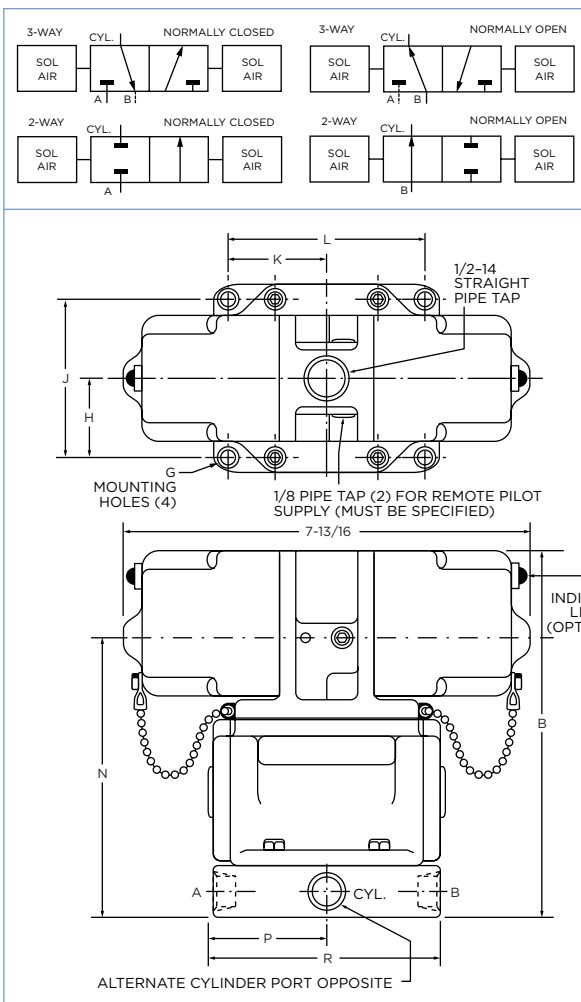

- Solenoid Pilot Controlled
- Momentary Contact Type
- 2-Way\* and 3-Way
- Normally Open or Normally Closed
- 1/4", 3/8", 1/2", 3/4", 1", 1-1/4" Pipe Sizes
- Pressures 15 to 150 lbs Air

## Table 1

Dimension and Installation Data

D.C. solenoids are longer than A.C. shown here. See Engineering Section for D.C. dimensions.

SIZE	MODEL NUMBER	DIMENSIONS IN INCHES													
		A	B	C	D	E	F	G	H	J	K	L	N	P	R
1/4	320	3-9/16	7-1/4	1-1/8	9/16	1-25/32	1/4	17/64	1-17/32	3-1/16	1-29/32	3-13/16	5-1/2	2-5/32	4-5/16
3/8	321	3-9/16	7-1/4	1-1/8	9/16	1-25/32	3/8	17/64	1-17/32	3-1/16	1-29/32	3-13/16	5-1/2	2-5/32	4-5/16
1/2	321-1/2	3-9/16	7-1/4	1-1/8	9/16	1-25/32	1/2	17/64	1-17/32	3-1/16	1-29/32	3-13/16	5-1/2	2-5/32	4-5/16
1/2	322	4	7-25/32	1-1/2	3/4	2	1/2	21/64	1-11/16	3-3/8	1-3/4	3-1/2	6-1/16	2-5/32	4-5/16
3/4	323	4	7-25/32	1-1/2	3/4	2	3/4	21/64	1-11/16	3-3/8	1-3/4	3-1/2	6-1/16	2-5/32	4-5/16
1	324	4-1/4	8-3/4	2-9/16	1-3/16	2-1/8	1	21/64	1-11/16	3-3/8	2-15/16	5-7/8	7-1/4	3-5/16	6-5/8
1-1/4	325	4-1/4	8-3/4	2-9/16	1-3/16	2-1/8	1-1/4	21/64	1-11/16	3-3/8	2-15/16	5-7/8	7-1/4	3-5/16	6-5/8

\* = Model 321-1/2 is the standard 321 valve with 1/2" pipe taps.

**MASTER VALVES**

**OPERATION**

**Port "A" INLET** — Supply connected to Port "A", "CYL 2" Port open to pressure, "CYL 1" Port open to exhaust through Port "B".

**Port "B" INLET** — Supply connected to Port "B", "CYL 1" Port open to pressure, "CYL 2" Port open to exhaust through Port "A".

**PILOT PRESSURE** — Should equal or exceed pressure in valve body.

**ACTUATION** — Master valves can be actuated by any 3-way valve.

**OPTIONAL FEATURES**

- Series 400 valves can be modified for lower pressures, vacuum operation or service other than air. See Engineering Section.

**INSTALLATION DATA**

- Valves must have ADEQUATE SUPPLY (VOLUME) and UNRESTRICTED EXHAUST. Supply or exhaust lines should not be reduced more than one pipe size. Speed control valves or other restrictions can be placed in the cylinder supply lines.
- These valves can be piped with either Port "A" or Port "B" as inlet. See OPERATION above.
- Valves will operate mounted in any position.



- Master Valves
- 4-Way
- 1/4", 3/8", 1/2", 3/4", 1", 1-1/4" Pipe Sizes
- Pressures 15 to 150 lbs Air

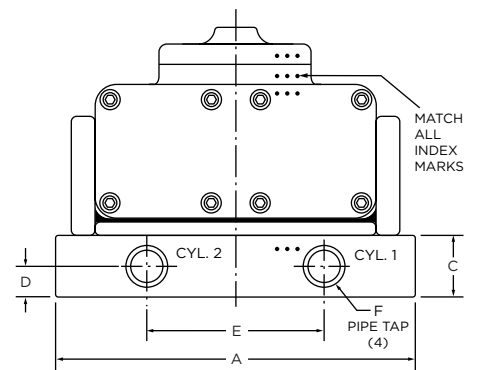
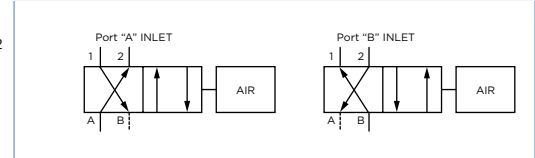
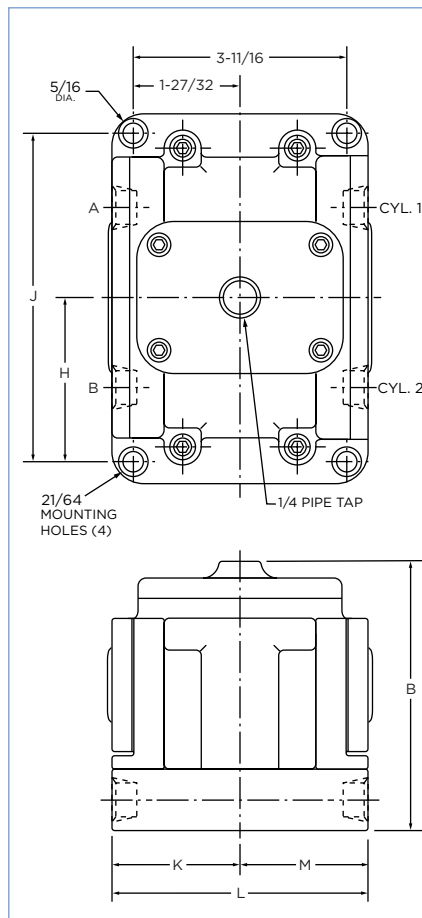

**Table 1** Dimension and Installation Data

SIZE	MODEL NUMBER	DIMENSIONS IN INCHES										
		A	B	C	D	E	F	H	J	K	L	M
1/4	400	6-1/8	4-11/16	1-1/8	1/2	2-9/16	1/4	2-3/4	5-1/2	2-5/32	4-5/16	2-5/32
3/8	401	6-1/8	4-11/16	1-1/8	1/2	2-9/16	3/8	2-3/4	5-1/2	2-5/32	4-5/16	2-5/32
1/2	401-1/2	6-1/8	4-11/16	1-1/8	1/2	2-9/16	1/2	2-3/4	5-1/2	2-5/32	4-5/16	2-5/32
1/2	402	7	5-13/16	1-7/16	3/4	3	1/2	3-3/16	6-3/8	2-5/32	4-5/16	2-5/32
3/4	403	7	5-13/16	1-7/16	3/4	3	3/4	3-3/16	6-3/8	2-5/32	4-5/16	2-5/32
1	404	7-1/4	6-7/8	2	1	2-15/16	1	3-3/16	6-3/8	2-27/32	5	2-5/32
1-1/4	405	7-1/4	6-7/8	2	1	2-15/16	1-1/4	3-3/16	6-3/8	2-27/32	5	2-5/32

\* = Model 401-1/2 is the standard 401 valve with 1/2" pipe taps.

## SPECIAL PURPOSE SINGLE SOLENOID VALVES

### FEATURES

Simple pilot head operator, tolerant to dry, unlubricated air and dusty environment. Ideal for heavy-duty batching plant, construction, excavating and foundry applications. Instantaneous valve response even after long periods of energization or de-energization. Pilot with manual override. Available for 115, 230, 460 volt A.C.; also D.C.

### INSTALLATION DATA

410PP valves are assembled as standard with Port "A" as pressure port. Energizing the solenoid pressurizes "CYL" Port 1 with "CYL" Port 2 open to exhaust. When the solenoid is de-energized, the cycle is reversed.



- Solenoid Pilot Controlled
- Maintained Contact Type
- 4-Way
- Pipe Sizes 1/4" through 1-1/4"
- Line Pressure to 125 PSI Air

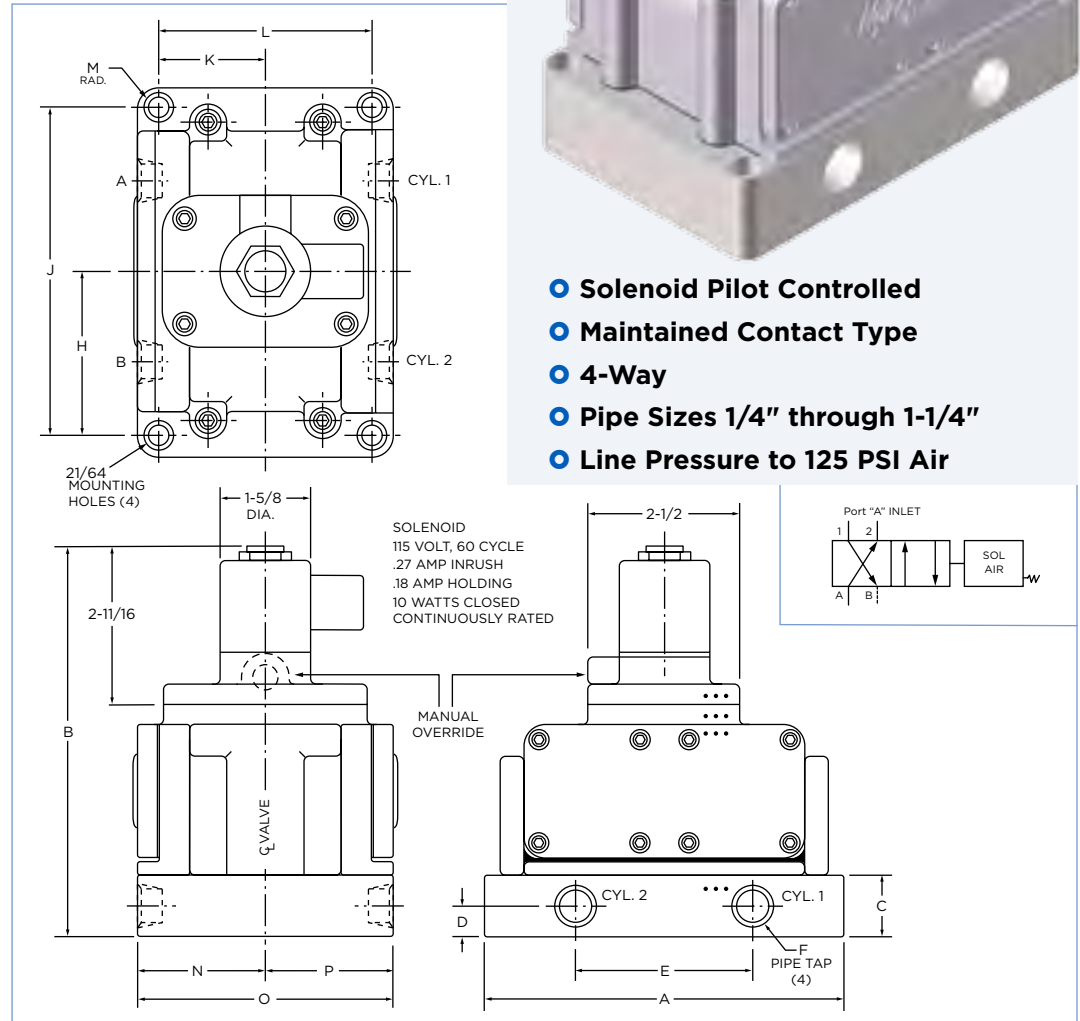

**Table 1** Dimension and Installation Data

SIZE	MODEL NUMBER	DIMENSIONS IN INCHES													
		A	B	C	D	E	F	H	J	K	L	M	N	O	P
1/4	410PP	6-1/8	6-13/16	1-1/8	1/2	2-9/16	1/4	2-3/4	5-1/2	1-27/32	3-11/16	1/4	2-5/32	4-5/16	2-5/32
3/8	411PP	6-1/8	6-13/16	1-1/8	1/2	2-9/16	3/8	2-3/4	5-1/2	1-27/32	3-11/16	1/4	2-5/32	4-5/16	2-5/32
1/2•	411-1/2PP	6-1/8	6-13/16	1-1/8	1/2	2-9/16	1/2	2-3/4	5-1/2	1-27/32	3-11/16	1/4	2-5/32	4-5/16	2-5/32
1/2	412PP	7	7-15/16	1-7/16	3/4	3	1/2	3-3/16	6-3/8	1-3/4	3-1/2	5/16	2-5/32	4-5/16	2-5/32
3/4	413PP	7	7-15/16	1-7/16	3/4	3	3/4	3-3/16	6-3/8	1-3/4	3-1/2	5/16	2-5/32	4-5/16	2-5/32
1	414PP	7-1/4	9	2	1	2-15/16	1	3-3/16	6-3/8	2-15/16	5-7/8	3/8	2-27/32	5	2-5/32
1-1/4	415PP	7-1/4	9	2	1	2-15/16	1-1/4	3-3/16	6-3/8	2-15/16	5-7/8	3/8	2-27/32	5	2-5/32

• = Model 411-1/22PP is the standard 411PP with 1/2" ports.

**SINGLE SOLENOID VALVES**

**OPERATION**

**Port "A" INLET** — Supply connected to Port "A", "CYL 2" Port open to pressure, "CYL 1" Port open to exhaust through Port "B".

**Port "B" INLET** — Supply connected to Port "B", "CYL 1" Port open to pressure, "CYL 2" Port open to exhaust through Port "A".

**OPTIONAL FEATURES**

- Indicator light: a neon pilot light can be provided to indicate the solenoid energizing.
- Solenoids for 115/50, 115/60, 230/50, 230/60, 460/50, 460/60, and 550/60 volt A.C. and 12, 16, 24, 32, 50, 90, 125, and 250 volt D.C. are in stock. Heavy-duty 115 volt 60 cycle and oil immersed 115 volt 60 cycle are also in stock. Special coils, also heavy-duty and oil immersed solenoids, available on inquiry.
- Series 410 valves can be modified for lower pressures, vacuum operation or service other than air. See Engineering Section.

**INSTALLATION DATA**

- Valves must have ADEQUATE SUPPLY (VOLUME) and UNRESTRICTED EXHAUST. Supply or exhaust lines should not be reduced more than one pipe size. Speed control valves or other restrictions can be placed in the cylinder supply lines.
- Unless otherwise specified, Flow-Director in pilot head is set for Port "A" inlet. See OPERATION above. For Port "B" inlet, setting must be reversed. See Engineering Section - Flow-Director.
- If valve must be mounted with solenoid in a vertical position, then valve should be mounted so plunger and pilot stem climb when solenoid is energized. They are returned by spring and gravity.
- These valves should be operated with a remote pilot supply when used for service other than air, or for vacuum operation. See Engineering Section.

- Solenoid Pilot Controlled
- Maintained Contact Type
- 4-Way
- 1/4", 3/8", 1/2", 3/4", 1", 1-1/4" Pipe Sizes
- Pressures 15 to 125 lbs Air

**Table 1** Dimension and Installation Data  
D.C. solenoids are longer than A.C. shown here. See Engineering Section for D.C. dimensions.

SIZE	MODEL NUMBER	DIMENSIONS IN INCHES											
		A	B	C	D	E	F	H	J	N	P	R	S
1/4	410	6-1/8	7-7/16	1-1/8	1/2	2-9/16	1/4	2-3/4	5-1/2	5-3/4	2-5/32	4-5/16	4-23/32
3/8	411	6-1/8	7-7/16	1-1/8	1/2	2-9/16	3/8	2-3/4	5-1/2	5-3/4	2-5/32	4-5/16	4-23/32
1/2*	411-1/2	6-1/8	7-7/16	1-1/8	1/2	2-9/16	1/2	2-3/4	5-1/2	5-3/4	2-5/32	4-5/16	4-23/32
1/2	412	7	7-15/16	1-7/16	3/4	3	1/2	3-3/16	6-3/8	6-1/4	2-5/32	4-5/16	4-23/32
3/4	413	7	7-15/16	1-7/16	3/4	3	3/4	3-3/16	6-3/8	6-1/4	2-5/32	4-5/16	4-23/32
1	414	7-1/4	8-7/16	2	1	2-15/16	1	3-3/16	6-3/8	6-3/4	2-11/16	5	5-9/32
1-1/4	415	7-1/4	8-7/16	2	1	2-15/16	1-1/4	3-3/16	6-3/8	6-3/4	2-11/16	5	5-9/32

\* = Model 411-1/2 is the standard 411 valve with 1/2" pipe taps.

## DOUBLE SOLENOID VALVES

### OPERATION

**Port "A" INLET** — Supply connected to Port "A", "CYL 2" Port open to pressure, "CYL 1" Port open to exhaust through Port "B".

**Port "B" INLET** — Supply connected to Port "B", "CYL 1" Port open to pressure, "CYL 2" Port open to exhaust through Port "A".

### OPTIONAL FEATURES

- Indicator light: a neon pilot light can be provided to indicate the solenoid energizing.
- Solenoids for 115/50, 115/60, 230/50, 230/60, 460/50, 460/60, and 550/60 volt A.C. and 12, 16, 24, 32, 50, 90, 125, and 250 volt D.C. are in stock. Heavy-duty 115 volt 60 cycle and oil immersed 115 volt 60 cycle are also in stock. Special coils, also heavy-duty and oil immersed solenoids, available on inquiry.
- 1" and 1-1/4" valves can be modified for lower pressures, vacuum operation or service other than air. See Engineering Section.

### INSTALLATION DATA

- Valves must have ADEQUATE SUPPLY (VOLUME) and UNRESTRICTED EXHAUST. Supply or exhaust lines should not be reduced more than one pipe size. Speed control valves or other restrictions can be placed in the cylinder supply lines.
- Unless otherwise specified, Flow-Director in pilot head is set for Port "A" inlet. See OPERATION above. For Port "B" inlet, setting must be reversed. See Engineering Section - Flow-Director.
- Valves will operate mounted in any position that results in the solenoids being placed in a horizontal position.
- These valves should be operated with a remote pilot supply when used for service other than air, or for vacuum operation. See Engineering Section.

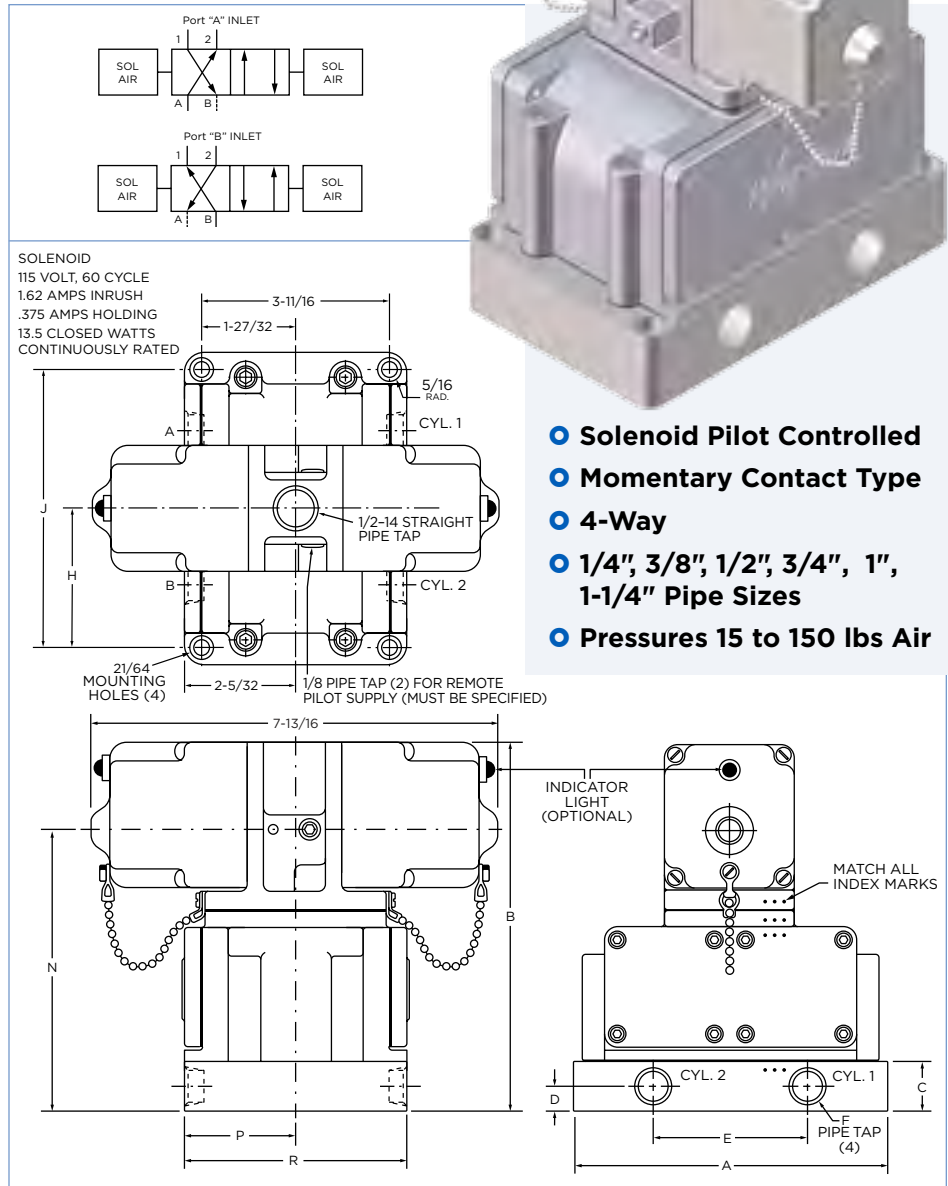
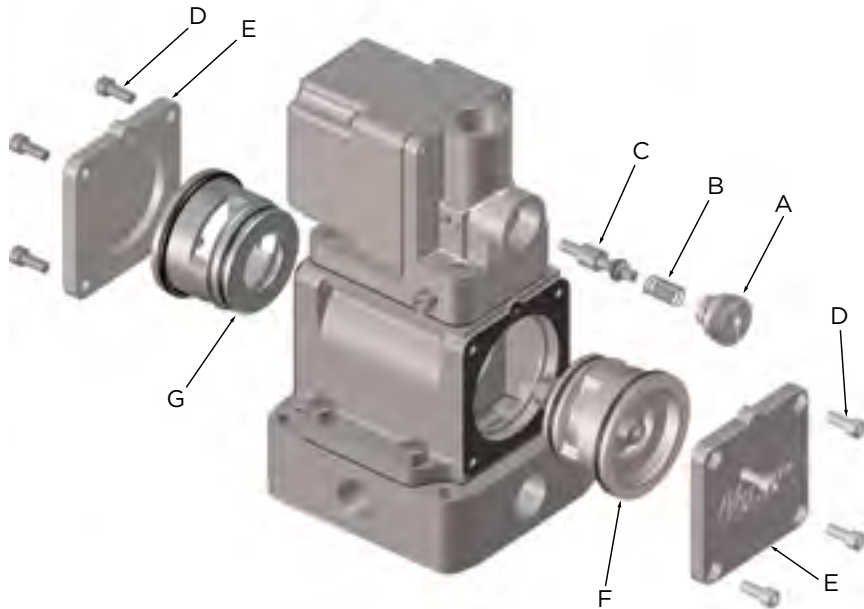

**Table 1** Dimension and Installation Data  
 D.C. solenoids are longer than A.C. shown here. See Engineering Section for D.C. dimensions.

SIZE	MODEL NUMBER	DIMENSIONS IN INCHES										
		A	B	C	D	E	F	H	J	N	P	R
1/4	420	6-1/8	7-7/16	1-1/8	1/2	2-9/16	1/4	2-3/4	5-1/2	5-3/4	2-5/32	4-5/16
3/8	421	6-1/8	7-7/16	1-1/8	1/2	2-9/16	3/8	2-3/4	5-1/2	5-3/4	2-5/32	4-5/16
1/2•	421-1/2	6-1/8	7-7/16	1-1/8	1/2	2-9/16	1/2	2-3/4	5-1/2	5-3/4	2-5/32	4-5/16
1/2	422	7	7-15/16	1-7/16	3/4	3	1/2	3-3/16	6-3/8	6-1/4	2-5/32	4-5/16
3/4	423	7	7-15/16	1-7/16	3/4	3	3/4	3-3/16	6-3/8	6-1/4	2-5/32	4-5/16
1	424	7-1/4	8-7/16	2	1	2-15/16	1	3-3/16	6-3/8	6-3/4	2-11/16	5
1-1/4	425	7-1/4	8-7/16	2	1	2-15/16	1-1/4	3-3/16	6-3/8	6-3/4	2-11/16	5

• = Model 421-1/2 is the standard 421 valve with 1/2" pipe taps.

**DISASSEMBLY**



**CAUTION!** Always shut off electrical and pressure supply and bleed all lines before any disassembly.

**REMOVAL OF PILOT STEM**

- 1 Unscrew pilot stem spring retainer nut A.
- 2 Remove spring B.
- 3 Push manual operating button. Then carefully pull out exposed pilot stem C.

**REMOVAL OF PISTON-POPPET ASSEMBLIES**

- 1 Remove socket head cap screws D on both sides of valve.
- 2 Drop valve body cover plates E.
- 3 Push out poppet assembly cartridge F by nudging with wooden dowel inserted through hole in valve seat cartridge G. Then push out cartridge G by inserting dowel into opening exposed by removal of cartridge F. (A wooden dowel should be used to prevent damage to sealing surfaces.)

**ASSEMBLY**

- 1 All parts should be carefully cleaned so that foreign particles are removed. Be sure to also check pilot head filter screen.
- 2 Moving parts must be lightly oiled with recommended lubricant; see list on page 170.
- 3 Damaged gaskets should be replaced.
- 4 Assemble parts in reverse order of disassembly.
- 5 Tighten all screws systematically to obtain an even pull-down. Do not over-tighten.

**REMOTE PILOT SUPPLY**

All NOPAK-Matic 2-, 3- and 4-way solenoid operated valves can be adapted for low pressure (below 15 PSI) vacuum service.

To accomplish this it is necessary to remotely supply the pilot section with at least 15 PSI air in order to shift the main poppets. Two special 1/8" NPT inlets are tapped into the pilot section, as shown below right, to bring the pilot air supply into either pilot inlet port. One inlet is sufficient, but two are supplied for convenience of piping. Unused port is plugged. Both pilot selector screws must be fully closed to ensure isolation of pilot section from master section of valve.

When using other media (oil for example), even at standard operating pressures, it is still necessary to bring air pressure to the pilot section, via the remote pilot supply feature. **Pilot pressure must meet or exceed main inlet pressure.** When ordering, please specify "Remote Pilot Supply." Also indicate:

- 1 Vacuum: specify maximum vacuum in HQ or equivalent. Special return spring will be furnished in piston-poppet assembly (see above).
- 2 Low pressure (below 15 PSI): special return spring furnished in piston-poppet assembly (see above).
- 3 Other media
  - A Type, description and specifications.
  - B Pressure.
  - C Temperature.
- 4 Voltage and cycle.

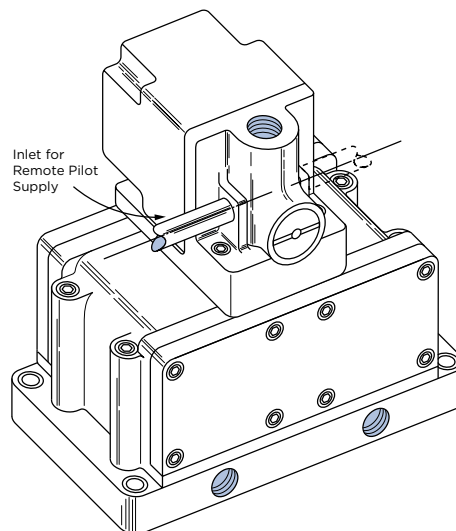



## MAKE-UP BLEED

NOPAK-Matic Master 3-Way or 4-Way Valves, supplied with a “make-up bleed” feature, eliminate the need of maintaining constant pilot pressure to hold the master valve in the energized position.

Normally, a 3-way valve is required to pilot the NOPAK-Matic master valve. With “make-up bleed,” two 2-way Normally Closed pilot valves can be used as follows: the first directs pressure into pilot head, the second exhausts pilot head to atmosphere.

As shown in the sketch to the right, a small orifice is drilled in the master valve body connecting the center chamber to the master valve head. When the valve is de-energized, the center chamber as well as the master valve head is exhausted.

A momentary actuation of the first 2-way pilot valve puts an impulse of air into the master valve head and moves the piston-poppet over to the energized position. This pressurizes the center chamber and make-up bleed continues to supply pressure to master valve head to compensate for any leakage through fittings, elbows, pipes, etc., after the first 2-way pilot valve has been closed. When the second 2-way pilot valve is momentarily actuated, air from the master valve head exhausts faster than the make-up bleed orifice can replenish the supply, resulting in the piston-poppet shifting back to the de-energized position.

Customer must specify “make-up bleed” when ordering this valve.

## NOPAK-MATIC VALVES FOR LOW PRESSURE OR VACUUM OPERATION

NOPAK-Matic valves can be adapted to low-pressure (below 15 PSI) or vacuum operation by the addition of a spring(s) in the piston-poppet seat assembly.

High pressure from the pilot head shifts the piston-poppet in one direction, spring pressure returns it to seat. Supply pressure from the pilot head must be 15 PSI or more.

When ordering, specify modification desired: “M2 Low Pressure” or “M2 Vacuum”.

See bottom of page 168 for remote pilot supply operation.

- ENGINEERING**
- **Make-Up Bleed**
- **Spring Loaded Piston-Poppet**
- **Flow-Director**
- **Proper Lubricants**

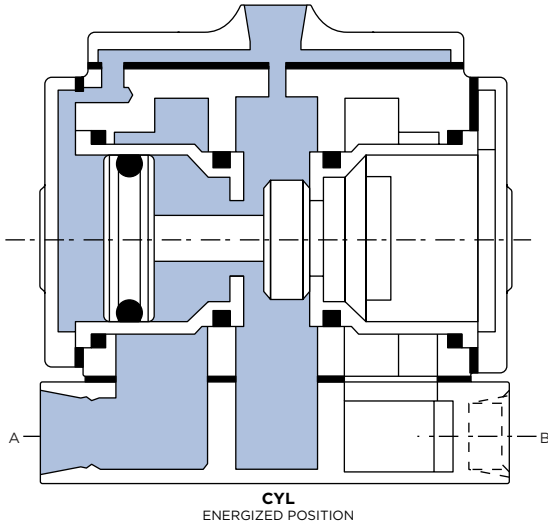
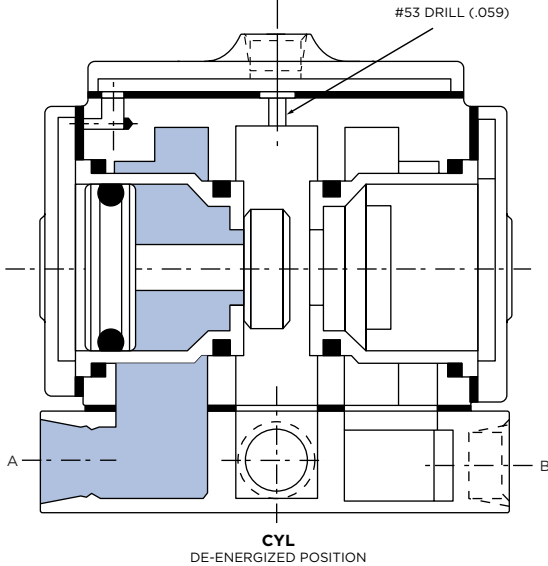
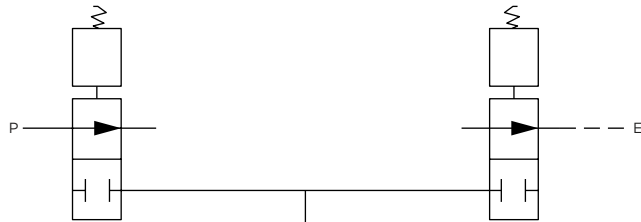

■ PRESSURE      □ EXHAUST

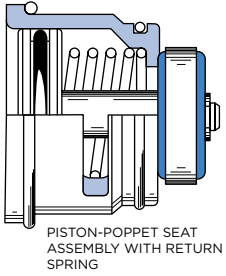

## DIRECT CURRENT SOLENOIDS

Drawings on this page give dimensions of D.C. solenoids mounted on standard NOPAK-Matic pilot heads. All other valve dimensions are the same as shown on each catalog sheet. Solenoids for 12, 16, 24, 32, 50, 90, 125 and 250 D.C. are in stock. Other voltages are available on request. For complete cost data, see price sheet.

**NOTE:** Both single and double solenoid valves use No. 24-80 solenoids with coils No. 9-27 (watts = 36) inrush amps = holding amps then for 25 volts D.C.,  $A = 36/24 = 1.5$  amps

**AMBIENT TEMPERATURES —** NOPAK-Matic valves with solenoids will function trouble-free in temperatures to 140°F. Check with NOPAK for special solenoids for temperatures in excess of 140°F.

### ENGINEERING

- Direct Current Solenoids
- Ambient Temperatures
- Pressure Drop vs. Air Flow

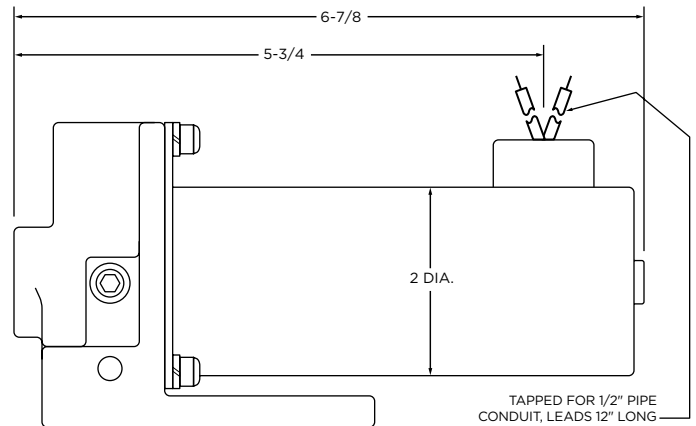

**SINGLE SOLENOID PILOT HEAD FOR SERIES 310 AND 410 VALVES**

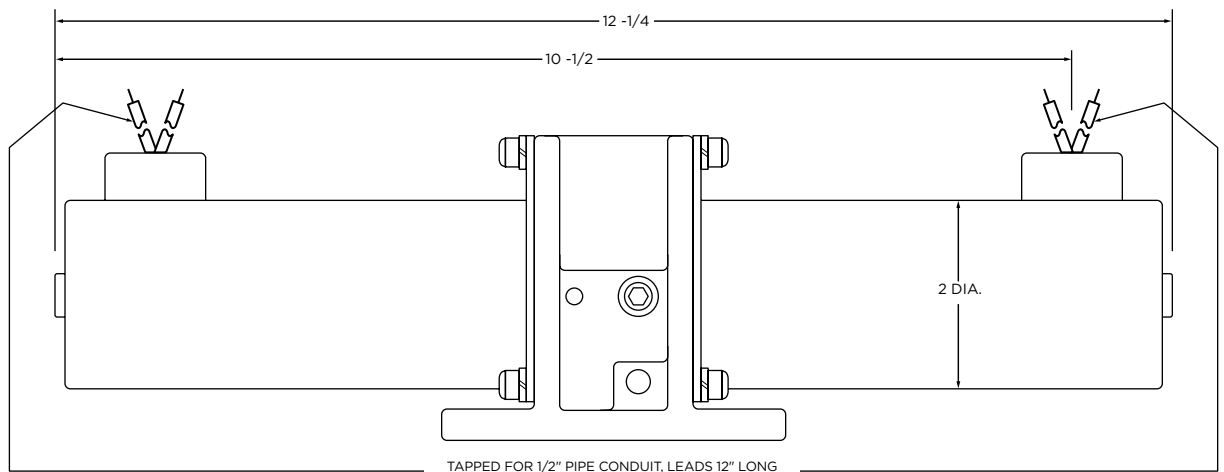

**DOUBLE SOLENOID PILOT HEAD FOR SERIES 320 AND 420 VALVES**

### USE AIR LINE FILTER, PROPER LUBRICANTS

TO ENSURE maximum performance, NOPAK-Matic Valves should be supplied with CLEAN LUBRICATED air. We recommend use of an air line filter and lubricator, BOTH OF AMPLE FLOW CAPACITY, installed as close as possible ahead of the valve and cylinder. DO NOT USE oils having any detergent additives. Following is a representative list of oil refiners and their particular brands.

**NOTE:** Chemical composition may vary somewhat due to geographical areas in which these lubricants are produced.

Cities Service Oil Co .....	North Star #2
Esso Standard Oil .....	Teresso #43 or Teresstic #43
Gulf Oil Co .....	Harmony #44 or Security #44
N.Y. & N.J. Lubricant Co .....	A-#88/HNR
Shell Oil Co .....	Tellus #27 or Turbo #27
Sinclair Refining Co .....	Rubilene-Extra Light
Saony-Mobile Oil Co .....	D.T.E. Light
Standard Oil of Calif .....	Chevron GST Oil #32
Texaco .....	Regal A.R. & O.
Union Oil of Calif .....	Red Line Turbine Oil #150

**C<sub>v</sub> FACTORS FOR NOPAK-MATIC VALVES**

To assist in the selection of NOPAK-Matic valves, the following flow coefficients of the various models and pipe sizes have been determined in accordance with the standard air flow equation:

$$C_v = \frac{Q \times 60}{1360} \sqrt{\frac{G \times T_u}{\Delta P \times P_u}}$$

in which

- C<sub>v</sub> = flow coefficient
- Q = air flow in standard units, scfm (14.7 PSI, 68°F)
- G = specific gravity, air @ 68°F
- T<sub>u</sub> = absolute temp. (deg. F + 460)
- ΔP = pressure drop, PSI
- P<sub>u</sub> = pressure in absolute units (subscript “u” = upstream)

then

$$C_v = \frac{Q \times 60}{1360} \sqrt{\frac{.932 \times (68 + 460)}{\Delta P \times (100 + 14.7)}}$$

For values of C<sub>v</sub> and pressure drops at 100 PSI entering air pressure.

For our NOPAK-Matic valves the following C<sub>v</sub> factors apply:

3-WAY			
MODEL	NPTF SIZE	C <sub>v</sub>	
		ΔP = .15	ΔP = .40
300	1/4	5.66	5.13
310	1/4	5.66	5.13
320	1/4	5.66	5.13
301	3/8	6.28	5.63
311	3/8	6.28	5.63
321	3/8	6.28	5.63
301-1/2	1/2	7.37	6.60
311-1/2	1/2	7.37	6.60
321-1/2	1/2	7.37	6.60
302	1/2	7.74	6.93
312	1/2	7.74	6.93
322	1/2	7.74	6.93
303	3/4	8.33	7.58
313	3/4	8.33	7.58
323	3/4	8.33	7.58
304	1	11.3	10.1
314	1	11.3	10.1
324	1	11.3	10.1
305	1-1/4	12.0	10.8
315	1-1/4	12.0	10.8
325	1-1/4	12.0	10.8

4-WAY			
MODEL	NPTF SIZE	C <sub>v</sub>	
		ΔP = .15	ΔP = .40
400	1/4	2.83	2.74
410	1/4	2.83	2.74
420	1/4	2.83	2.74
401	3/8	3.42	3.32
411	3/8	3.42	3.32
421	3/8	3.42	3.32
401-1/2	1/2	4.21	4.13
411-1/2	1/2	4.21	4.13
421-1/2	1/2	4.21	4.13
402	1/2	4.48	4.41
412	1/2	4.48	4.41
422	1/2	4.48	4.41
403	3/4	4.72	4.62
413	3/4	4.72	4.62
423	3/4	4.72	4.62
404	1	6.42	6.28
414	1	6.42	6.28
424	1	6.42	6.28
405	1-1/4	6.72	6.50
415	1-1/4	6.72	6.50
425	1-1/4	6.72	6.50

To determine the C<sub>v</sub> factor for supply pressure at other than 100 PSIG, calculate ΔP and Q in accordance with the information given in the Pressure Drop vs. Air Flow graph on the next page and then substitute these new values in the above equation.

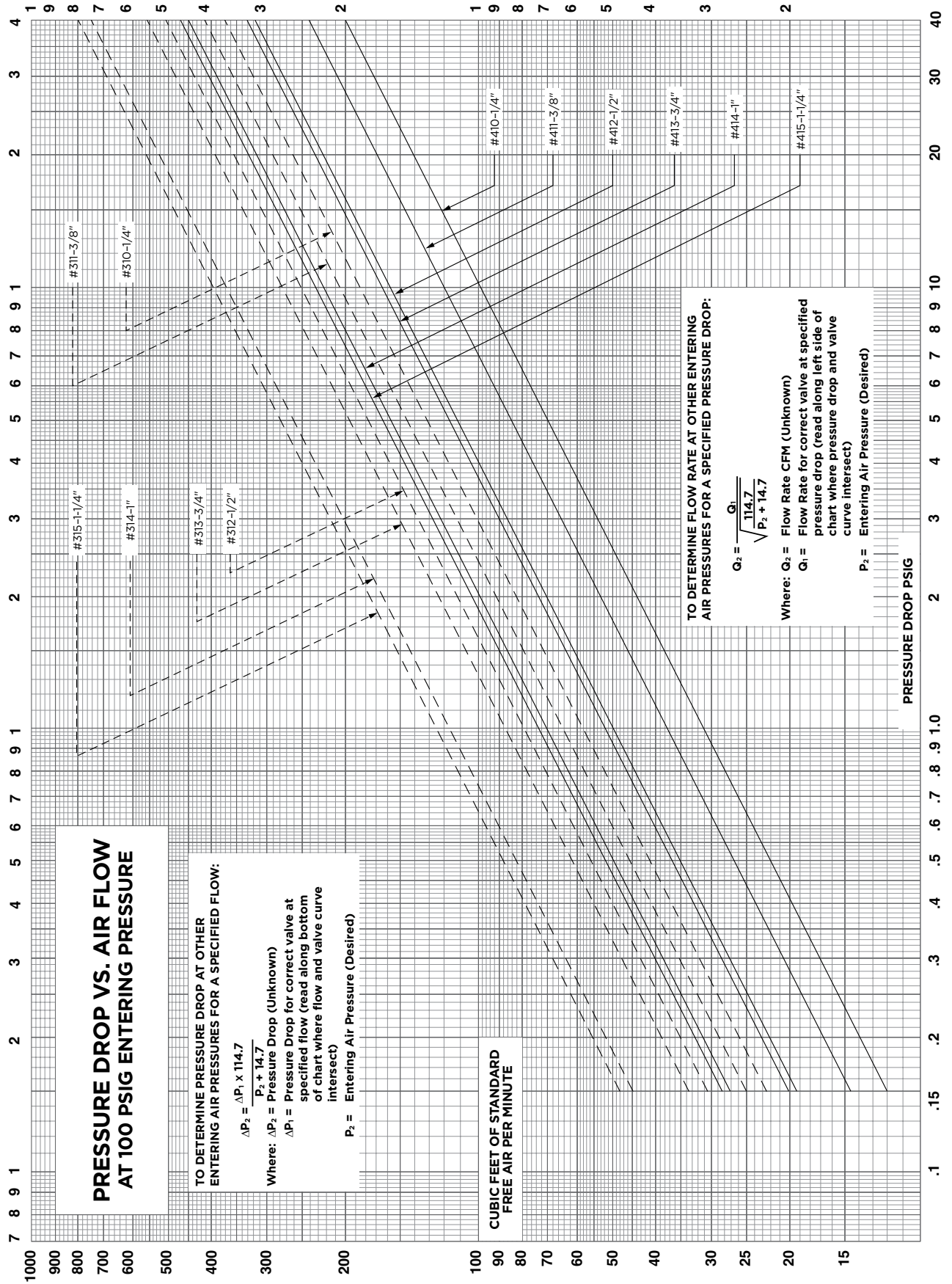

# Boosters, Intensifiers and Air/Oil Tanks

Ram and Piston Type

---



# NOPAK

First in Manufacturing. Engineered to Last.

**TABLE OF CONTENTS**

Standard Features . . . . . 174  
 Index of Selections . . . . . 175  
 Ordering Information . . . . . 176  
 How To Select The Most Efficient Booster . . . 177  
 NBS-5 Single Pressure Ram Type Booster . . 178  
 NBD-5 Dual Pressure Ram Type Booster . . . 179  
 NBS-5 Models . . . . . 180  
 NBD-5 Models . . . . . 182  
 NB3 Boosters and Accumulators . . . . . 184  
 Booster Selection Chart  
 Single Pressure NBS-5 and  
 Dual Pressure NBD-5 (5000 PSI) . . . . . 186  
 Booster Selection Chart  
 NB-3 (3000 PSI) . . . . . 187  
 Air-Oil Tanks . . . . . 188

**CUTAWAY VIEW**

**TIE RODS AND LOCKNUTS -**

Tie rod material is an alloy steel for maximum strength. Nuts are of high strength steel material and designed for self-locking.

**CYLINDER TUBING -**

Hard coated aluminum, incorporating an extremely wear-resistant surface, and low friction characteristics. Smooth bore steel tubing standard on H-6 hydraulic cylinders.

**ROD BEARINGS -**

Self-compensating to pressure, multilip vee type packing. Specifically designed for high pressure sealing and minimum leakage.

**TUBE SEAL -**

Positive controlled metal squeeze on pressure sealed O-ring.

**ROD SEALS -**

Long-wearing type bronze is concentrically machined for accurate alignment ensuring longer seal life.

**PORTS -**

Machined as an SAE dry seal national pipe thread standard.

**PISTON ASSEMBLY -**

A one-piece piston, machined from high strength cast iron. Two u-cup seals are of the pressure compensating sealing type backed up by Teflon non-extrusion washers.

**PISTON ROD -**

Hard chrome plated stressproof steel, ground and polished, 125,000 tensile Rockwell 25C.

**END CAPS AND RAM NOZZLE -**

Accurately machined from high-quality steel plate or bar stock.

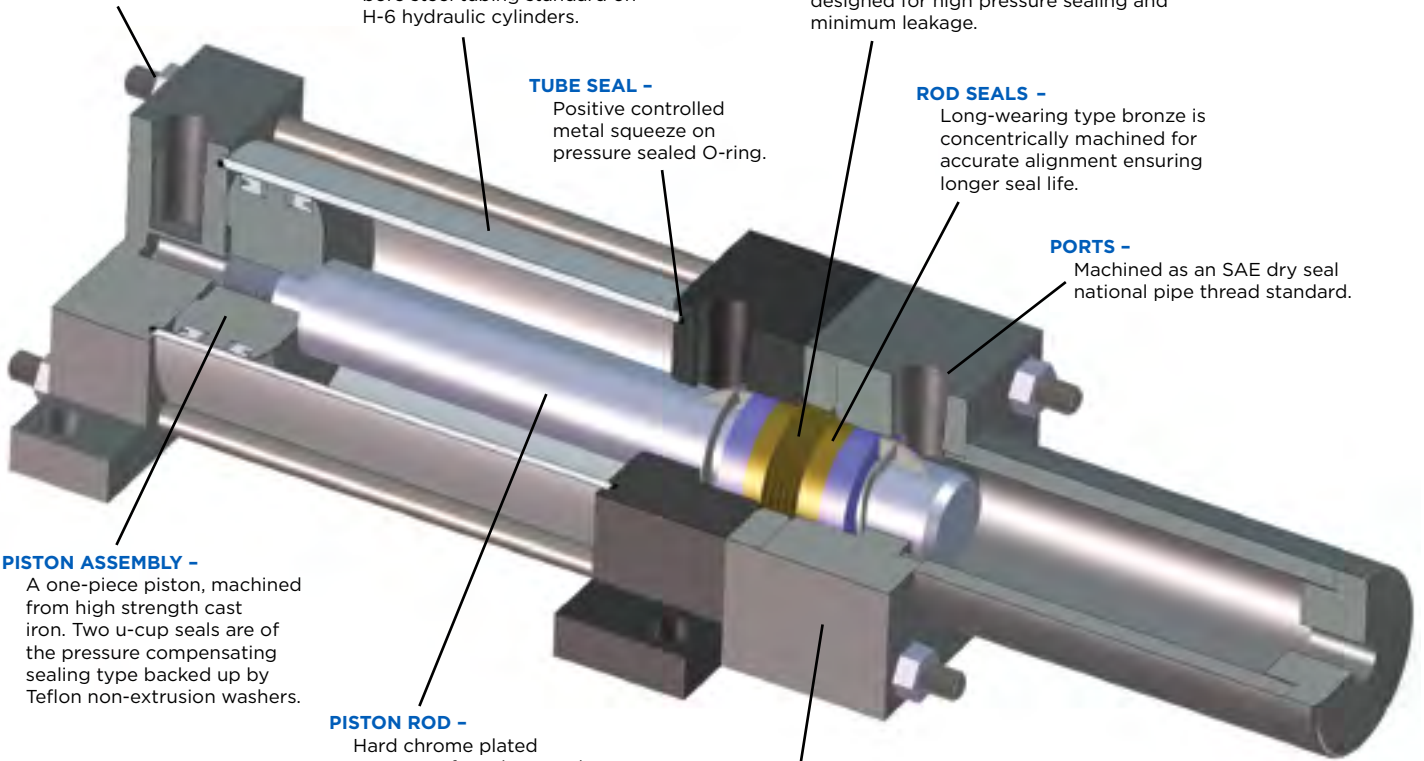

## RAM-TYPE BOOSTERS

A Booster is a device used to convert low pressure shop air to an intensified hydraulic pressure. This is accomplished by applying low pressure air to the full piston area of the low pressure side of the booster. This intensified force is transferred by means of a ram to the high pressure side of the booster. Intensification of pressure is based on the ratio in square inches between the low pressure piston and the high pressure ram.

This method of intensification eliminates costly hydraulic pumps or power pack units. It must be stated that a booster intensifier total output power is limited so that rapid cycling of a booster-cylinder combination is not feasible. Only applications where intermittent high pressure hydraulics required for a limited operation can be achieved with the booster intensifier. The unlimited bore-ram ratios makes the booster a versatile customized device. Whether your requirements are in the low, medium or high pressure range, there is a NOPAK booster available for your application.

## PISTON TYPE BOOSTERS

This type of booster can also be used as an accumulator depending on its location in the circuit. The operating principle is the same as the ram type booster except that intensification in the output cylinder is transmitted to the full area of a piston instead of the ram. The basic assembly consists of two cylinders connected as a unit using a common ram to transfer thrust from the input side of the booster. Parts for both cylinders are standard inventory for NOPAK's Class 6 air or medium pressure hydraulic cylinder. The output cylinder is a NOPAK Class 3 high pressure hydraulic cylinder. Connection of both cylinders is accomplished by means of an adapter plate. The availability and standardization of adaptable parts makes the NB-3 booster economically priced with faster delivery time. Our engineering personnel can aid and advise you with your booster selection or special applications.

## BOOSTERS WITH AIR-OIL TANK COMBINATIONS

The assembly of the air-oil tank to the booster as an integral unit will benefit users with less space required in the circuit and a savings on installation time. Tanks are mounted on the booster with a common plate and tie rods. Tanks are selected with the same diameter bore as the booster. The mounting of the booster must be in a vertical position because of the air over oil function of the tank. Ordering of this unit requires adding "T" (for tank) to booster code combinations. Examples of NOPAK standard boosters are NBT-3, NBST-5 and NBDT-5.

See page 188 and page 189 for air-oil tanks mounted separately in booster circuit.

## NOPAK NBS-5 SINGLE PRESSURE RAM TYPE BOOSTERS - 5000 PSI

Single pressure boosters are used in applications where an intensified high pressure output is required throughout the full stroke of the work cylinder. Because of the singular ram seal, this type of booster is not self-bleeding or self-filling. Special care must be taken to bleed out air when filling or installing. The NBS-5 booster has an output pressure limitation of 5000 PSI maximum.

## NOPAK NBD-5 DUAL PRESSURE RAM TYPE BOOSTERS - 5000 PSI

Dual pressure boosters are used in applications where low pressure is adequate for the approach stroke of the work cylinder and high pressure for the remainder of the stroke. The booster ram is only effective after entering the secondary seal of the high pressure side of booster. Therefore, a smaller dual booster can be used to do the job that normally it would take for a larger single booster. This type of booster is self-bleeding and self-filling. No external bleed valving is required in inlet line. The NBD-5 booster has an output pressure limitation of 5000 PSI maximum.

## NOPAK NB-3 PISTON TYPE BOOSTER AND ACCUMULATOR - 3000 PSI

Single-acting pressure boosters are used in applications where an intensified high pressure output is required throughout the full stroke of the work cylinder. Piston type boosters can be used in double-acting circuits as well. Intensification is accomplished by use of a piston instead of a ram in the output cylinder of the booster. This then makes the intensification area of the piston a factor in output computations. This type of unit can be used either as a booster or an accumulator, dependent on how it is located in the hydraulic circuit. The fact that it is assembled from stock inventory of available Class 3 and Class 6 components makes the booster economically priced. Modification of two components adapts the high pressure Class 3 to the low pressure Class 6 cylinder as a booster assembly. When applied as a booster, the unit is not self-bleeding, so provisions for this function must be made elsewhere in the hydraulic circuit. Use of stock parts makes the NB-3 booster pressure limitation at 3000 PSI maximum.

## AIR-OIL TANKS

Air-Oil Tanks offer a means of smooth hydraulic speed control of a cylinder from an air line source. In addition they may be used to prefill a circuit or for low pressure advance of a work cylinder.

**HOW TO ORDER**

**ORDERING CODE EXAMPLE - RAM TYPE BOOSTER**

**NBS-5** (NOPAK Booster Single pressure 5000 PSI output max.) / **NBD-5** (NOPAK Booster Dual pressure 5000 PSI output max.)

**1 - A - 6 - NBS5 - 5 x 14 - ΔΔ - 1-3/8 - 3/4 NPT - OPT**

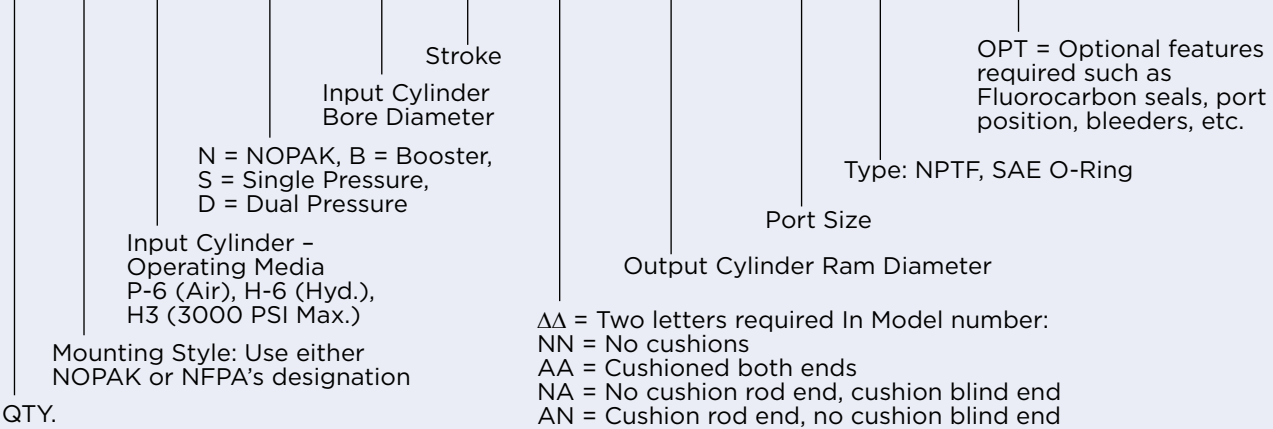

**ORDERING CODE EXAMPLE - PISTON TYPE BOOSTER**

**NB3** (NOPAK Booster 3000 PSI output max.)

**1 - 6 - NB3 - 6 x 14 A - NN - 3/4 NPT - 2 - 3-3.250 x 14 H - 3/4 NPT - OPT**

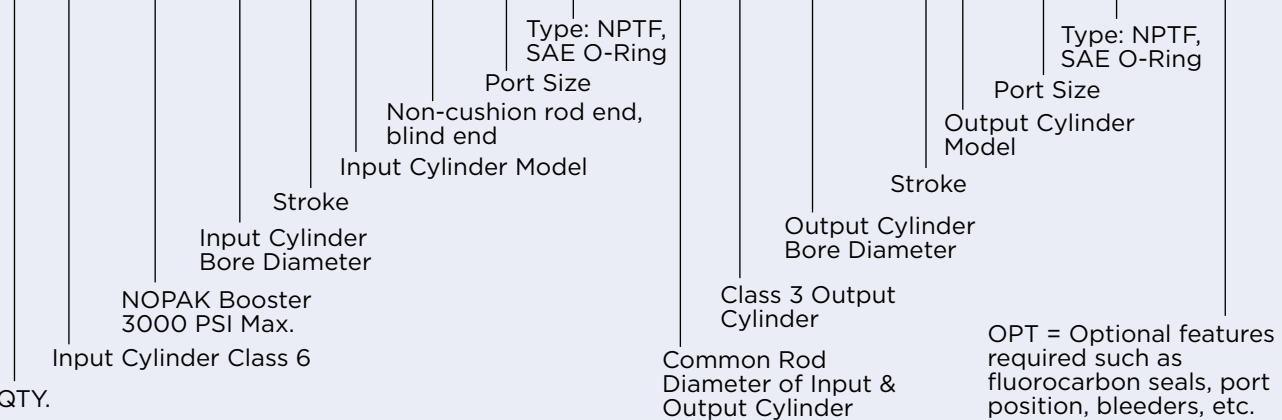

**ORDERING CODE EXAMPLE - AIR-OIL TANKS**

**1 - EP<sup>OR</sup> - H6 - 6 x 8 - AP - OPT**

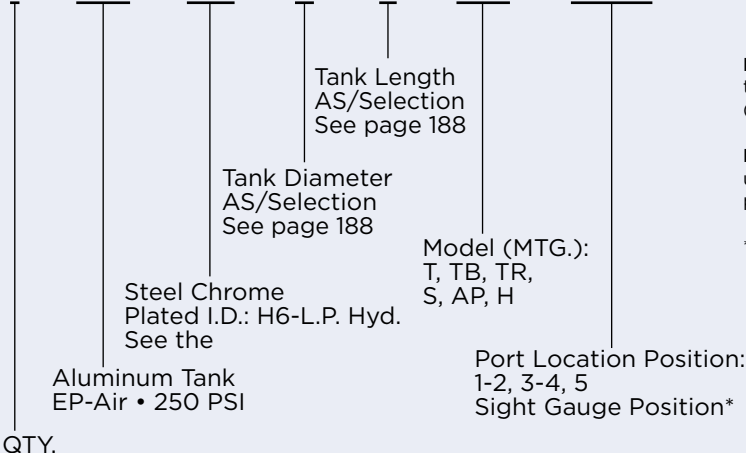

**MATERIAL NOTE:** Aluminum heads (Class EP stock) for tank diameter 3-1/4 through 8" diameter steel heads (Class H6 stock) for tank diameters 10-12-14

**NOTE:** Unless specified, Air-Oil Tanks shall be a separate unit in the Booster Circuit, as illustrated on page 188 and page 189.

\* = Sight gauge is considered to be in position 1 in all cases unless specifically called out otherwise. See page 189.



# HOW TO SELECT THE MOST EFFICIENT BOOSTER

## STEP 1. SELECTING A SINGLE PRESSURE BOOSTER

Preliminary information needed:

- A** Thrust force or load required from work cylinder for application.
- B** Bore diameter of work cylinder and stroke length required to do the job (select a force greater than that required as a margin of safety).
- C** Input PSI pressure of work cylinder needed to obtain force selected.
- D** Available input PSI pressure to operate booster.
- E** Booster ratio.

### EXAMPLE:

Your application requires a thrust or force of 4,400 lbs. for 4" length.

From Class 3 Section Table C "Thrust Force and Displacement" you read 4,909 lbs. for a 2-1/2" diameter cylinder which requires an input pressure of 1,000 PSI to obtain this force. This allows a 500# force margin of safety.

Your available input pressure at site is 80 PSI shop air. Booster ratio can now be determined.

$$\text{ratio} = \frac{\text{output pressure}}{\text{input pressure}} = \frac{1,000}{80} = 12.5$$

You have now established that:

- A** Work cylinder force = 4,900 lbs.
- B** Work cylinder diameter = 2-1/2" bore  
Work cylinder stroke = 4" length
- C** Booster output pressure = 1,000 PSI
- D** Available input pressure = 80 PSI shop air
- E** Booster ratio = 12.5

## STEP 2. SELECT BOOSTER BORE AND RAM SIZE

Using ratio from above Item E, select from Booster Selection Chart, page 186, the bore and ram size that reads closest to ratio. If exact ratio is not shown, then select next larger ratio. Next check if input PSI corresponds to application availability Item D above.

Read down input PSI column to output PSI that is equal or greater than Item C above. If table output is larger than needed then the ratio can be recalculated.

Now with your recalculated ratio, input pressure and closest output pressure, you can now read the booster bore diameter and ram size needed.

## STEP 3. DETERMINE BOOSTER STROKE

Calculate the booster stroke using formula

$$S = \frac{V + VcL}{Ra}$$

S = Booster stroke

V = Volume cubic inch of 2-1/2" bore work cylinder times 4" stroke or 19.6 cu. in.

VcL = Volume cubic inch plus oil volume cu. in. in circuit lines (20 cu. in. FOR THIS EXAMPLE) TIMES 1% PER 1,000 PSI OR .01

Ra = Area of 1-3/8" diameter ram or 1.485 sq. in.

**NOTE:** Substitute Pa (piston area) for Ra (ram area) in the above formula when calculating a piston type booster or accumulator.

$$S = \frac{19.6 + (19.6 + 20).01}{1.485}$$

$$S = \frac{19.996}{1.485} = 13.46 \text{ or } 14" \text{ stroke}$$

**NOTE:** To account for leakage (hydraulic slip) or any other uncertainties, a factor of safety of 20% should be added.

$$S = 14" \times 1.20 = 16.8 \text{ OR } 17" \text{ STROKE}$$

From the following determining selection you would then order:

A 5" diameter single pressure NBS-5 booster with a 17" stroke using a 1-3/8 diameter ram. With an input pressure of 80 PSI air to be intensified to 1,058 PSI for full 4" stroke of 2-1/2" bore work cylinder with a recalculated ratio of 13.22.

## SELECTING A DUAL PRESSURE BOOSTER

Steps No. 1 and 2 are the same as a single pressure booster. Proceed with step No. 3.

## STEP 3. DETERMINE BOOSTER STROKE

Calculate the booster stroke using formula.

$$S = \frac{V + VcL}{Ra} + 2 \text{ inch stroke required to close H.P. Seal}$$

**NOTE:** For larger boosters with 3" diameter rod and over, use 3" plus calculated booster stroke.

S = Booster stroke

V = Volume cubic inch of 2-1/2" bore work cylinder times H.P. stroke length or 4.9 sq. in. x 1" = 4.9 cu. in. of H.P. stroke

VcL = Volume cu. in. plus oil volume cu. in. in circuit lines or 20 cu. in. times 1% per 1,000 PSI or .01

Ra = Area of 1-3/8" diameter ram or 1.485 sq. in.

**NOTE:** Substitute Pa (piston area) for Ra (ram area) in the above formula when calculating a piston type booster or accumulator.

$$S = \frac{4.9 + (19.6 + 20).01}{1.485} + 2$$

$$S = \frac{5.30}{1.485} + 2$$

S = 5.56 or 6" Booster stroke

S = 6 X 1.20 = 7.2 or 8" stroke (see note above).

From the following determining selection you would then order: A 5" diameter dual pressure NBD-5 booster with an 8" stroke using a 1-3/8" diameter ram. With an input pressure of 80 PSI air to be intensified to 1,058 PSI for last 1" stroke of 2-1/2" bore work cylinder with recalculated ratio of 13.22.

**NBS-5 SINGLE PRESSURE RAM TYPE BOOSTER**

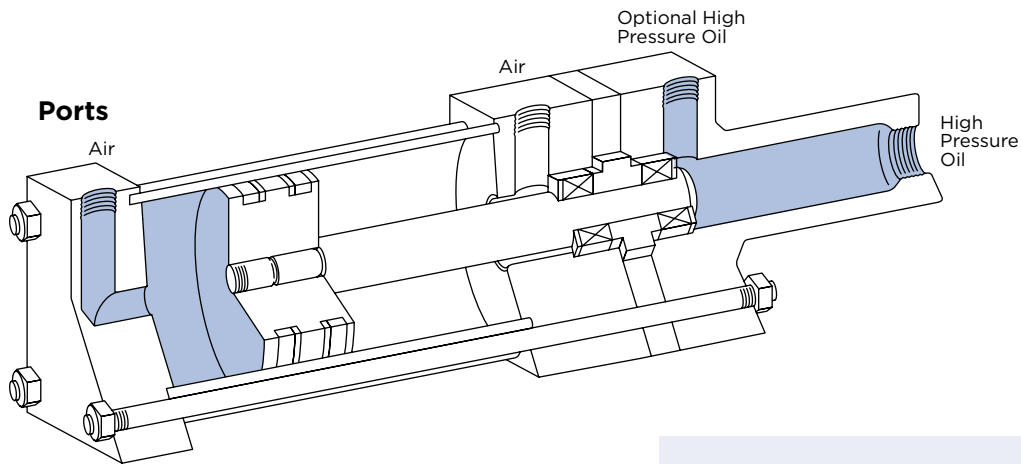

This type booster has a single ram seal so the entire stroke is of intensified high pressure.

Low pressure air is directed to the booster input cylinder port to the cylinder chamber. Making contact with the larger surface of the retracted piston forces the piston with ram, forward, to begin the cylinder stroke. Low pressure oil is intensified in the nozzle chamber by the ram end force created by the larger air piston pushing. The high pressure oil is forced out of the nozzle port into the work cylinder for a high pressure continuous stroke. Oil flows out and back in through the nozzle port or can be piped in through the optional port located in the nozzle head. Makeup oil is provided from an external replenishing valve. The booster ratio of input and output pressure rated values are charted on page 186.

Booster Series NBS is similar to the dual pressure Series NBD except the center head which contains the port and seal for low pressure oil has been eliminated. Therefore, the primary purpose of this design is to provide high pressure oil to the work cylinder during its entire stroke.

Since the booster is neither self-filling or self-venting, provisions should be made to perform these operations in the external circuit.

See Booster Selection Chart, page 186 and "How To Select The Most Efficient Booster" on page 177.

**TYPICAL SINGLE PRESSURE CIRCUIT**

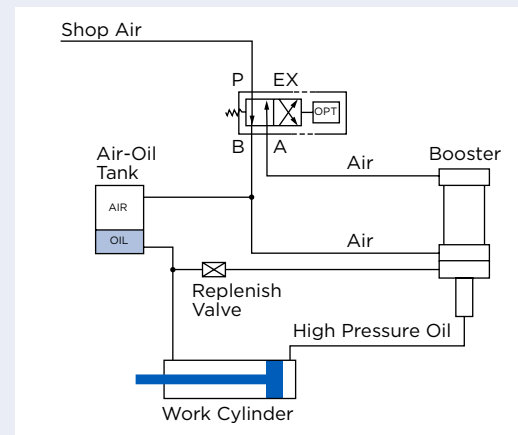

### NBD-5 DUAL PRESSURE RAM TYPE BOOSTER

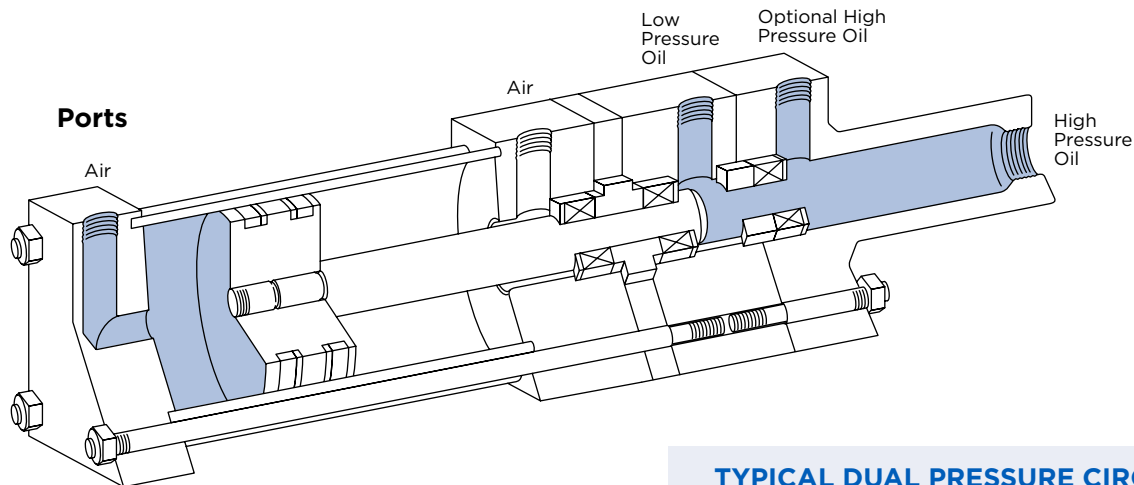

The dual pressure booster is used where the work cylinder is required to travel a short distance at high pressure after a substantial low pressure advance stroke. Because the booster ram operates only during the high pressure portion of the work stroke, a shorter booster stroke is required. In the fully retracted position, the ram is withdrawn from the high pressure ram seal allowing low pressure “approach stroke” oil to pass through to the work cylinder. This design makes the booster both self-filling and self-bleeding.

See Booster Selection Chart, page 186 and “How To Select The Most Efficient Booster” on page 177.

Low pressure air is directed to the Booster input cylinder port into the cylinder chamber. Making contact with the large surface of the retracted piston forces the piston with ram forward to start the cylinder stroke.

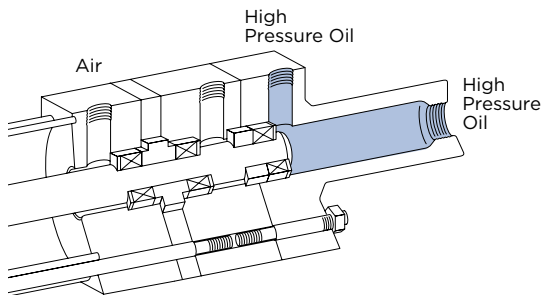
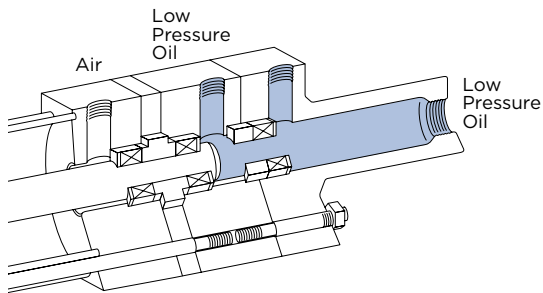
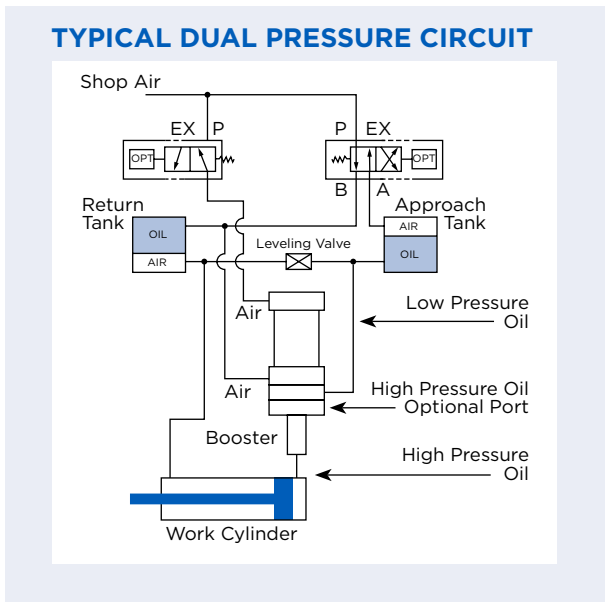

Low pressure oil is flowing through the low pressure port into and through the high pressure bearing I.D. and seal. It continues through the nozzle chamber and out the port to the work cylinder. The ram is traveling under the same pressure as the input air. The low pressure oil reaching the work cylinder forces the rod forward which is called “the approach stroke.”

The booster ram traveling forward now enters the high pressure bearing and seal cutting off the low pressure oil supply. The ram end force created by the large air piston now greatly intensifies the oil pressure contained in the nozzle chamber and is pushed out of the high pressure port to the work cylinder. This short stroke of the work cylinder is called the “high pressure stroke” of the work cycle. The booster ratio of input and output pressure rated values are charted on page 186. The input cylinder segment of NBD-5 boosters can be operated either with air or low pressure hydraulics. See the pressure limitations shown on page 186.

### MODEL A (NFPA STD. MS2)

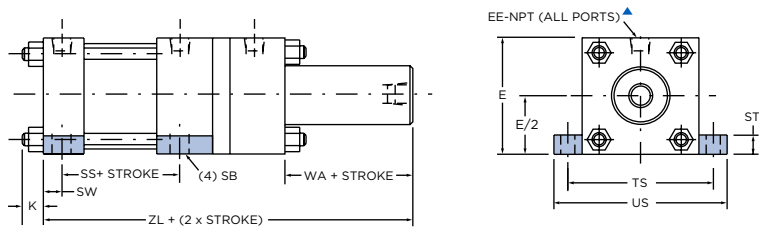

### MODEL AP (NFPA STD. STYLE MS1)

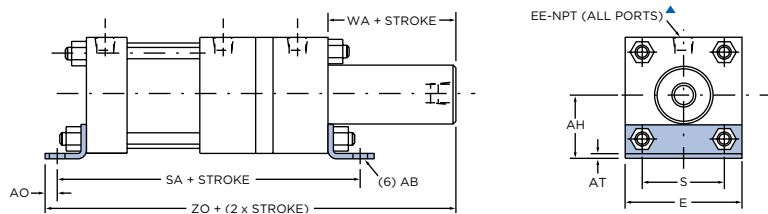

For 2-1/2" diameter through 5" diameter bore, this model is available for small ram diameter only.

### MODEL CJ (NFPA STD. STYLE ME4) 8" THROUGH 14" DIA.

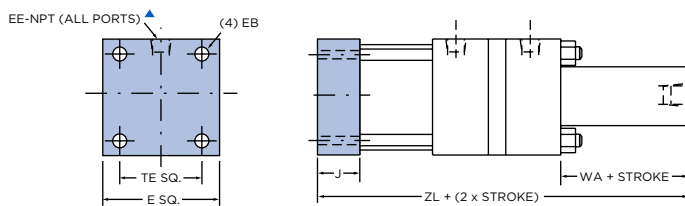

### MODEL C (NFPA STD. STYLE MF2) 2-1/2" THROUGH 6" DIA.

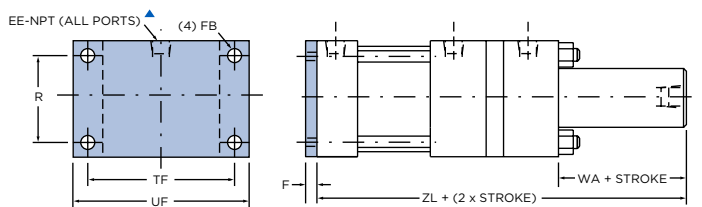

### MODEL TB (NFPA STD. STYLE MX2)

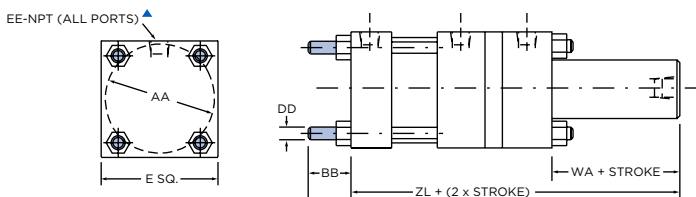

▲ = Large unrestricted ports conforming to NFPA standards are provided. They can be rotated to any 90° position in relation to each other and the booster mounting.

**Table 1**

• = Dimension refers to bolt diameter.

BORE DIA.	INPUT CYLINDER PSI		MOUNTING DIMENSIONS													
	AIR	HYD.	E	F	K	R	S	AA	AB•	AH	AO	AT	BB	DD	EB•	EE
2-1/2	250	1100	3	3/8	5/16	2.19	2-1/4	3.10	3/8	1-5/8	3/8	1/8	1-1/8	5/16-24	-	3/8
3-1/4	250	1350	3-3/4	5/8	7/16	2.76	2-3/4	4.00	1/2	2	1/2	1/8	1-3/8	7/16-20	-	1/2
4	250	950	4-1/2	5/8	7/16	3.32	3-1/2	4.75	1/2	2-1/4	1/2	1/8	1-3/8	7/16-20	-	1/2
5	250	900	5-1/2	5/8	1/2	4.10	4-1/4	5.80	5/8	2-3/4	5/8	3/16	1-3/4	1/2-20	-	1/2
6	200	750	6-1/2	3/4	9/16	4.88	5-1/4	6.90	3/4	3-1/4	5/8	3/16	1-3/4	9/16-18	-	3/4
8	200	500	8-1/2	3/4	5/8	-	7-1/8	9.10	3/4	4-1/4	11/16	1/4	2-1/4	5/8-18	5/8	3/4
10	200	400	10-5/8	3/4	3/4	-	8-7/8	11.31	1	5-5/16	7/8	1/4	2-5/8	3/4-16	3/4	1
12	200	400	12-3/4	3/4	3/4	-	11	13.30	1	6-3/8	7/8	3/8	2-11/16	3/4-16	3/4	1
14	200	400	14-3/4	3/4	7/8	-	12-5/8	15.40	1-1/4	7-3/8	1-1/16	3/8	3-3/16	7/8-14	7/8	1-1/4

**Table 2**

• = Dimension refers to bolt diameter.

BORE DIA.	INPUT CYLINDER PSI		MOUNTING DIMENSIONS												
	AIR	HYD.	FB•	SA	SB•	SS	ST	TE	TF	TS	UF	US	WA	ZL	ZO
2-1/2	250	1100	5/16	7-5/8	3/8	3	1/2	-	3-7/8	3-3/4	4-5/8	4-1/2	5/8	6-1/4	7-1/4
3-1/4	250	1350	3/8	9-1/8	1/2	3-1/4	3/4	-	4-11/16	4-3/4	5-1/2	5-3/4	5/8	7-1/4	9
4	250	950	3/8	9-1/8	1/2	3-1/4	3/4	-	5-7/16	5-1/2	6-1/4	6-1/2	5/8	7-1/4	9
5	250	900	1/2	9-5/8	3/4	3-1/8	1	-	6-5/8	6-7/8	7-5/8	8-1/4	5/8	7-1/2	9-1/2
6	200	750	1/2	10-1/2	3/4	3-5/8	1	-	7-5/8	7-7/8	8-5/8	9-1/4	7/8	8-5/8	10-5/8
8	200	500	-	11-1/2	3/4	3-3/4	1	7.57	-	9-7/8	-	11-1/4	7/8	8-3/4	11-1/4
10	200	400	-	13-5/8	1	4-5/8	1-1/4	9.40	-	12-3/8	-	14-1/8	1-1/8	10-1/2	13-1/2
12	200	400	-	14-1/8	1	5-1/8	1-1/4	11.10	-	14-1/2	-	16-1/4	1-1/8	11	14
14	200	400	-	16-1/2	1-1/4	5-7/8	1-1/2	12.87	-	17	-	19-1/4	1-5/8	13-1/4	16-3/4

### MODEL A (NFPA STD. MS2)

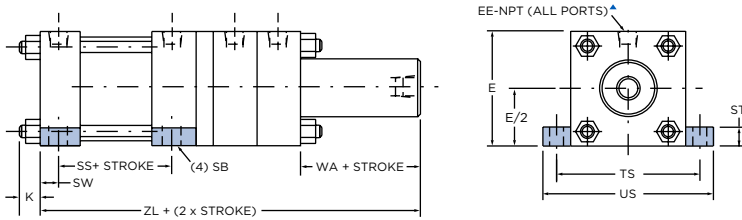

### MODEL AP (NFPA STD. STYLE MS1)

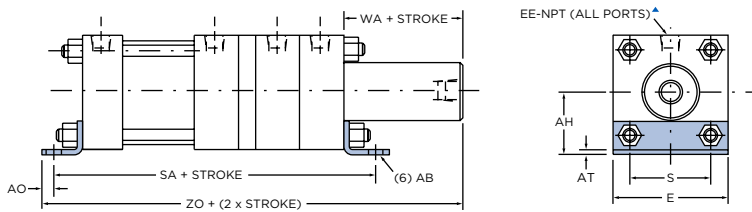

For 2-1/2" diameter through 5" diameter bore, this model is available for small ram diameter only.

### MODEL CJ (NFPA STD. STYLE ME4) 8" THROUGH 14" DIA.

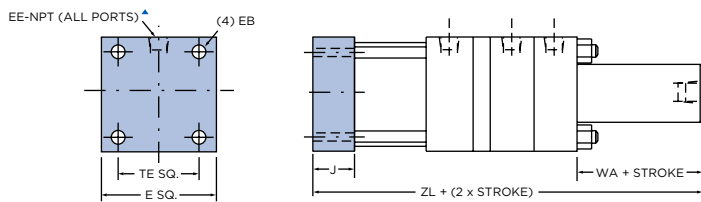

### MODEL C (NFPA STD. STYLE MF2) 2-1/2" THROUGH 6" DIA.

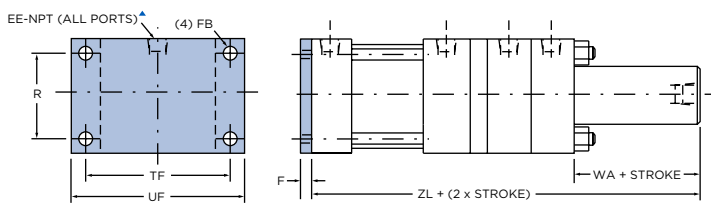

### MODEL TB (NFPA STD. STYLE MX2)

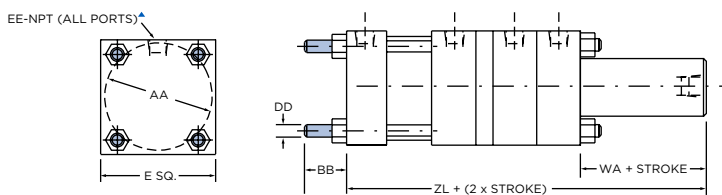

▲ = Large unrestricted ports conforming to NFPA standards are provided. They can be rotated to any 90° position in relation to each other and the booster mounting.

**Table 1**

• = Dimension refers to bolt diameter.

BORE DIA.	INPUT CYLINDER PSI		MOUNTING DIMENSIONS														
	AIR	HYD.	E	F	J	K	R	S	AA	AB•	AH	AO	AT	BB	DD	EB•	EE
2-1/2	250	1100	3	3/8	1-1/8	5/16	2.19	2-1/4	3.10	3/8	1-5/8	3/8	1/8	1-1/8	5/16-24	-	3/8
3-1/4	250	1350	3-3/4	5/8	1-1/4	7/16	2.76	2-3/4	4.00	1/2	2	1/2	1/8	1-3/8	7/16-20	-	1/2
4	250	950	4-1/2	5/8	1-1/4	7/16	3.32	3-1/2	4.75	1/2	2-1/4	1/2	1/8	1-3/8	7/16-20	-	1/2
5	250	900	5-1/2	5/8	1-1/4	1/2	4.10	4-1/4	5.80	5/8	2-3/4	5/8	3/16	1-3/4	1/2-20	-	1/2
6	200	750	6-1/2	3/4	1-1/2	9/16	4.88	5-1/4	6.90	3/4	3-1/4	5/8	3/16	1-3/4	9/16-18	-	3/4
8	200	500	8-1/2	3/4	1-1/2	5/8	-	7-1/8	9.10	3/4	4-1/4	11/16	1/4	2-1/4	5/8-18	5/8	3/4
10	200	400	10-5/8	3/4	2	3/4	-	8-7/8	11.31	1	5-5/16	7/8	1/4	2-5/8	3/4-16	3/4	1
12	200	400	12-3/4	3/4	2	3/4	-	11	13.30	1	6-3/8	7/8	3/8	2-11/16	3/4-16	3/4	1
14	200	400	14-3/4	3/4	2-1/4	7/8	-	12-5/8	15.40	1-1/4	7-3/8	1-1/16	3/8	3-3/16	7/8-14	7/8	1-1/4

**Table 2**

• = Dimension refers to bolt diameter.

BORE DIA.	INPUT CYLINDER PSI		MOUNTING DIMENSIONS													
	AIR	HYD.	FB•	SA	SB•	SS	ST	SW	TE	TF	TS	UF	US	WA	ZL	ZO
2-1/2	250	1100	5/16	9-1/8	3/8	3	1/2	3/8	-	3-7/8	3-3/4	4-5/8	4-1/2	5/8	7-3/4	9-1/8
3-1/4	250	1350	3/8	10-7/8	1/2	3-1/4	3/4	1/2	-	4-11/16	4-3/4	5-1/2	5-3/4	5/8	9	10-3/4
4	250	950	3/8	10-7/8	1/2	3-1/4	3/4	1/2	-	5-7/16	5-1/2	6-1/4	6-1/2	5/8	9	10-3/4
5	250	900	1/2	11-3/8	3/4	3-1/8	1	11/16	-	6-5/8	6-7/8	7-5/8	8-1/4	5/8	9-1/4	11-1/4
6	200	750	1/2	12-1/2	3/4	3-5/8	1	11/16	-	7-5/8	7-7/8	8-5/8	9-1/4	7/8	10-5/8	12-5/8
8	200	500	-	13-1/2	3/4	3-3/4	1	11/16	7.57	-	9-7/8	-	11-1/4	7/8	10-3/4	13-1/4
10	200	400	-	15-7/8	1	4-5/8	1-1/4	7/8	9.40	-	12-3/8	-	14-1/8	1-1/8	12-3/4	15-3/4
12	200	400	-	16-3/8	1	5-1/8	1-1/4	7/8	11.10	-	14-1/2	-	16-1/4	1-1/8	13-1/4	16-1/4
14	200	400	-	19-1/4	1-1/4	5-7/8	1-1/2	1-1/8	12.87	-	17	-	19-1/4	1-5/8	16	19-1/2

## PISTON TYPE BOOSTERS AND ACCUMULATORS NB3

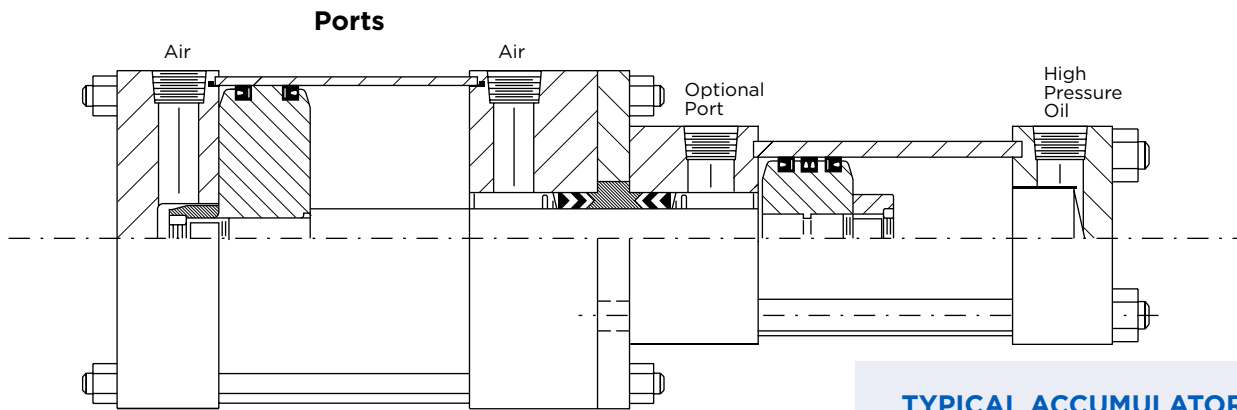

### PISTON TYPE BOOSTERS AND ACCUMULATORS NB3

Piston type boosters and accumulators consist of two cylinders with a common ram, joined together as an integral unit. This unit may be used as a booster or accumulator depending on how it is located in hydraulic circuit. When used as a booster, it is not self-bleeding so provisions must be made in the external circuit to bleed the system after each operation and before refilling.

See Booster Selection Chart, page 186 and "How To Select The Most Efficient Booster" on page 177.

### TYPICAL ACCUMULATOR CIRCUIT

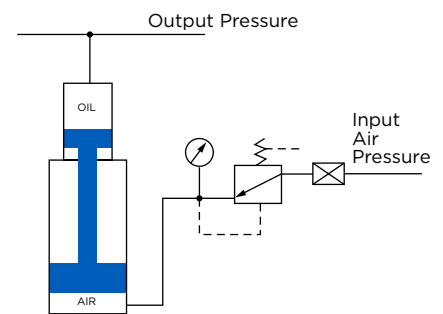

### MODEL A (NFPA STD. MS2)

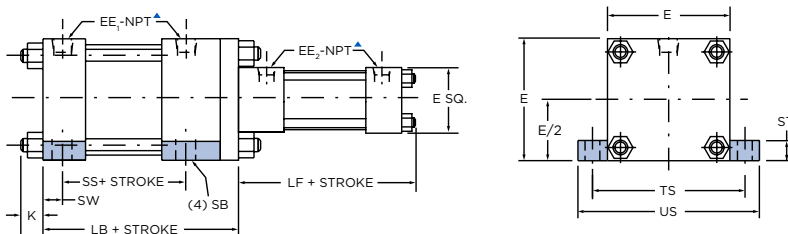

### MODEL CJ (NFPA STD. STYLE ME4) 8" THROUGH 14" DIA.

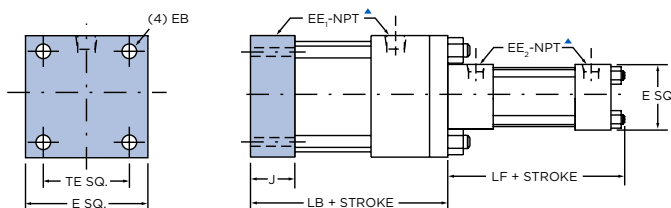

### MODEL C (NFPA STD. STYLE MF2) 2-1/2" THROUGH 6" DIA.

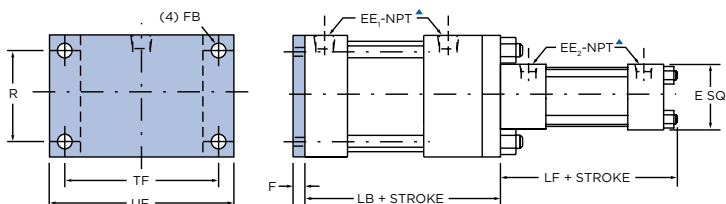

▲ = Large unrestricted ports conforming to NFPA standards are provided. They can be rotated to any 90° position in relation to each other and the booster mounting.



# NB3 BOOSTERS AND ACCUMULATORS

OUTPUT PRESSURE UP TO 3000 PSI

## MODEL TB (NFPA STD. STYLE MX2)

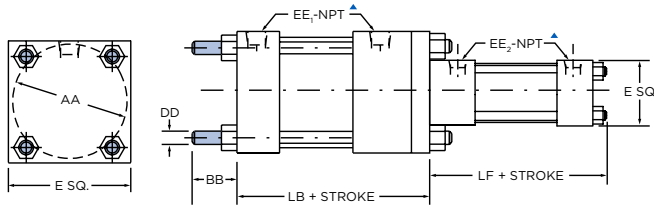

### Table 1

		INPUT CYLINDER DIMENSIONS A/L ■								
BORE		2-1/2	3-1/4	4	5	6	8	10	12	14
PSI	A ■	250	250	250	250	200	200	200	200	200
	L ■	1100	1350	950	900	750	500	400	400	400
	E	3	3-3/4	4-1/2	5-1/2	6-1/2	8-1/2	10-5/8	12-3/4	14-3/4
	F	3/8	5/8	5/8	5/8	3/4	3/4	3/4	3/4	3/4
	J	1-1/8	1-1/4	1-1/4	1-1/4	1-1/2	1-1/2	2	2	2-1/4
	K	5/16	7/16	7/16	1/2	9/16	5/8	3/4	3/4	7/8
	R	2.19	2.76	3.32	4.10	4.88	-	-	-	-
	AA	3.10	4.00	4.75	5.80	6.90	9.10	11.31	13.30	15.40
	BB	5/16-24	1-3/8	1-3/8	1-3/4	1-3/4	2-1/4	2-5/8	2-11/16	3-3/16
	DD	-	7/16-20	7/16-20	1/2-20	9/16-18	5/8-18	3/4-16	3/4-16	7/8-14
	EB •	3/8	-	-	-	-	5/8	3/4	3/4	7/8
	EE <sub>1</sub> ▲	5/16	1/2	1/2	1/2	3/4	3/4	1	1	1-1/4
	FB •	4-1/8	3/8	3/8	1/2	1/2	-	-	-	-
	LB	3/8	4-7/8	4-7/8	5-1/8	5-3/4	5-7/8	7-1/8	7-5/8	8-7/8
	SB •	3	1/2	1/2	3/4	3/4	3/4	1	1	1-1/4
	SS	1/2	3-1/4	3-1/4	3-1/8	3-5/8	3-3/4	4-5/8	5-1/8	5-7/8
	ST	3/8	3/4	3/4	1	1	1	1-1/4	1-1/4	1-1/2
	SW	-	1/2	1/2	11/16	11/16	11/16	7/8	7/8	1-1/8
	TE	3-7/8	-	-	-	-	7.57	9.40	11.10	12.87
	TF	3-3/4	4-11/16	5-7/16	6-5/8	7-5/8	-	-	-	-
	TS	4-5/8	4-3/4	5-1/2	6-7/8	7-7/8	9-7/8	12-3/8	14-1/2	17
	UF	4-1/2	5-1/2	6-1/4	7-5/8	8-5/8	-	-	-	-
	US	4-1/2	5-3/4	6-1/2	8-1/4	9-1/4	11-1/4	14-1/8	16-1/4	19-1/4

### Table 2

		OUTPUT CYLINDER DIMENSIONS A/L ■							
BORE		1-1/2	2	2-1/2	3-1/4	4	5	6	8
PSI	A ■	250	250	250	250	250	250	200	200
	L ■	1500	1500	1100	1350	950	900	750	500
	E	2	2-1/2	3	3-3/4	4-1/2	5-1/2	6-1/2	8-1/2
	EE <sub>2</sub> ▲	3/8	3/8	3/8	1/2	1/2	1/2	3/4	3/4
	LF	3-7/8	4-1/16	4-1/16	4-11/16	4-11/16	5	5-9/16	5-3/4

### Table 3

		OUTPUT CYLINDER DIMENSIONS H ■							
BORE		1-1/2	2	2-1/2	3-1/4	4	5	6	8
PSI	H ■	3000	3000	3000	3000	3000	3000	3000	3000
	E	2-1/2	3	3-1/2	4-1/2	5	6-1/2	7-1/2	9-1/2
	EE <sub>2</sub> ▲	1/2	1/2	1/2	3/4	3/4	3/4	1	1-1/2
	LF	5-1/8	5-1/8	5-3/8	6-1/4	6-1/2	7-1/4	8-1/2	10-7/8

• = Dimension refers to bolt diameter.

■ A = Air

L = L.P. Hydraulics

H = H.P. Hydraulics 3000 PSI

▲ = Large unrestricted ports conforming to NFPA standards are provided.

They can be rotated to any 90° position in relation to each other and the booster mounting.

DRIVING CYLINDER		PRESSURE RATING	OUTPUT RAM		BOOSTER RATIO*	INTENSIFIED OUTPUT HYDRAULIC PRESSURE (PSI) AT INPUT PRESSURE											
BORE	AREA	AIR HYD.	DIA.	AREA		60	80	100	200	250	400	500	750	900	950	1100	1350
2-1/2	4.909	250 1100	0.625	0.307	16.00	960	1280	1600	3200	4000	6401	8001	12001	14401	15201	17601	-
			1	0.785	6.25	375	500	625	1250	1563	2500	3125	4688	5625	5938	6876	-
			1.375	1.485	3.31	198	264	331	661	827	1322	1653	2480	2975	3141	3637	-
			1.75	2.405	2.04	122	163	204	408	510	816	1020	1531	1837	1939	2245	-
			2	3.142	10.56	634	845	1056	2113	2641	4225	5282	7922	9507	10035	11619	14260
3-1/4	8.296	250 1350	1.375	1.485	5.59	335	447	559	1117	1397	2235	2794	4190	5028	5308	6146	7543
			1.75	2.405	3.45	207	276	345	690	862	1380	1725	2587	3104	3277	3794	4656
			2	3.142	2.64	158	211	264	528	660	1056	1320	1981	2377	2509	2905	3565
			1	0.785	16.00	960	1280	1600	3200	4000	6400	8000	12000	14400	15200	-	-
			1.375	1.485	8.46	508	677	846	1693	2116	3385	4231	6347	7617	8040	-	-
4	12.566	250 950	1.75	2.405	5.22	313	418	522	1045	1306	2090	2612	3918	4702	4963	-	-
			2	3.142	4.00	240	320	400	800	1000	1600	2000	3000	3600	3800	-	-
			2.5	4.909	2.56	154	205	256	512	640	1024	1280	1920	2304	2432	-	-
			1	0.785	25.00	1500	2000	2500	5000	6250	10000	12500	18750	22500	-	-	-
			1.375	1.485	13.22	793	1058	1322	2645	3306	5289	6611	9917	11901	-	-	-
5	19.634	250 900	1.75	2.405	8.16	490	653	816	1633	2041	3265	4082	6122	7347	-	-	-
			2	3.142	6.25	375	500	625	1250	1562	2500	3125	4687	5625	-	-	-
			2.5	4.909	4.00	240	320	400	800	1000	1600	2000	3000	3600	-	-	-
			3	7.068	2.78	167	222	278	556	694	1111	1389	2083	2500	-	-	-
			3.5	9.621	2.04	122	163	204	408	510	816	1020	1531	1837	-	-	-
			1.375	1.485	19.04	1142	1523	1904	3808	4760	7617	9521	14281	-	-	-	-
			1.75	2.405	11.76	705	940	1176	2351	2939	4702	5878	8816	-	-	-	-
			2	3.142	9.00	540	720	900	1800	2250	3600	4500	6750	-	-	-	-
			2.5	4.909	5.76	346	461	576	1152	1440	2304	2880	4320	-	-	-	-
			3	7.068	4.00	240	320	400	800	1000	1600	2000	3000	-	-	-	-
6	28.274	200 750	3.5	9.621	2.94	176	235	294	588	735	1176	1469	2204	-	-	-	-
			4	12.566	2.25	135	180	225	450	563	900	1125	1688	-	-	-	-
			1.375	1.485	33.85	2031	2708	3385	6770	8463	13540	16926	-	-	-	-	
			1.75	2.405	20.90	1254	1672	2090	4180	5224	8359	10449	-	-	-	-	
			2	3.142	16.00	960	1280	1600	3200	4000	6400	8000	-	-	-	-	
			2.5	4.909	10.24	614	819	1024	2048	2560	4096	5120	-	-	-	-	
			3	7.068	7.11	427	569	711	1422	1778	2844	3556	-	-	-	-	
			3.5	9.621	5.22	313	418	522	1045	1306	2090	2612	-	-	-	-	
			4	12.566	4.00	240	320	400	800	1000	1600	2000	-	-	-	-	
			4.5	15.904	3.16	190	253	316	632	790	1264	1580	-	-	-	-	
8	50.264	200 500	5	19.634	2.56	154	205	256	512	640	1024	1280	-	-	-	-	
			5.5	23.758	2.12	127	169	212	423	529	846	1058	-	-	-	-	
			1.75	2.405	32.65	1959	2612	3265	6531	8163	13061	-	-	-	-		
			2	3.142	25.00	1500	2000	2500	5000	6250	10000	-	-	-	-		
			2.5	4.909	16.00	960	1280	1600	3200	4000	6400	-	-	-	-		
			3	7.068	11.11	667	889	1111	2222	2778	4444	-	-	-	-		
			3.5	9.621	8.16	490	653	816	1633	2041	3265	-	-	-	-		
			4	12.566	6.25	375	500	625	1250	1563	2500	-	-	-	-		
			4.5	15.904	4.94	296	395	494	988	1235	1975	-	-	-	-		
			5	19.634	4.00	240	320	400	800	1000	1600	-	-	-	-		
10	78.538	200 400	5.5	23.758	3.31	198	264	331	661	827	1322	-	-	-	-		
			2	3.142	36.00	2160	2880	3600	7200	9000	14400	-	-	-	-		
			2.5	4.909	23.04	1382	1843	2304	4608	5760	9216	-	-	-	-		
			3	7.068	16.00	960	1280	1600	3200	4000	6400	-	-	-	-		
			3.5	9.621	11.76	705	940	1176	2351	2939	4702	-	-	-	-		
			4	12.566	9.00	540	720	900	1800	2250	3600	-	-	-	-		
			4.5	15.904	7.11	427	569	711	1422	1778	2844	-	-	-	-		
			5	19.634	5.76	346	461	576	1152	1440	2304	-	-	-	-		
			5.5	23.758	4.76	286	381	476	952	1190	1904	-	-	-	-		
			2.5	4.909	31.36	1882	2509	3136	6272	7840	12544	-	-	-	-		
12	113.094	200 400	3	7.068	21.78	1307	1742	2178	4356	5444	8711	-	-	-			
			3.5	9.621	16.00	960	1280	1600	3200	4000	6400	-	-	-			
			4	12.566	12.25	735	980	1225	2450	3063	4900	-	-	-			
			4.5	15.904	9.68	581	774	968	1936	2420	3872	-	-	-			
			5	19.634	7.84	470	627	784	1568	1960	3136	-	-	-			
			5.5	23.758	6.48	389	518	648	1296	1620	2592	-	-	-			
			14	153.934	200 400	2.5	4.909	31.36	1882	2509	3136	6272	7840	12544	-	-	-

**NOTE:** When output pressures are in the gray shaded area, the output pressure has exceeded the rating for the output cylinder and then Boosters NBS-5 THROUGH NBD-5 should not be used. For output pressures greater than 5000 PSI, please consult the factory.

**NOTE:** When output pressures are not shown, either output pressure has exceeded rating of output cylinder or input pressure has exceeded rating of input cylinder.

• = CL3 series not shown in this ratio combination.

# BOOSTER SELECTION CHART

NB-3 (3000 PSI)

INPUT CYLINDER				OUTPUT CYLINDER					BOOSTER RATIO	OUTPUT PRESSURE (PSI) AT INPUT PRESSURE OF										
BORE	AREA	MAXIMUM INPUT PRESSURE		BORE	AREA	MAXIMUM OUTPUT PRESSURE USING				60	80	100	200	250	400	500	750	900	950	1100
		A	L			A	L	H												
2-1/2	4.909	250	1100	1-1/2	1.767	250	1500	3000	2.78	167	222	278	556	695	1111	1389	2084	2500	2639	-
3-1/4	8.296	250	1350	1-1/2	1.767	250	1500	3000	4.69	282	376	469	939	1174	1878	2347	-	-	-	-
				2	3.142	250	1500	3000	2.64	158	211	264	528	660	1056	1320	1980	2376	2508	-
4	12.566	250	950	1-1/2	1.767	250	1500	3000	7.11	427	569	711	1422	1778	2845	-	-	-	-	-
				2	3.142	250	1500	3000	4.00	240	320	400	800	1000	1600	2000	3000	-	-	-
				2-1/2	4.909	250	1100	3000	2.56	154	205	256	512	640	1024	1280	1920	2304	2432	-
5	19.634	250	900	1-1/2	1.767	250	1500	3000	11.11	667	889	1111	2222	2778	-	-	-	-	-	-
				2	3.142	250	1500	3000	6.25	375	500	625	1250	1562	2500	-	-	-	-	-
				2-1/2	4.909	250	1100	3000	4.00	240	320	400	800	1000	1600	2000	3000	-	-	-
				3-1/4	8.296	250	1350	3000	2.37	142	189	237	473	592	947	1183	1775	2130	-	-
6	28.274	200	750	2	3.142	250	1500	3000	9.00	540	720	900	1800	2250	-	-	-	-	-	-
				2-1/2	4.909	250	1100	3000	5.76	346	461	576	1152	1440	2304	2880	-	-	-	-
				3-1/4	8.296	250	1350	3000	3.41	204	273	341	682	852	1363	1704	2556	-	-	-
				4	12.566	250	950	3000	2.25	135	180	225	450	563	900	1125	1688	-	-	-
8	50.264	200	500	2	3.142	250	1500	3000	16.00	960	1280	1600	-	-	-	-	-	-	-	-
				2-1/2	4.909	250	1100	3000	10.24	614	819	1024	2048	2560	-	-	-	-	-	-
				3-1/4	8.296	250	1350	3000	6.06	364	485	606	1212	1515	2424	-	-	-	-	-
				4	12.566	250	950	3000	4.00	240	320	400	800	1000	1600	2000	-	-	-	-
				5	19.634	250	900	3000	2.56	154	205	256	512	640	1024	1280	-	-	-	-
10	78.538	200	400	2-1/2	4.909	250	1100	3000	16.00	960	1280	1600	-	-	-	-	-	-	-	-
				3-1/4	8.296	250	1350	3000	9.47	568	757	947	1893	2367	-	-	-	-	-	
				4	12.566	250	950	3000	6.25	375	500	625	1250	1563	2500	-	-	-	-	
				5	19.634	250	900	3000	4.00	240	320	400	800	1000	1600	-	-	-	-	
				6	28.274	250	750	3000	2.78	167	222	278	556	694	1111	-	-	-	-	
12	113.094	200	400	3-1/4	8.296	250	1350	3000	13.63	818	1091	1363	2726	-	-	-	-	-	-	
				4	12.566	250	950	3000	9.00	540	720	900	1800	2250	-	-	-	-		
				5	19.634	250	900	3000	5.76	346	461	576	1152	1440	2304	-	-	-		
				6	28.274	250	750	3000	4.00	240	320	400	800	1000	1600	-	-	-		
				8	50.264	250	500	3000	2.25	135	180	225	450	563	900	-	-	-		
14	153.934	200	400	4	12.566	250	950	3000	12.25	735	980	1225	2450	-	-	-	-	-	-	
				5	19.634	250	900	3000	7.84	470	627	784	1568	1960	-	-	-			
				6	28.274	250	750	3000	5.44	327	436	544	1089	1361	2178	-	-	-		
				8	50.264	250	500	3000	3.06	184	245	306	613	766	1225	-	-			

**NOTE:** When output pressures are not shown, either output pressure has exceeded rating of 3000 PSI at output cylinder or input pressure has exceeded rating of input cylinder.

A = AIR

L = LOW PRESSURE HYDRAULIC

H = HIGH PRESSURE HYDRAULIC

## GENERAL INFORMATION

NOPAK air-oil tanks are used as a simple economical method to supply a make up source of oil to any hydraulic circuit. Mounting the tank in a vertical position above the circuit that is being supplied, automatically bleeds the entire circuit system. The air supply to the air over oil tank is supplied by the same shop air source that provides low pressure power to the booster. In addition, air-oil tanks offer a means of smooth hydraulic speed control.

### DESIGN FEATURES:

- Baffles on either end of the tank to reduce turbulence caused by rapid intake of air and discharge of oil causing aeration, whirlpooling and foaming.
- Replaceable sight gauge mounted in heads on the tank side. The transparent plastic sight tube clearly shows oil levels in the tank and is compatible with most hydraulic fluids.
- Large pipe ports enable the quick filling or draining of the tank. Aluminum heads are standard for tank diameters of 3-1/4" through 8". Otherwise steel Class 6 inventoried stock of 3-1/4" diameter through 14" diameters modified for added ports plus aluminum tubes are standard stock.

### NOTE:

Tanks are also available with glass wound filament fiberglass tubing. Because it is translucent, it provides a visual oil level indication. This eliminates the use of a sight gauge. Fiberglass tubing has the highest strength to weight ratio commercially available. It has a higher resistance for high impact and dents than brass or aluminum tubing. Corrosion resistant to a wide range of chemicals, acids, high moisture and other severe conditions make for a trouble-free operation in most environments. NOPAK can economically supply you with either tank depending on your choice preference or specification.

## HOW TO SELECT THE CORRECT SIZED AIR-OIL TANK

- 1 Determine the bore diameter and stroke of the work cylinder.
- 2 Calculate the cubic inch oil displacement of work cylinder by multiplying the piston square inch area times the stroke in inches. (Use Class 6 Section, page 113, "TABLE B - VOLUME OF OIL PER 12" OF STROKE" for piston square inch area for ready reference.) Your determination will result in the cubic inch displacement volume requirement needed to select an air-oil tank.

### EXAMPLE:

Work cylinder has a 4" diameter bore with 15" long stroke.  
From the Class 6 Section, page 113:

$$12.56 \text{ sq. in. area } 4" \text{ bore} \\ \times 15" \text{ stroke length} \\ \hline 188.4 \text{ cu. in. displacement volume needed.}$$

See the tank selector chart below to select proper choice. Select a bore-height combination that has a capacity closest to, but larger than 188.4 cu. in. Your options are the 4" diameter bore with a 21" long tank length or the 5" bore with a 14" tank length or a 6" bore with an 11" tank length.

Economics recommends that your selection be the smaller 4" diameter bore with the 21" long tank length. This of course is predicated on available space. The smaller bore tanks are generally less costly than larger bores. Exceptions to this are the booster-tank combination, which then makes your selection to be that the tank diameter be the same diameter as the booster. Next selection would be the type of mount applicable to your requirements. See the chart on opposite page for selection and dimensions. NOPAK offers Models H, S, T, TB, and AP as a standard. However, other mounting styles can be selected from the Class 6 Section. When boosters and air-oil tanks are ordered, specify whether air-oil tanks should be separate or integral. It is assumed that air-oil tanks are to be separate unless specified.

Please consult the NOPAK Sales office or your nearest NOPAK representative for additional information.

## TANK SELECTOR CHART

TANK BORE (INCHES)	TANK VOLUME IN CUBIC INCHES																				
	TL - TANK LENGTH IN INCHES																				
	5	6	7	8	9	10	11	12	13	14	15	16	17	18	19	20	21	22	23	24	25
3-1/4	21	25	32	35	44	51	58	66	73	80	88	95	102	109	116	124	131	139	146	153	160
4	31	38	48	56	67	78	88	100	111	122	133	144	155	166	176	188	199	210	221	232	242
5	49	59	76	88	105	122	137	157	174	191	208	225	243	260	273	294	311	328	346	363	378
6	70	85	109	127	152	176	198	226	250	275	300	325	349	374	396	424	448	473	498	523	544
8	126	151	195	226	270	314	352	402	446	490	534	578	622	666	704	754	798	841	885	929	968
10	196	236	304	353	422	490	550	628	697	765	834	903	971	1040	1100	1178	1246	1315	1384	1453	1512
12	283	339	438	509	607	706	792	904	1003	1102	1201	1300	1399	1498	1583	1696	1795	1894	1993	2092	2177
14	385	462	597	692	827	962	1078	1231	1366	1500	1635	1770	1905	2039	2155	2309	2443	2578	2713	2847	2963
Fluid Working Height In.	2-1/2	3	3-7/8	4-1/2	5-3/8	6-1/4	7	8	8-7/8	9-3/4	10-3/8	11-1/2	12-3/8	13-1/4	14	15	15-7/8	16-3/4	17-5/8	18-1/2	19-1/4

## MODEL H

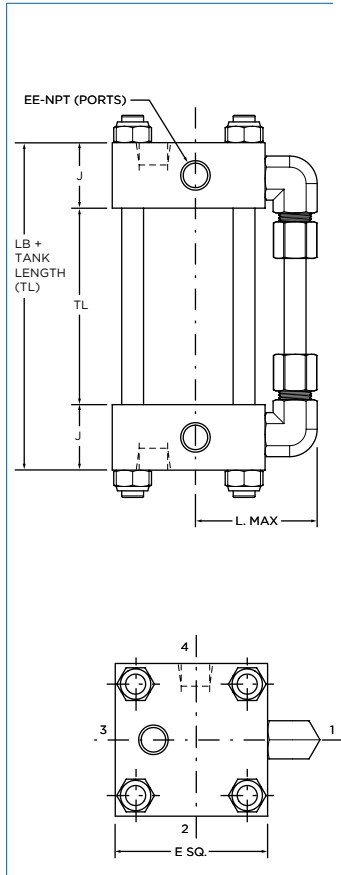

## MODEL T-TB (NFPA STD. STYLE MX1 & MX2)

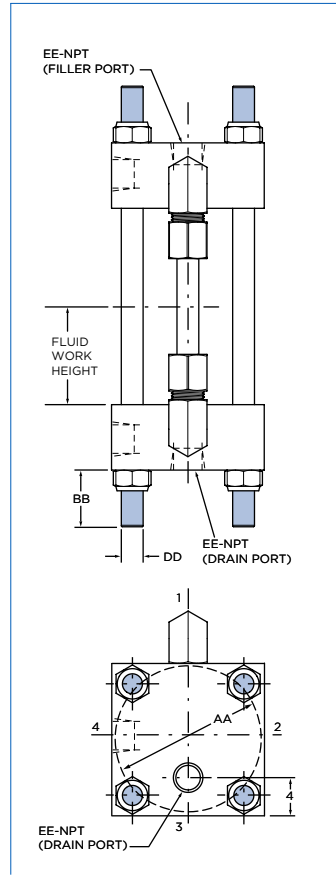

## MODEL S (NFPA STD. STYLE MS4)

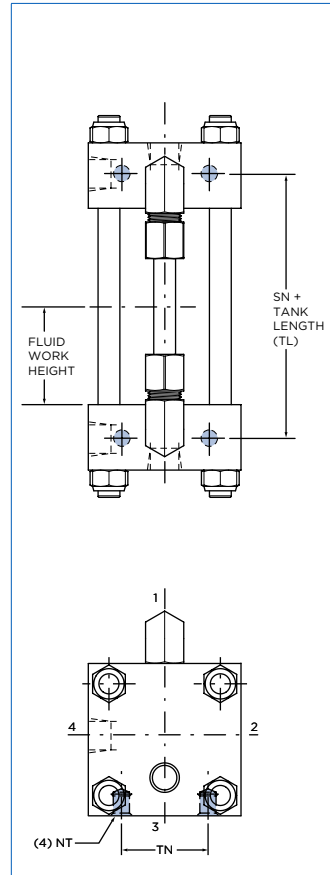

## MODEL AP (NFPA STD. STYLE MS1)

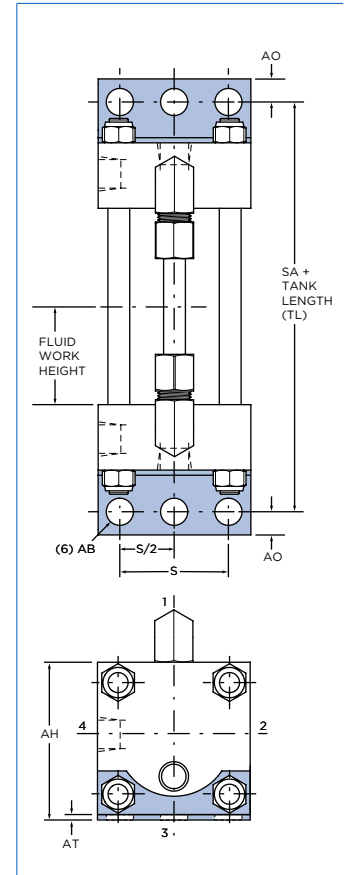

### Table 1

• = Dimension refers to bolt diameter.

TANK BORE (INCHES)	E	J	U	S	L	AA	AB•	AT	AH	AO	BB	DD	EE	LB	NT	SA	SN	TN
3-1/4	3-3/4	1-1/4	1-3/8	2-3/4	3-1/4	4.00	1/2	2	1/2	1/8	1-3/8	7/16-20	1/2	2-1/2	1/2-13	5	1-3/8	1-1/2
4	4-1/2	1-1/4	1-5/8	3-1/2	3-5/8	4.75	1/2	2-1/4	1/2	1/8	1-3/8	7/16-20	1/2	2-1/2	1/2-13	5	1-3/8	2-1/16
5	5-1/2	1-1/4	2	4-1/4	4-1/8	5.80	5/8	2-3/4	5/8	3/16	1-3/4	1/2-20	1/2	2-1/2	5/8-11	5-1/4	1-3/8	2-11/16
6	6-1/2	1-1/2	2-1/4	5-1/4	4-5/8	6.90	3/4	3-1/4	5/8	3/16	1-3/4	9/16-18	3/4	3	3/4-10	5-3/4	1-5/8	3-1/4
8	8-1/2	1-1/2	3	7-1/8	5-5/8	9.10	3/4	4-1/4	11/16	1/4	2-1/4	5/8-18	3/4	3	3/4-10	6-5/8	1-5/8	4-1/2
10	10-5/8	2	3-1/4	8-7/8	6-3/4	11.30	1	5-5/16	7/8	1/4	2-5/8	3/4-16	1	4	1-8	8-1/4	2	5-1/2
12	12-3/4	2	3-3/4	11	7-3/4	13.31	1	6-3/8	7/8	3/8	2-11/16	3/4-16	1	4	1-8	8-1/4	2	7-1/4
14	14-3/4	2-1/4	3-7/8	12-5/8	8-3/4	15.40	1-1/4	7-3/8	1-1/16	3/8	3-3/16	7/8-14	1-1/4	4-1/2	1-1/4-7	9-3/8	2-3/8	8-3/8



# Terms and Conditions of Sale

---

## TERMS AND CONDITIONS OF SALE

Effective January 1, 2015

**These Galland Henning NOPAK, Inc. ("Seller") Terms and Conditions of Sale shall govern all sales and all orders placed by buyer ("Buyer") for goods or products (collectively, "Products") from Seller.**

Seller may, at its option and without liability, cancel all or any portion of Buyer's order and/or extend any date upon which any performance hereunder is due.

- 1 **ACCEPTANCE; CONTRARY TERMS; ENTIRE AGREEMENT.** All orders for Products are subject to acceptance by Seller at its offices in Franklin, Wisconsin. Seller's written price quotation, if any ("Seller's Quotation") and these Terms and Conditions of Sale are intended by the parties to be the complete and exclusive agreement of the parties with respect to the subject matter hereof and supersede all prior understandings, representations, warranties or agreements between the parties, whether written or oral. BUYER'S ORDERS ARE ACCEPTED ONLY ON THE TERMS AND CONDITIONS CONTAINED HEREIN AND THE PROVISIONS OF ANY PURCHASE ORDER OR OTHER WRITING WHICH ARE INCONSISTENT HERewith SHALL NOT CONSTITUTE PART OF THESE TERMS AND CONDITIONS OF SALE. SELLER'S ACCEPTANCE OF BUYER'S ORDER IS SUBJECT TO AND CONDITIONED ON BUYER'S ASSENT TO THESE TERMS AND CONDITIONS OF SALE.
- 2 **PRICE AND DELIVERY:** Prices shall be as set forth on Seller's Quotations, provided however, that prices may be adjusted by Seller without notice to conform to prices in effect at the time of shipment. Unless otherwise specified by Seller in writing, all prices are F.O.B. Seller's plant. All Seller's Quotations automatically expire thirty (30) calendar days from date of issuance unless communicated otherwise by Seller. Unless otherwise specified by Seller in writing, prices stated on Seller's Quotations do not include any sales, use or value-added taxes, or any other taxes, charges or duties applicable to the sale of Products, which taxes, charges and duties (including any interest and penalties) shall be the sole responsibility of Buyer. Buyer shall provide Seller with tax exemption certificates if requested by Seller. Unless otherwise agreed to by the parties in writing, all Products are shipped F.O.B Seller's plant. Risk of loss shall pass to Buyer at the time the Products are delivered to a carrier at Seller's plant and Buyer shall be solely responsible for procuring commercially reasonable insurance coverage for the Products after such delivery for the benefit of Seller and Buyer. Title to the Products will remain with Seller until full payment (including deferred payments) is received by Seller. All freight, storage, insurance or other fees or charges (including, without limitation, any sales, use or value-added taxes and import duties on the Products, if any) shall be paid by Buyer and if advanced by Seller, shall be added to Seller's invoice and payable together with payment for the Products purchased. Seller will package the Products in a commercially reasonable manner acceptable to commercial carriers. All risk of loss relating to any goods or products not manufactured by Seller which are delivered by Buyer to Seller shall at all times remain the sole and exclusive responsibility of Buyer.
- 3 **DELAYS; PERFORMANCE:** Seller does not guarantee arrival of shipment(s) at a particular time or date under any circumstances. Seller shall have no liability whatsoever for any failure or delay in shipment or other nonperformance if shipment or performance is rendered impossible, impracticable or unreasonably burdensome by any event, whether or not foreseen or foreseeable, brought about by any cause other than the willful conduct of Seller, including, without limitation, accidents; breakdowns; riots; war; terrorism; interruptions in or failures of sources or subcontractors to supply materials or equipment; failures in manufacturing processes or equipment; strikes, labor or transportation problems; fires, explosions or other acts of God; or orders, contracts, priorities, directives, requisitions or requests of the federal or state governments, whether or not voluntarily assumed. In the event of any such failure or delay in shipment or other nonperformance,
- 4 **PAYMENT TERMS:** Unless otherwise agreed to in writing by the parties, all invoices for Products shall be paid net 30 days and shall be payable in U.S. Dollars. If all Product(s) from an order are not shipped on the same date, pro rata invoices shall be rendered for such partial shipments. If shipment of any Product(s) (and/or materials or parts thereof) is delayed, either directly or indirectly by the Buyer, the date of completion of the Product(s) shall be deemed as the date of shipment and invoice. No orders by Buyer can be cancelled or returned without the written consent of Seller (in which case Buyer shall reimburse Seller for its reasonable costs associated with such cancelled or returned Products). OUTSTANDING BALANCES NOT PAID WHEN DUE SHALL BE SUBJECT TO A DELINQUENCY CHARGE ACCRUING AT THE RATE OF THE LOWER OF 1.5% PER MONTH OR THE MAXIMUM INTEREST RATE ALLOWABLE UNDER LAW. Buyer shall also pay Seller any collection fees and reasonable attorneys' fees incurred by Seller in collecting payment of the purchase prices or any other amounts for which Buyer is liable under the terms and conditions hereof. Seller shall have the right to cancel all or any portion of Buyer's order in the event Buyer has outstanding balances which are delinquent by 15 days or more.
- 5 **EXCLUSIVE WARRANTY:** Seller warrants to the Buyer that the Products sold are to be free from defects in material and workmanship for (i) with respect to Products that contain perishable elastomers (e.g. rubber), a period of six (6) months from the date of shipment, (ii) with respect to the paint and finish of any Products, a period of six (6) months from the date of shipment and (iii) for all other Products (excluding paint and finish of Products), a period of five (5) years from the date of shipment, subject to the terms and limitations of the exclusive warranty and remedies described herein. THIS FOREGOING WARRANTY IS EXCLUSIVE AND IN LIEU OF ANY OTHER WARRANTY, EXPRESS OR IMPLIED, INCLUDING, BUT NOT LIMITED TO, ANY IMPLIED WARRANTY OF MERCHANTABILITY OR FITNESS FOR A PARTICULAR PURPOSE. SELLER NEITHER ASSUMES (NOR HAS AUTHORIZED ANY PERSON TO ASSUME) ANY OTHER WARRANTY OR LIABILITY IN CONNECTION WITH SELLER'S PRODUCTS. IF BUYER'S ORDER IS FOR PRODUCTS WHICH CONTAIN COMPONENTS MANUFACTURED BY A PARTY OTHER THAN SELLER, BUYER ACKNOWLEDGES THAT SELLER IS NOT THE MANUFACTURER OF SUCH COMPONENTS AND AGREES THAT ALL SUCH COMPONENTS ARE NOT COVERED BY THE WARRANTY PROVIDED HEREIN AND ARE WARRANTED ONLY TO THE EXTENT OF THE MANUFACTURER'S EXPRESS WARRANTIES TO SELLER, WHICH SELLER SHALL PROVIDE TO BUYER AT BUYER'S REQUEST. SELLER'S WARRANTIES CONTAINED IN THESE TERMS AND CONDITIONS SHALL AUTOMATICALLY BECOME NULL AND VOID IN THE EVENT OF (I) INSTALLATION OF ANY PARTS NOT SUPPLIED OR AUTHORIZED IN WRITING BY SELLER, (II) MODIFICATION OF A PRODUCT, OR (III) IMPROPER OR UNAUTHORIZED REPAIRS ARE MADE TO A PRODUCT. THE FAILURE OF BUYER TO PAY THE FULL PURCHASE PRICE FOR ANY PRODUCT ACCORDING TO THESE TERMS AND CONDITIONS OF SALE OR ANY OTHER OUTSTANDING BALANCE DUE FOR A PRIOR, CURRENT OR FUTURE OBLIGATION OWED TO SELLER SHALL AUTOMATICALLY VOID ANY OF SELLER'S WARRANTY OBLIGATIONS CONTAINED HEREIN.
- 6 **LIMITATION OF REMEDIES AND DAMAGES:** Buyer shall provide Seller with written notice of any alleged defects in material or workmanship that arise under proper and normal use of the Products during the warranty period set forth in Section 5, above.



Seller shall arrange for inspection of such Products within fifteen (15) days of its receipt of such notice. Before the end of such fifteen (15) day period, Seller shall advise Buyer whether Seller will, at its sole option, repair or replace Products found to be defective or credit Buyer for the same. Seller shall not be liable for damage to any Product resulting from (i) improper installation or operation, (ii) installation of any parts not supplied or authorized by Seller, (iii) modification of such Product, (iv) improper or unauthorized repairs, (v) improper storage or handling of such Product, (vi) negligent or willful misconduct of Buyer or (vii) Buyer's designs, change orders or changes in specifications. No Products shall be returned to Seller without its prior written consent. EXCEPT AS OTHERWISE EXPRESSLY PROVIDED HEREIN, SELLER WILL NOT BE LIABLE TO BUYER OR ANY THIRD PARTY FOR ANY CONSEQUENTIAL, INCIDENTAL, INDIRECT, PUNITIVE, OR SPECIAL DAMAGES ARISING OUT OF OR RELATING TO THESE TERMS AND CONDITIONS OF SALE OR THE PERFORMANCE OR BREACH HEREOF, INCLUDING, BUT NOT LIMITED TO, LABOR COSTS, LOSS OF USE, LOST REVENUES, LOST PROFITS, DAMAGE TO ASSOCIATED EQUIPMENT OR FACILITIES, COSTS OF REPLACEMENT POWER, COSTS ASSOCIATED WITH DOWNTIME, AND ANY SIMILAR LOSSES, COSTS OR DAMAGES, AND REGARDLESS OF HOWEVER CAUSED, WHETHER BASED ON CONTRACT, TORT, OR ANY OTHER LEGAL THEORY AND IN NO EVENT SHALL SELLER'S LIABILITY WITH RESPECT TO A BREACH OF THE LIMITED WARRANTY PROVIDED BY THESE TERMS AND CONDITIONS EXCEED THE PURCHASE PRICE PAID BY BUYER FOR THE PRODUCT(S) IN QUESTION.

- 7 **INTELLECTUAL PROPERTY:** Buyer represents and warrants that Buyer has all right, title and interest to and in, or has been granted a license to use, any patent, trademark and/or other intellectual property that Buyer has or will request Seller to affix to, or use in the production of an any Product supplied hereunder. Buyer further represents and warrants that the use or omission of any designs, devices, or words, including any wording required by any Federal, State or local laws or ordinances which Buyer may from time to time order incorporated in or imprinted or placed on the Products is in conformance with all applicable laws and does not infringe on any third party's intellectual property rights (regardless of whether or not Seller consulted thereon or performed design work or other special services in connection therewith).
- 8 **CLAIMS AND MODIFICATIONS:** Buyer shall have ten (10) days after receipt of the Products to inspect and make any claims for error in design and specifications. Failure to make such a claim and reject Products within such period shall constitute an irrevocable acceptance of the Products and an admission that the Products fully comply with design and specifications. Seller reserves the right to accept or reject any such claim in whole or part. Replacement of defective Products or repayment of the purchase price for non-conforming Products shall be made only upon return thereof after inspection by Seller and Buyer's compliance with written shipping instructions from Seller. Any claims for loss or damage during transit must be prosecuted by Buyer solely against the carrier and/or insurer. Buyer may not make any changes to Buyer's order without the prior written consent of Seller. Any price variation from any such changes shall become effective immediately upon the acceptance of such changes by Seller.
- 9 **INDEMNIFICATION:** Buyer shall indemnify and hold Seller and each of its officers, directors, employees, shareholders, affiliates, agents, representatives, successors and assigns harmless from and against any and all claims, actions, demands, legal proceedings, judgments, settlements, sums, costs, liabilities, losses, obligations, damages, penalties, fines, costs and other expenses (including, but

not limited to, reasonable attorneys' fees) relating to, arising out of or resulting from (i) Buyer's use of any Product, including, without limitation, any third party claims for personal injury or property damage resulting from Buyer's negligence or willful misconduct, (ii) any act by Buyer or its employees, agents or representatives, which causes the warranties contained in these terms and conditions to be null and void, (iii) any infringement or claim of infringement of any proprietary right of a third party by reason of Buyer's plans, specifications or the production, use or sale of any Product purchased by Buyer and (iv) Buyer's violation or alleged violation of any Federal, state, county or local laws or regulations, including, without limitation, the laws and regulations governing product safety, labeling, packaging and labor practices. If any claim should be asserted or action commenced against Seller for which Seller is entitled to indemnification hereunder, Buyer shall, upon Seller's demand, promptly undertake the defense of such claim or action, employing counsel satisfactory to Seller or, alternatively, Seller may elect to defend the same on its own behalf. In either case, Buyer will, upon demand, pay all reasonable attorney's fees and other costs or expenses incurred by Seller in connection with such defense, including, but not limited to, any judgment or award resulting from any such claim or action and any settlement paid by Seller with Buyer's consent.

- 10 **ASSIGNMENT:** Buyer may not assign any of its rights, duties or obligations under these Terms and Conditions of Sale without Seller's prior written consent. Any attempted assignment without Seller's written consent, even if by operation of law, shall be null and void.
- 11 **CONTROLLING LAW; VENUE:** These Terms and Conditions of Sale and the interpretation, construction and enforcement thereof and all provisions, suits and special proceedings thereunder shall be governed by the internal laws of the State of Wisconsin, without regard to rules of construction concerning the drafter thereof and without regard to conflicts of law principles. Buyer (i) consents to submit to the exclusive jurisdiction of the state and federal courts located in Milwaukee County, Wisconsin for the resolution of any dispute between the parties concerning any Products or these Terms and Conditions of Sale; (ii) agrees not to commence any such proceeding except in such courts; and (iii) waives any objection to the laying of venue of any such proceeding in the state or federal courts located in Milwaukee County, Wisconsin.
- 12 **INVALIDITY; UNENFORCEABILITY:** In the event that any provision of these Terms and Conditions of Sale is found invalid or unenforceable, whether in whole or in part, for any reason, such provision shall be changed and interpreted so as to best accomplish the objectives of such provision within the limits of applicable law or applicable court decisions. The invalidity or unenforceability of any such provision or part of such provision will not affect the validity or enforceability of the remaining terms and conditions hereof.
- 13 **WAIVER:** The failure of Seller or Buyer, at any time, to require the performance of any obligation or to assert a right contained herein will not affect either party's right to require such performance or assert such right at any time thereafter; nor shall the waiver of any right or obligation be construed in any way as a waiver of any succeeding breach.



**GALLAND  
HENNING  
NOPAK**

Engineering Solutions  
Since 1887

10179 S. 57th Street; Franklin, WI 53132  
p 414.645.6000 | f 414.645.6048  
www.NOPAK.com | sales@NOPAK.com