

# Class 3

High Pressure Square-Head Cylinders

---



## OPTIONS

### BORE SIZE SELECTION

Unlike air applications, the output force of a cylinder for hydraulic service need be only slightly greater than the required force. Hydraulic cylinder speed is dependent directly on the relationship of supply flow rate to cylinder volume. Force tables to aid in cylinder sizing are on page 63.

### MOUNTINGS

Select the cylinder mounting which will keep the line of force as close as possible to the centerline of the piston rod and free of misalignment. This will maximize seal and bearing life.

## CUSTOM MODIFICATIONS

### STOP TUBES

In long cylinders used on push applications, internal stop tubes are installed to prevent excessive bearing wear. They are located between the piston and rod end head. See page 64 for instructions.

### OVERSIZE RODS

For long, push stroke cylinders, oversize rods may be required. See page 64 for instructions.

### DOUBLE ROD END

NOPAK Class 3 cylinders when ordered as double rod end are designated by prefixing the model with the letter "X." Mounting dimensions may vary from standard because two rod end heads are used. See page 54 through page 57.

### CUSHIONS

NOPAK Class 3 cylinders are available with adjustable cushions on either or both ends, or non-cushion. The purpose of a cushion is to slow up piston speed at the end of the stroke, eliminating shock. The mass to be cushioned should be limited to one-half the cylinder force unless other provisions are made for deceleration or special cushioning.

### PISTON ROD EXTENSION AND ROD THREADING

Longer than standard piston rod extensions may be required to accommodate load fastening. Depending upon the details of rod engagement to load, special threading or rod end configuration may be required.

### CYLINDER PORTS

Ports are offered as NPTF, SAE O-ring or SAE Flange Type. NPTF ports standard for 1-1/2" thru 8" diameter cylinder bores. To increase cylinder speed, increased fluid volume is necessary. This can be done by using enlarged or additional ports.

## HOW TO ORDER

**You can help ensure prompt processing of your order by including all of the following requested information:**

1. Quantity required.
2. Specify Class 3.
3. Bore or cylinder diameter size.
4. Stroke length in inches.
5. Type of mounting (NOPAK model or NFPA style.)
6. Type of cushioning:  
 NN = non-cushioned  
 NA = cushioned blind end  
 AN = cushioned rod end  
 AA = cushioned both ends
7. Piston rod diameter and type of rod threading - specify Type 1, 3, 4, 5, 6 or 7. See page 58.

### Also Specify:

1. Position of cylinder ports and cushion adjustment screw, if other than standard. Standard positions are:  
 Cylinder ports - position 1  
 Ball check - position 2  
 Cushion adjustment - position 4
2. Extreme high or low operating or ambient temperatures.
3. Extreme operating pressures.
4. Type of operating fluid if other than standard petroleum base oil.
5. Any unusual operating conditions.

## ORDERING CODE EXAMPLE

**CL3 - 4 x 18 - A - Δ Δ - 1.75 - 4 - OPT**

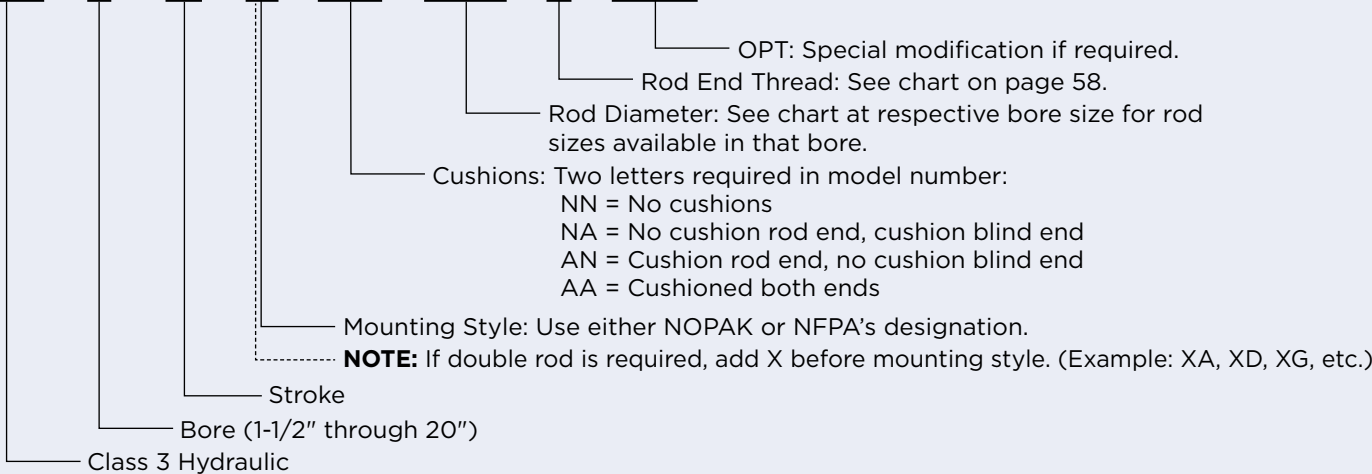

**MODEL A (NFPA STD. MS2)** ▲

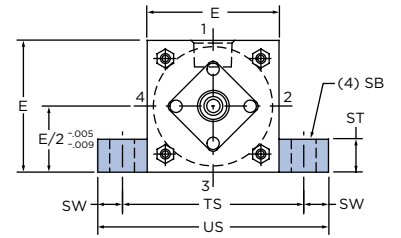
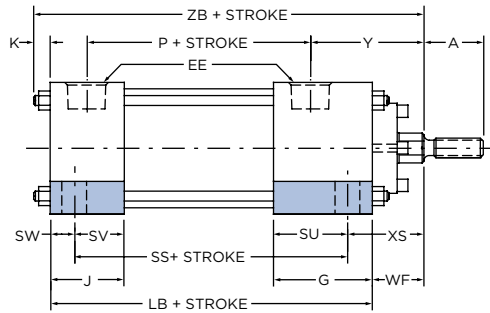
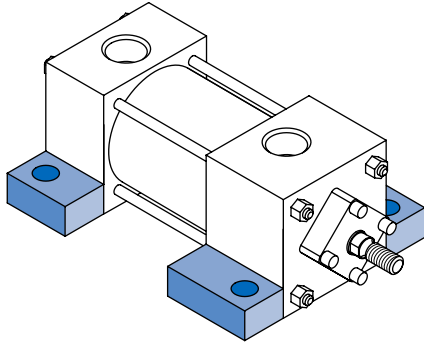

**MODEL B (NFPA STD. MS3)** ▲

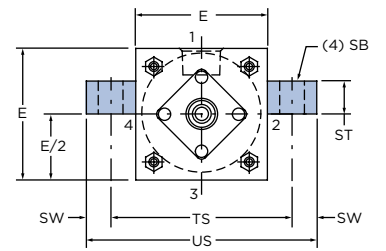
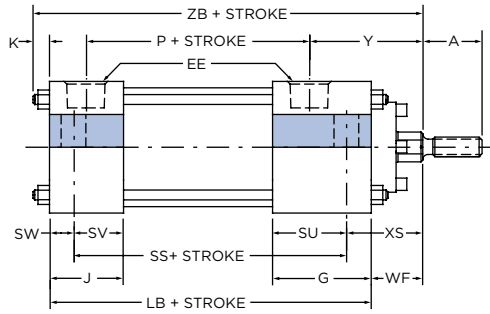
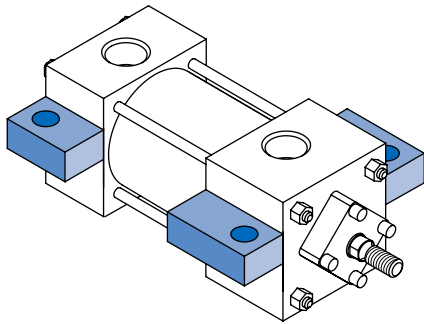

**MODEL S (NFPA STD. MS4)**

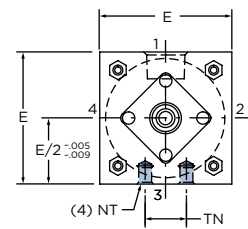
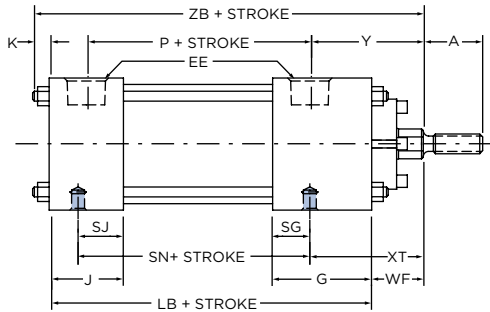
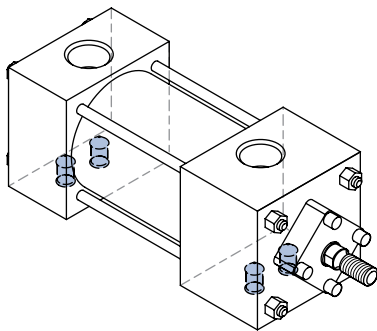

▲ = See Table A on page 55 for bore and rod combinations using head plates with threaded bronze glands.

# SIDE AND LUG MOUNT CYLINDERS

1-1/2" THROUGH 7" DIAMETER

**Table 1** These dimensions are constant regardless of rod diameter or stroke.

For double rod end cylinders Model A and B: subtract dimensions SV from SU and add to dimension SS + Stroke. See pages 54-57.  
Double rod end models are designated by letter "X" preceding the model identification. See page 54.

• = Dimensions refer to bolt diameter.

BORE DIA.	E	G	J	K	EE	NT	SB•	SG	SJ	ST	SU	SV	SW	TN	TS	US
1-1/2	2-1/2	1-3/4	1-1/2	1/2	1/2	3/8-16	3/8	3/4	3/4	1/2	1-3/8	1-1/8	3/8	3/4	3-1/4	4
2	3	1-3/4	1-1/2	1/2	1/2	1/2-13	1/2	3/4	3/4	3/4	1-1/4	1	1/2	15/16	4	5
2-1/2	3-1/2	1-3/4	1-1/2	5/8	1/2	5/8-11	3/4	3/4	3/4	1	1-1/16	13/16	11/16	1-5/16	4-7/8	6-1/4
3-1/4	4-1/2	2-1/4	1-3/4	3/4	3/4	3/4-10	3/4	1-1/8	7/8	1	1-9/16	1-1/16	11/16	1-1/2	5-7/8	7-1/4
4	5	2-1/4	1-3/4	3/4	3/4	1-8	1	1-1/8	7/8	1-1/4	1-3/8	7/8	7/8	2-1/16	6-3/4	8-1/2
5	6-1/2	2-1/4	1-3/4	1	3/4	1-8	1	1-1/8	7/8	1-1/4	1-3/8	7/8	7/8	2-15/16	8-1/4	10
6	7-1/2	2-1/2	2-1/4	1-1/8	1	1-1/4-7	1-1/4	1-1/4	1-1/4	1-1/2	1-3/8	1-1/8	1-1/8	3-5/16	9-3/4	12
7	8-1/2	2-3/4	2-3/4	1-1/8	1-1/4	1-1/2-6	1-1/2	1-13/16	1-11/16	1-3/4	1-3/8	1-3/8	1-3/8	3-3/4	11-1/4	14

**Table 2** The dimensions given on this table are affected by the piston rod diameter and the stroke.

For double rod end cylinders Model S: in place of dimension SN + stroke, multiply dimension XT times 2 and to this total add the cylinder stroke. From this figure, subtract the ZM + double stroke. See pages 54-57.

• = For piston rod dimensions see page 58.

BORE DIA.	ROD MM•	A	P	Y	LB	SN	SS	WF	XS	XT	ZB
1-1/2	5/8	3/4	2-3/4	2-1/16	4-5/8	2-7/8	3-7/8	1	1-3/8	2	6-1/8
	1	1-1/8	2-3/4	2-7/16	4-5/8	-	3-7/8	1-3/8	1-3/4	-	6-1/2
2	1	1-1/8	2-3/4	2-7/16	4-5/8	2-7/8	3-5/8	1-3/8	1-7/8	2-3/8	6-1/2
	1-3/8	1-5/8	2-3/4	2-11/16	4-5/8	-	3-5/8	1-5/8	2-1/8	-	6-3/4
2-1/2	1	1-1/8	2-7/8	2-7/16	4-3/4	3	3-3/8	1-3/8	2-1/16	2-3/8	6-3/4
	1-3/8	1-5/8	2-7/8	2-11/16	4-3/4	-	3-3/8	1-5/8	2-5/16	-	7
	1-3/4	2	2-7/8	2-15/16	4-3/4	-	3-3/8	1-7/8	2-9/16	-	7-1/4
3-1/4	1-3/8	1-5/8	3-1/4	3	5-1/2	3-1/2	4-1/8	1-5/8	2-5/16	2-3/4	7-7/8
	1-3/4	2	3-1/4	3-1/4	5-1/2	-	4-1/8	1-7/8	2-9/16	-	8-1/8
	2	2-1/4	3-1/4	3-3/8	5-1/2	-	4-1/8	2	2-11/16	-	8-1/4
4	1-3/4	2	3-1/2	3-1/4	5-3/4	3-3/4	4	1-7/8	2-3/4	3	8-3/8
	2	2-1/4	3-1/2	3-3/8	5-3/4	-	4	2	2-7/8	-	8-1/2
	2-1/2	3	3-1/2	3-5/8	5-3/4	-	4	2-1/4	3-1/8	-	8-3/4
5	2	2-1/4	4	3-3/8	6-1/4	4-1/4	4-1/2	2	2-7/8	3-1/8	9-1/4
	2-1/2	3	4	3-5/8	6-1/4	-	4-1/2	2-1/4	3-1/8	-	9-1/2
	3	3-1/2	4	3-5/8	6-1/4	-	4-1/2	2-1/4	3-1/8	-	9-1/2
	3-1/2	3-1/2	4	3-5/8	6-1/4	-	4-1/2	2-1/4	3-1/8	-	9-1/2
6	2-1/2	3	4-5/8	3-3/4	7-3/8	5-1/8	5-1/8	2-1/4	3-3/8	3-1/2	10-3/4
	3	3-1/2	4-5/8	3-3/4	7-3/8	-	5-1/8	2-1/4	3-3/8	-	10-3/4
	3-1/2	3-1/2	4-5/8	3-3/4	7-3/8	-	5-1/8	2-1/4	3-3/8	-	10-3/4
	4	4	4-5/8	3-3/4	7-3/8	-	5-1/8	2-1/4	3-3/8	-	10-3/4
7	3	3-1/2	5-3/8	3-13/16	8-1/2	5-7/8	5-3/4	2-1/4	3-5/8	3-13/16	11-7/8
	3-1/2	3-1/2	5-3/8	3-13/16	8-1/2	-	5-3/4	2-1/4	3-5/8	-	11-7/8
	4	4	5-3/8	3-13/16	8-1/2	-	5-3/4	2-1/4	3-5/8	-	11-7/8
	4-1/2	4-1/2	5-3/8	3-13/16	8-1/2	-	5-3/4	2-1/4	3-5/8	-	11-7/8
	5	5	5-3/8	3-13/16	8-1/2	-	5-3/4	2-1/4	3-5/8	-	11-7/8

**MODEL A** (NFPA STD. MS2) 8" THROUGH 14" DIAMETER BORE

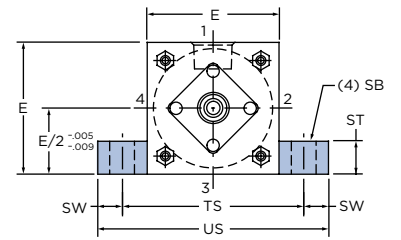
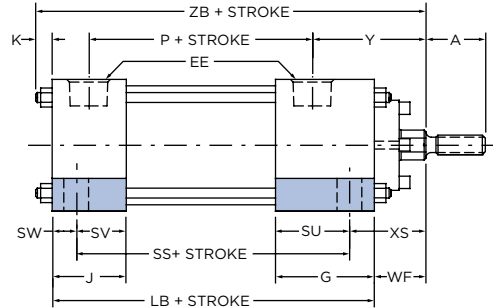
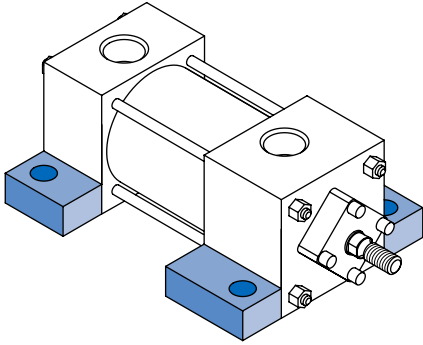

**MODEL B** (NFPA STD. MS3) 8" THROUGH 20" DIAMETER BORE

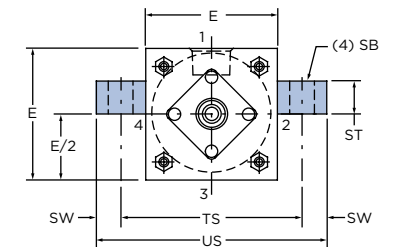
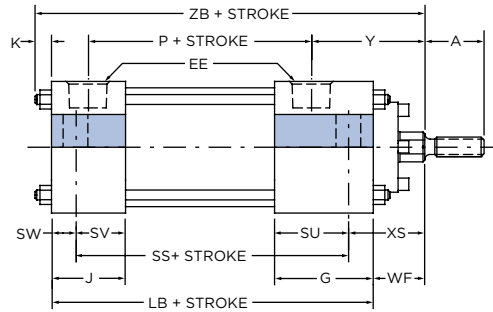
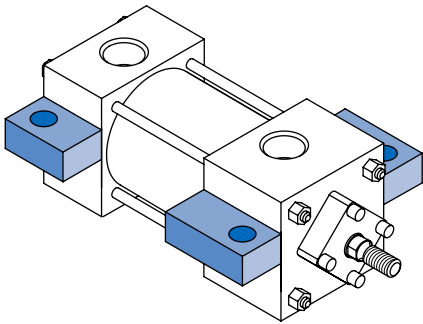

**MODEL S** (NFPA STD. MS4) 8" DIAMETER BORE

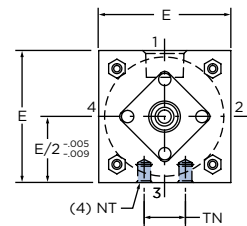
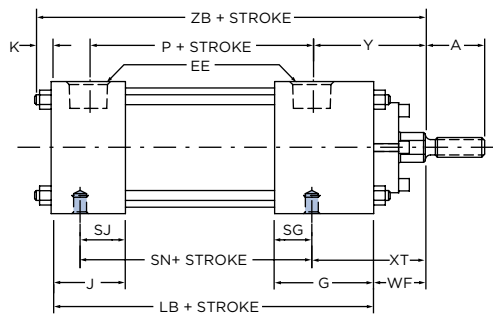
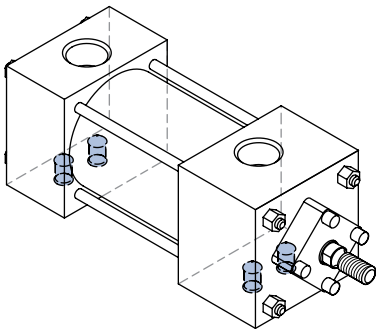

**NOTE:** This model available in small rod only.

# SIDE AND LUG MOUNT CYLINDERS

8" THROUGH 20" DIAMETER

**Table 1** These dimensions are constant regardless of rod diameter or stroke.

For double rod end cylinders Model A and B: subtract dimension SV from SU and add to dimension SS + stroke. See pages 54-57. Double rod end models are designated by letter "X" preceding the model identification. See page 54.

• = Dimensions refer to bolt diameter.

BORE DIA.	E	G	J	K	EE	NT	SB•	SG	SJ	ST	SU	SV	SW	TN	TS	US
8	9-1/2	3	3	1-3/8	1-1/2	1-1/2-6	1-1/2	1-5/16	1-13/16	1-3/4	1-5/8	1-5/8	1-3/8	4-1/4	12-1/4	15
10	12-5/8	3-11/16	3-11/16	1-1/8	2	-	1-1/2	-	-	2-1/4	2-1/16	2-1/16	1-5/8	-	15-7/8	19-1/8
12	14-7/8	4-7/16	4-7/16	1-1/8	2-1/2	-	1-1/2	-	-	3	2-7/16	2-7/16	2	-	18-7/8	22-7/8
14	17-1/4	4-7/8	4-7/8	1-7/16	2-1/2	-	2-1/4	-	-	4	2-5/8	2-5/8	2-1/4	-	21-3/4	26-1/4
16	19-1/4	5-7/8	5-7/8	1-7/16	3	-	2-1/2	-	-	4-1/2	3-1/8	3-1/8	2-1/2	-	24-1/4	29-1/4
18	22	6-7/8	6-7/8	1-7/16	3	-	2-3/4	-	-	5-1/4	3-5/8	3-5/8	2-3/4	-	27-1/2	33
20	23-5/8	7-7/8	7-7/8	1-7/16	3	-	3	-	-	6-1/2	4	4	3-1/4	-	30-1/8	36-5/8

**Table 2** The dimensions given on this table are affected by the piston rod diameter and the stroke.

For double rod end cylinders Model S: in place of dimension SN + stroke, multiply dimension XT times 2 and to this total add the cylinder stroke. From this figure, subtract the ZM + double stroke. See pages 54-57.

• = For piston rod dimensions see page 58.

BORE DIA.	ROD MM•	A	P	Y	LB	SN	SS	WF	XS	XT	ZB
8	3-1/2	3-1/2	6	4	9-1/2	6-5/8	6-3/4	2-1/4	3-5/8	3-15/16	13-1/8
	4	4	6	4	9-1/2	-	6-3/4	2-1/4	3-5/8	-	13-1/8
	4-1/2	4-1/2	6	4	9-1/2	-	6-3/4	2-1/4	3-5/8	-	13-1/8
	5	5	6	4	9-1/2	-	6-3/4	2-1/4	3-5/8	-	13-1/8
	5-1/2	5-1/2	6	4	9-1/2	-	6-3/4	2-1/4	3-5/8	-	13-1/8
10	4-1/2	4-1/2	8	5	12-1/8	-	8-7/8	2-15/16	4-9/16	-	16-3/16
	5	5	8	5-1/4	12-1/8	-	8-7/8	3-3/16	4-13/16	-	16-7/16
	5-1/2	5-1/2	8	5-1/4	12-1/8	-	8-7/8	3-3/16	4-13/16	-	16-7/16
	7	7	8	5-1/4	12-1/8	-	8-7/8	3-3/16	4-13/16	-	16-7/16
12	5-1/2	5-1/2	9-5/8	5-5/8	14-1/2	-	10-1/2	3-3/16	5-3/16	-	18-13/16
	7	7	9-5/8	5-7/8	14-1/2	-	10-1/2	3-7/16	5-7/16	-	19-1/16
	8	8	9-5/8	5-7/8	14-1/2	-	10-1/2	3-7/16	5-7/16	-	19-1/16
14	7	7	9-7/8	6-3/8	15-5/8	-	11-1/8	3-1/2	5-3/4	-	20-1/4
	8	8	9-7/8	6-3/8	15-5/8	-	11-1/8	3-1/2	5-3/4	-	20-1/4
	10	10	9-7/8	6-3/8	15-5/8	-	11-1/8	3-1/2	5-3/4	-	20-1/4
16	8	8	11-3/8	7-3/8	18-1/8	-	12-5/8	4	6-3/4	-	23-9/16
	9	9	11-3/8	7-3/8	18-1/8	-	12-5/8	4	6-3/4	-	23-9/16
	10	10	11-3/8	7-3/8	18-1/8	-	12-5/8	4	6-3/4	-	23-9/16
18	9	9	12-3/8	8-5/8	21-1/8	-	14-5/8	4-1/4	7-1/2	-	26-13/16
	10	10	12-3/8	8-5/8	21-1/8	-	14-5/8	4-1/4	7-1/2	-	26-13/16
20	10	10	13-3/8	9-5/8	23-5/8	-	15-7/8	4-1/2	8-3/8	-	29-9/16