

Class 5A

Low Pressure NFPA Aluminum Cylinders

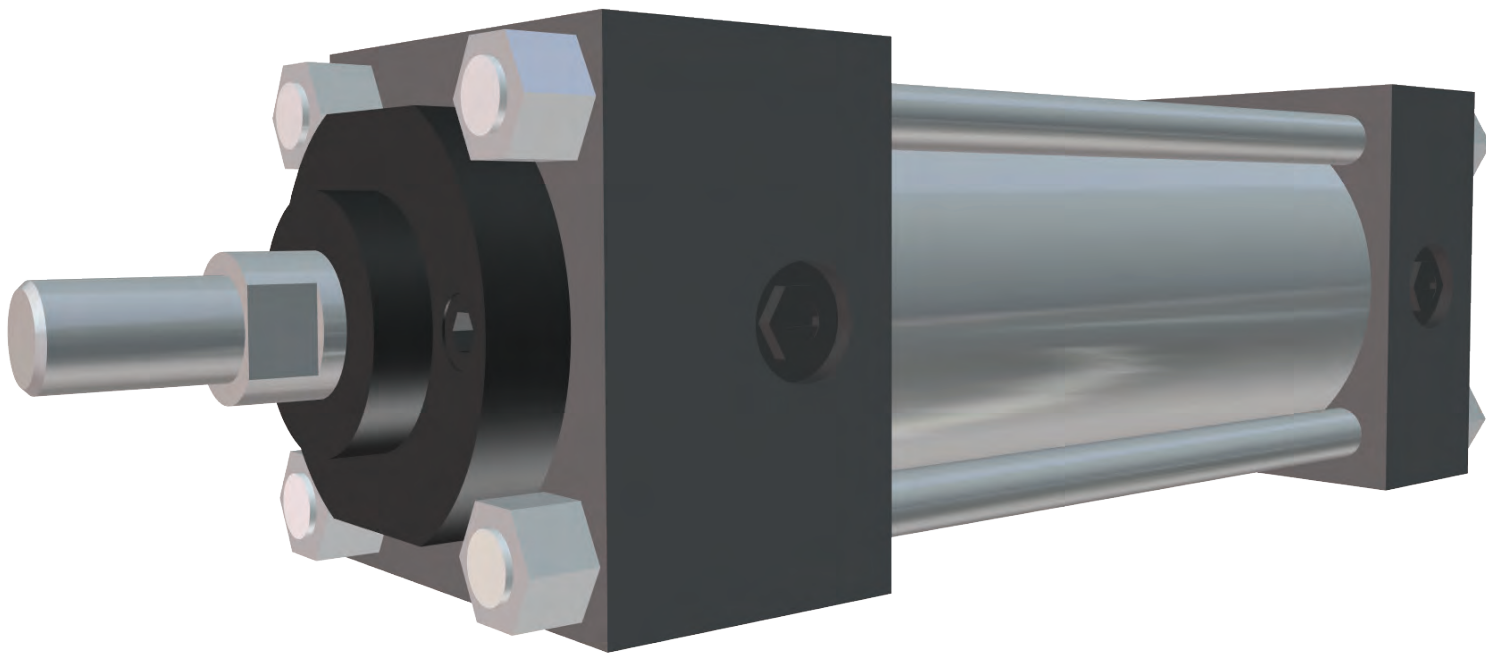

ORDERING CODE EXAMPLE

CL5A - 4.00 x 12.00 - E* - AA - 1.00 - 4 - OPT

CLASS		STROKE		ROD DIAMETER		ROD END THREAD		CUSHIONS		OPTIONS	
5A	250 PSI AIR ALUMINUM	UP TO 120"		SEE CHART AT RESPECTIVE BORE SIZE FOR ROD SIZES AVAILABLE		SEE CHART PAGE 75)				(CALL OUT BELOW CYLINDER DESCRIPTION)	
Bore		MODEL		ROD END THREAD		CUSHIONS				TYPE B SEALS - FLUOROCARBON	
1.50		D	MF1 - FRONT FLANGE	1 FULL MALE THREAD		NN NO CUSHIONS				DIM. WF - ROD EXTENSION	
2.00		C	MF2 - REAR FLANGE	3 INTERMEDIATE MALE		AA CUSHIONED BOTH ENDS				DIM. A - EXTENDED ROD THREAD	
2.50		DG	ME3 - FRONT MOUNTING HOLES	4 SMALL MALE (STANDARD)		NA NO CUSHION ROD END CUSHIONED BLIND END				EMS-201: ELECTROLESS NICKEL PLATING (SEE PAGE 92)	
3.25		CJ	ME4 - REAR MOUNTING HOLES	5 FEMALE THREAD		AN CUSHIONED ROD END NO CUSHION BLIND END				MAGNETIC PISTON	
4.00		E	MP1 - FIXED REAR CLEVIS	6 PLAIN END (NO THREADS)						METALLIC ROD SCRAPER	
5.00		HE	MP2 - DETACHABLE REAR CLEVIS	7 ROD COUPLER END						OPTIONAL PORT LOCATIONS	
6.00		E4	MP4 - DETACHABLE REAR EYE	9 STUDDED						STAINLESS STEEL PISTON ROD	
8.00		AP	MS1 - ANGLE PLATE							STAINLESS STEEL TIE RODS	
10.00		A	MS2 - FOOT MOUNT							STAINLESS STEEL TIE ROD NUTS	
12.00		S	MS4 - SIDE TAPPED HOLES							STAINLESS STEEL FASTENERS	
		FR	MT1 - FRONT TRUNNION							STAINLESS STEEL ALL: INCLUDES PISTON ROD, TIE RODS, TIE ROD NUTS AND FASTENERS	
		FB	MT2 - REAR TRUNNION							STAINLESS STEEL CUSHION NEEDLES	
		F	MT4 - INTERMEDIATE TRUNNION							STOP TUBE - SPECIFY STOP TUBE LENGTH, EFFECTIVE STROKE AND TOTAL STROKE	
		H	MX0 - NO MOUNT								
		T	MX1 - EXTENDED TIE RODS (BOTH ENDS)								
		TB	MX2 - EXTENDED TIE RODS (CAP END)								
		TR	MX3 - EXTENDED TIE RODS (ROD END)								

* FOR DOUBLE ROD END CYLINDERS, ADD AN "X" BEFORE THE MODEL IDENTIFICATION (EXAMPLE: XA, XD, XFR).

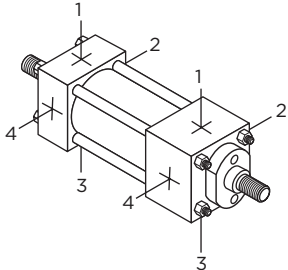
STANDARD PORT AND CUSHION ADJUSTMENT POSITIONS	
• PORTS - POSITION 1	
• CUSHION ADJUSTMENT - POSITION 2	
<p>NOTE: When optional port locations are ordered, specify both port locations, even if one port is in the standard location.</p>	

COMBINATION MOUNTS

Cylinders can be ordered with a combination of mounts for added design flexibility.

HOW TO ORDER:

Combination mount part numbers can be constructed by adding a dash (-) in between the desired mounts in the part number. Consult factory for more information.

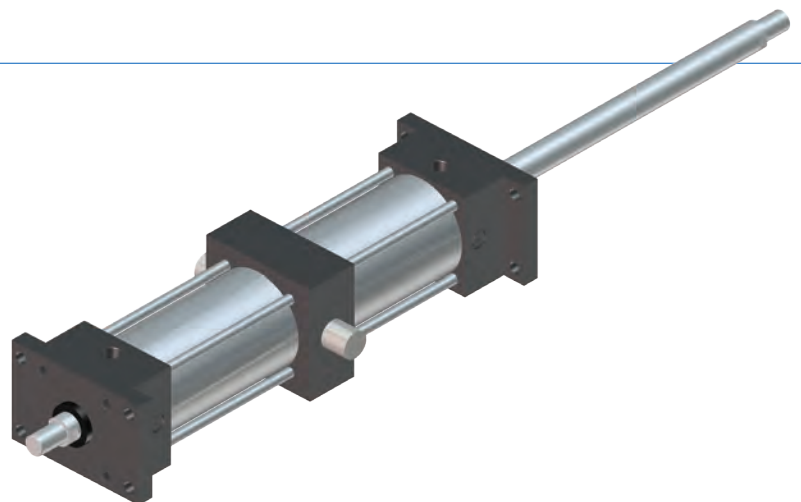

MODEL AP (NFPA MS1) 1.50" - 8.00" BORES

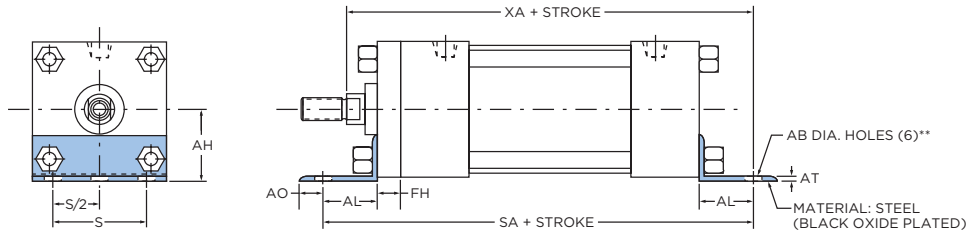

MODEL A (NFPA MS2) 1.50" - 8.00" BORES

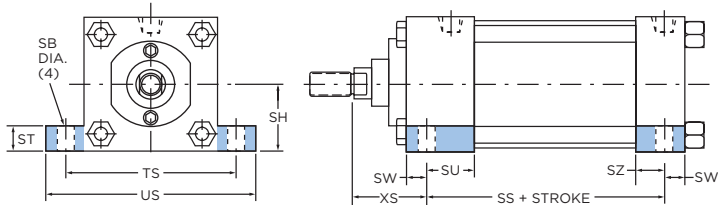

MODEL S (NFPA MS4)

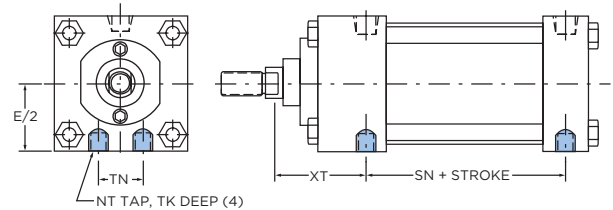

MODEL H (NO MOUNT)

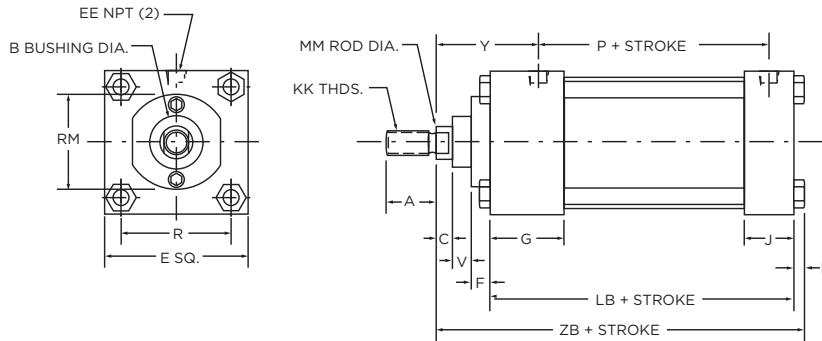

Table 1 BASIC DIMENSIONS STANDARD & OVERSIZE RODS

BORE	ROD DIAMETER	A	B	C	E	EE	F	G	J	K	KK	LB	MM	P	R	RM	V	Y	ZB
1.50	0.63	0.750	1.125	0.375	2.000	0.375	0.375	1.500	1.000	0.250	7/16-20	3.625	0.625	2.375	1.438	2.00	0.250	1.875	4.875
	1.00	1.125	1.500	0.500	2.000	0.375	0.375	1.500	1.000	0.250	3/4-16	3.625	1.000	2.375	1.438	2.00	0.500	2.250	5.250
2.00	0.63	0.750	1.125	0.375	2.500	0.375	0.375	1.500	1.000	0.313	7/16-20	3.625	0.625	2.375	1.844	2.00	0.250	1.875	4.938
	1.00	1.125	1.500	0.500	2.500	0.375	0.375	1.500	1.000	0.313	3/4-16	3.625	1.000	2.375	1.844	2.50	0.500	2.250	5.313
2.50	0.63	0.750	1.125	0.375	3.000	0.375	0.375	1.500	1.000	0.313	7/16-20	3.750	0.625	2.500	2.188	2.00	0.250	1.875	5.063
	1.00	1.125	1.500	0.500	3.000	0.375	0.375	1.500	1.000	0.313	3/4-16	3.750	1.000	2.500	2.188	3.00	0.500	2.250	5.438
3.25	1.00	1.125	1.500	0.500	3.750	0.500	0.625	1.750	1.250	0.375	3/4-16	4.250	1.000	2.750	2.766	2.75	0.250	2.375	6.000
	1.38	1.625	2.000	0.625	3.750	0.500	0.625	1.750	1.250	0.375	1-14	4.250	1.000	1.375	2.766	3.75	0.375	2.625	6.250
4.00	1.00	1.125	1.500	0.500	4.500	0.500	0.625	1.750	1.250	0.375	3/4-16	4.250	1.000	2.750	3.320	2.75	0.250	2.375	6.000
	1.38	1.625	2.000	0.625	4.500	0.500	0.625	1.750	1.250	0.375	1-14	4.250	1.000	1.375	3.320	3.50	0.375	2.625	6.250
5.00	1.00	1.125	1.500	0.500	5.500	0.500	0.625	1.750	1.250	0.438	3/4-16	4.500	1.000	3.000	4.100	2.75	0.250	2.375	6.313
	1.38	1.625	2.000	0.625	5.500	0.500	0.625	1.750	1.250	0.438	1-14	4.500	1.000	1.375	4.100	3.50	0.375	2.625	6.563
6.00	1.38	1.625	2.000	0.625	6.500	0.750	0.625	2.000	1.500	0.438	1-14	5.000	1.375	3.250	4.875	3.50	0.375	2.750	7.063
	1.75	2.000	2.375	0.750	6.500	0.750	0.625	2.000	1.500	0.438	1-1/4-12	5.000	1.750	3.250	4.875	3.50	0.500	3.000	7.313
8.00	1.38	1.625	2.000	0.625	8.500	0.750	0.625	2.000	1.500	0.563	1-14	5.125	1.375	3.375	6.438	3.50	0.375	2.750	7.313
	1.75	2.000	2.375	0.750	8.500	0.750	0.625	2.000	1.500	0.563	1-1/4-12	5.125	1.750	3.375	6.438	3.50	0.500	3.000	7.563
10.00	1.75	2.000	2.375	0.750	10.625	1.000	0.625	2.250	2.000	0.688	1-1/4-12	6.375	1.750	4.313	7.922	3.50	0.500	3.063	8.938
	2.00	2.250	2.625	0.875	10.625	1.000	0.750	2.250	2.000	0.688	1-1/2-12	6.375	2.000	4.313	7.922	5.00	0.375	3.188	9.063
12.00	2.00	2.250	2.625	0.875	12.750	1.000	0.750	2.250	2.000	0.688	1-1/2-12	6.875	2.000	4.813	9.400	5.00	0.375	3.188	9.563
	2.50	3.000	3.125	1.000	12.750	1.000	0.750	2.250	2.000	0.688	1-7/8-12	6.875	2.500	4.813	9.400	5.00	0.500	3.438	9.813

ANGLE AND SIDE LUG MOUNT CYLINDERS

1.50" THROUGH 12.00" BORE

Table 2 MODEL AP ANGLE BASE MOUNT DIMENSIONS

BORE	ROD DIAMETER	AB	AH	AL	AO	AT	FH	S	SA ADD STROKE	XA ADD STROKE
1.50	0.63	0.438	1.188	1.000	0.375	0.188	0.375	1.250	6.000	5.625
	1.00	0.438	1.188	1.000	0.375	0.188	0.375	1.250	6.000	6.000
2.00	0.63	0.438	1.438	1.000	0.375	0.188	0.375	1.750	6.000	5.625
	1.00	0.438	1.438	1.000	0.375	0.188	0.375	1.750	6.000	6.000
2.50	0.63	0.438	1.625	1.000	0.375	0.188	0.375	2.250	6.125	5.750
	1.00	0.438	1.625	1.000	0.375	0.188	0.375	2.250	6.125	6.125
3.25	1.00	0.563	1.938	1.250	0.500	0.125	0.625	2.750	7.375	6.875
	1.38	0.563	1.938	1.250	0.500	0.125	0.625	2.750	7.375	7.125
4.00	1.00	0.563	2.250	1.250	0.500	0.125	0.625	3.500	7.375	6.875
	1.38	0.563	2.250	1.250	0.500	0.125	0.625	3.500	7.375	7.125
5.00	1.00	0.688	2.750	1.375	0.625	0.188	0.625	4.250	7.875	7.250
	1.38	0.688	2.750	1.375	0.625	0.188	0.625	4.250	7.875	7.500
6.00	1.38	0.813	3.250	1.375	0.625	0.188	0.750	5.250	8.500	8.000
	1.75	0.813	3.250	1.375	0.625	0.188	0.750	5.250	8.500	8.250
8.00	1.38	0.813	4.250	1.813	0.688	0.250	0.625*	7.125	8.750	8.563
	1.75	0.813	4.250	1.813	0.688	0.250	0.625*	7.125	8.750	8.813

* 3.50" diameter round retainer on 8.00" bore (AP BRACKET BOLTED DIRECTLY TO HEAD). ** 1.50" bore has four (4) AB diameter holes.

Table 3 MODEL A SIDE LUG BASE MOUNT DIMENSIONS

BORE	ROD DIAMETER	SB	SH	ST	SU	SW	SZ	TS	US	XS	SS ADD STROKE
1.50	0.63	0.438	1.000	0.500	1.125	0.375	0.625	2.750	3.500	1.375	2.875
	1.00	0.438	1.000	0.500	1.125	0.375	0.625	2.750	3.500	1.750	2.875
2.00	0.63	0.438	1.250	0.500	1.125	0.375	0.625	3.250	4.000	1.375	2.875
	1.00	0.438	1.250	0.500	1.125	0.375	0.625	3.250	4.000	1.750	2.875
2.50	0.63	0.438	1.500	0.500	1.125	0.375	0.625	3.750	4.500	1.375	3.000
	1.00	0.438	1.500	0.500	1.125	0.375	0.625	3.750	4.500	1.750	3.000
3.25	1.00	0.563	1.875	0.750	1.250	0.500	0.750	4.750	5.750	1.875	3.250
	1.38	0.563	1.875	0.750	1.250	0.500	0.750	4.750	5.750	2.125	3.250
4.00	1.00	0.563	2.250	0.750	1.250	0.500	0.750	5.500	6.500	1.875	3.250
	1.38	0.563	2.250	0.750	1.250	0.500	0.750	5.500	6.500	2.125	3.250
5.00	1.00	0.813	2.750	1.000	1.063	0.688	0.563	6.875	8.250	2.063	3.125
	1.38	0.813	2.750	1.000	1.063	0.688	0.563	6.875	8.250	2.313	3.125
6.00	1.38	0.813	3.250	1.000	1.313	0.688	0.813	7.875	9.250	2.313	3.625
	1.75	0.813	3.250	1.000	1.313	0.688	0.813	7.875	9.250	2.563	3.625
8.00	1.38	0.813	4.250	1.000	1.313	0.688	0.813	9.875	11.250	2.313	3.750
	1.75	0.813	4.250	1.000	1.313	0.688	0.813	9.875	11.250	2.563	3.750

Table 4 MODEL S BOTTOM TAPPED BASE MOUNT DIMENSIONS

BORE	ROD DIAMETER	E/2	NT	TK	TN	XT	SN ADD STROKE
1.50	0.63	1.000	1/4-20	0.375	0.625	1.938	2.250
	1.00	1.000	1/4-20	0.375	0.625	2.313	2.250
2.00	0.63	1.250	5/16-18	0.500	0.875	1.938	2.250
	1.00	1.250	5/16-18	0.500	0.875	2.313	2.250
2.50	0.63	1.500	3/8-16	0.625	1.250	1.938	2.3875
	1.00	1.500	3/8-16	0.625	1.250	2.313	2.3875
3.25	1.00	1.875	1/2-13	0.750	1.500	2.438	2.625
	1.38	1.875	1/2-13	0.750	1.500	2.688	2.625
4.00	1.00	2.250	1/2-13	0.750	2.063	2.438	2.625
	1.38	2.250	1/2-13	0.750	2.063	2.688	2.625
5.00	1.00	2.750	5/8-11	1.000	2.688	2.438	2.875
	1.38	2.750	5/8-11	1.000	2.688	2.688	2.875
6.00	1.38	3.250	3/4-10	1.125	3.250	2.813	3.125
	1.75	3.250	3/4-10	1.125	3.250	3.063	3.125
8.00	1.38	4.250	3/4-10	1.125	4.500	2.813	3.250
	1.75	4.250	3/4-10	1.125	4.500	3.063	3.250
10.00	1.75	5.313	1-8	1.500	5.500	3.125	4.125
	2.00	5.313	1-8	1.500	5.500	3.250	4.125
12.00	2.00	6.375	1-8	1.500	7.250	3.250	4.625
	2.50	6.375	1-8	1.500	7.250	3.500	4.625