

Class 5A

Low Pressure NFPA Aluminum Cylinders

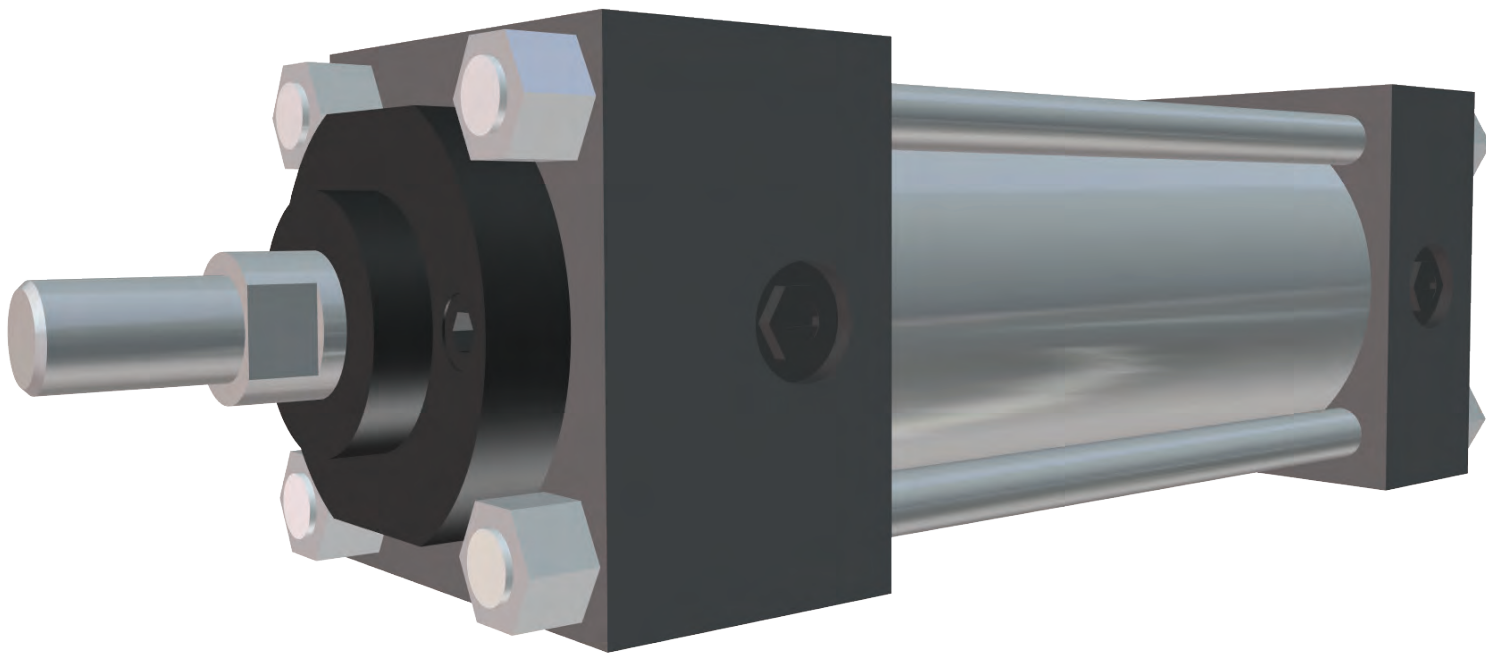

TABLE OF CONTENTS

Mounting Styles Index 72

How To Order 73
 Ordering Code Example 73
 Combination Mounts 73

Class 5A Features 74

Piston Rod Dimension Data 75

Flange Mount Cylinders
 1.50" Through 12.00" Bore 76

Clevis and Eye Mount Cylinders
 1.50" Through 12.00" Bore 78

Angle and Side Lug Mount Cylinders
 1.50" Through 12.00" Bore 80

Trunnion Mount Cylinders
 1.50" Through 8.00" Bore 82

Tie Rod Mount Cylinders
 1.50" Through 12.00" Bore 84

Double Rod End Cylinders
 1.50" Through 12.00" Bore 86

Technical Data 87

Accessories 89

Options and Modifications 90

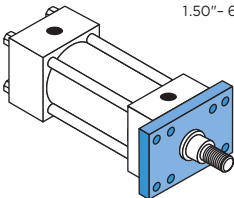
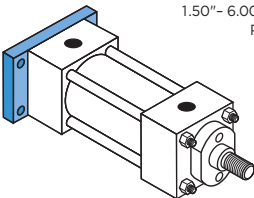
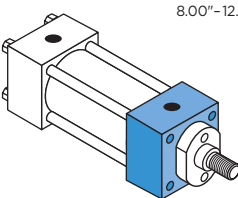
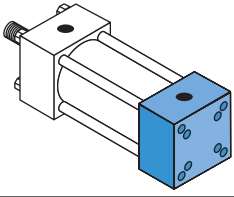
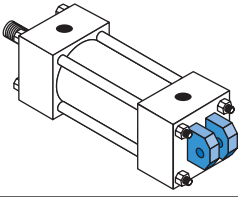
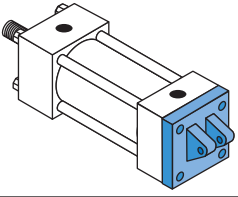
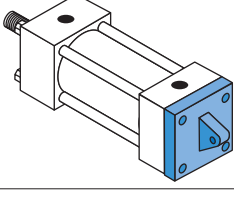
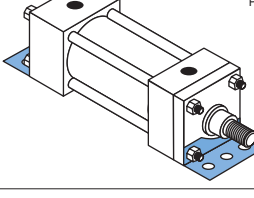
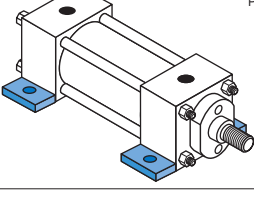
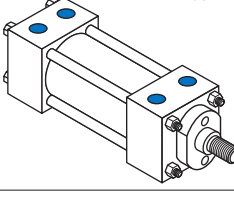
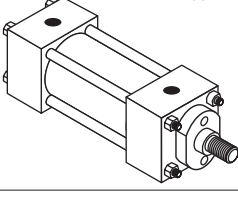
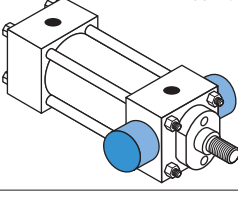
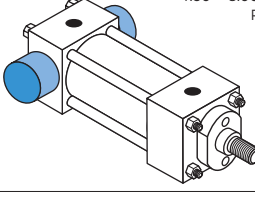
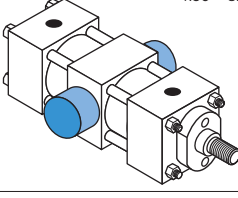
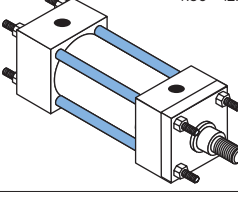
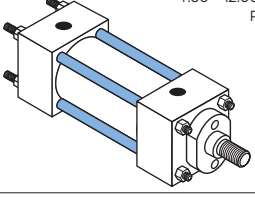
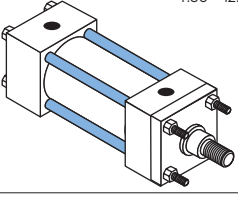
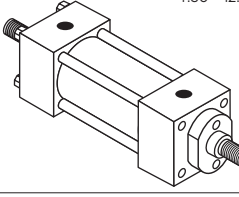
<p>MODEL D (NFPA MF1) 1.50"- 6.00" BORE PAGE 76</p> 	<p>MODEL C (NFPA MF2) 1.50"- 6.00" BORE PAGE 76</p> 	<p>MODEL DG (NFPA ME3) 8.00"-12.00" BORE PAGE 76</p> 
<p>MODEL CJ (NFPA ME4) 8.00"-12.00" BORE PAGE 76</p> 	<p>MODEL E (NFPA MP1) 1.50"-12.00" BORE PAGE 78</p> 	<p>MODEL HE (NFPA MP2) 1.50"- 6.00" BORE PAGE 78</p> 
<p>MODEL E4 (NFPA MP4) 1.50"- 6.00" BORE PAGE 78</p> 	<p>MODEL AP (NFPA MS1) 1.50"- 8.00" BORE PAGE 80</p> 	<p>MODEL A (NFPA MS2) 1.50"- 8.00" BORE PAGE 80</p> 
<p>MODEL S (NFPA MS4) 1.50"-12.00" BORE PAGE 80</p> 	<p>MODEL H (NO MOUNT) 1.50"-12.00" BORE PAGE 80</p> 	<p>MODEL FR (NFPA MT1) 1.50"- 8.00" BORE PAGE 82</p> 
<p>MODEL FB (NFPA MT2) 1.50"- 8.00" BORE PAGE 82</p> 	<p>MODEL F (NFPA MT4) 1.50"- 8.00" BORE PAGE 82</p> 	<p>MODEL T (NFPA MX1) 1.50"-12.00" BORE PAGE 84</p> 
<p>MODEL TB (NFPA MX2) 1.50"-12.00" BORE PAGE 84</p> 	<p>MODEL TR (NFPA MX3) 1.50"-12.00" BORE PAGE 84</p> 	<p>MODEL XH (NO MOUNT) 1.50"-12.00" BORE PAGE 86</p> 

ORDERING CODE EXAMPLE

CL5A - 4.00 x 12.00 - E* - AA - 1.00 - 4 - OPT

CLASS		STROKE		ROD DIAMETER		ROD END THREAD		CUSHIONS		OPTIONS	
5A	250 PSI AIR ALUMINUM	UP TO 120"		SEE CHART AT RESPECTIVE BORE SIZE FOR ROD SIZES AVAILABLE		SEE CHART PAGE 75)				(CALL OUT BELOW CYLINDER DESCRIPTION)	
Bore		MODEL		ROD END THREAD		CUSHIONS				TYPE B SEALS - FLUOROCARBON	
1.50		D	MF1 - FRONT FLANGE	1 FULL MALE THREAD		NN NO CUSHIONS				DIM. WF - ROD EXTENSION	
2.00		C	MF2 - REAR FLANGE	3 INTERMEDIATE MALE		AA CUSHIONED BOTH ENDS				DIM. A - EXTENDED ROD THREAD	
2.50		DG	ME3 - FRONT MOUNTING HOLES	4 SMALL MALE (STANDARD)		NA NO CUSHION ROD END CUSHIONED BLIND END				EMS-201: ELECTROLESS NICKEL PLATING (SEE PAGE 92)	
3.25		CJ	ME4 - REAR MOUNTING HOLES	5 FEMALE THREAD		AN CUSHIONED ROD END NO CUSHION BLIND END				MAGNETIC PISTON	
4.00		E	MP1 - FIXED REAR CLEVIS	6 PLAIN END (NO THREADS)						METALLIC ROD SCRAPER	
5.00		HE	MP2 - DETACHABLE REAR CLEVIS	7 ROD COUPLER END						OPTIONAL PORT LOCATIONS	
6.00		E4	MP4 - DETACHABLE REAR EYE	9 STUDDED						STAINLESS STEEL PISTON ROD	
8.00		AP	MS1 - ANGLE PLATE							STAINLESS STEEL TIE RODS	
10.00		A	MS2 - FOOT MOUNT							STAINLESS STEEL TIE ROD NUTS	
12.00		S	MS4 - SIDE TAPPED HOLES							STAINLESS STEEL FASTENERS	
		FR	MT1 - FRONT TRUNNION							STAINLESS STEEL ALL: INCLUDES PISTON ROD, TIE RODS, TIE ROD NUTS AND FASTENERS	
		FB	MT2 - REAR TRUNNION							STAINLESS STEEL CUSHION NEEDLES	
		F	MT4 - INTERMEDIATE TRUNNION							STOP TUBE - SPECIFY STOP TUBE LENGTH, EFFECTIVE STROKE AND TOTAL STROKE	
		H	MX0 - NO MOUNT								
		T	MX1 - EXTENDED TIE RODS (BOTH ENDS)								
		TB	MX2 - EXTENDED TIE RODS (CAP END)								
		TR	MX3 - EXTENDED TIE RODS (ROD END)								

* FOR DOUBLE ROD END CYLINDERS, ADD AN "X" BEFORE THE MODEL IDENTIFICATION (EXAMPLE: XA, XD, XFR).

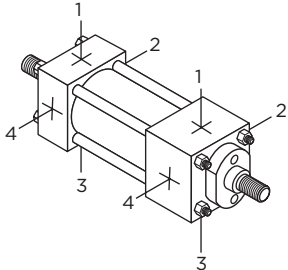
STANDARD PORT AND CUSHION ADJUSTMENT POSITIONS	
• PORTS - POSITION 1	
• CUSHION ADJUSTMENT - POSITION 2	
<p>NOTE: When optional port locations are ordered, specify both port locations, even if one port is in the standard location.</p>	

COMBINATION MOUNTS

Cylinders can be ordered with a combination of mounts for added design flexibility.

HOW TO ORDER:

Combination mount part numbers can be constructed by adding a dash (-) in between the desired mounts in the part number. Consult factory for more information.

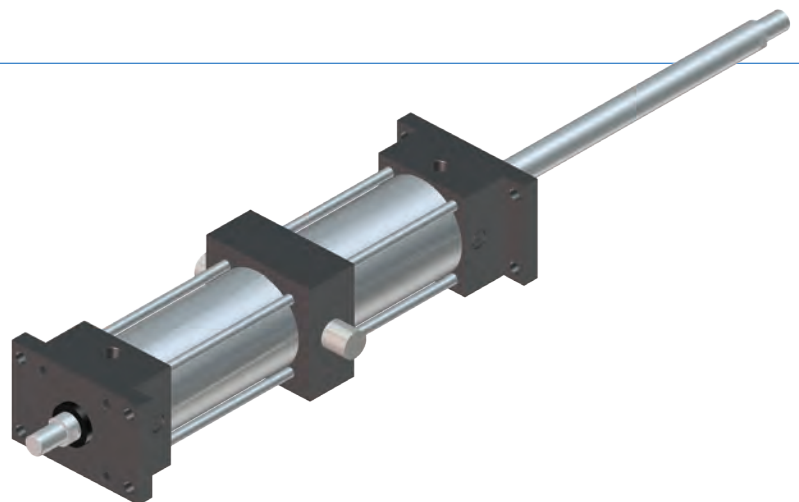

CLASS 5A ALUMINUM NFPA CYLINDERS

HEAVY-DUTY DESIGN FOR RELIABLE, CONSISTENT OPERATION

OPERATING PRESSURE	250 PSI Air	
OPERATING TEMPERATURE	Type A (Nitrile):	20°F to 200°F (-25°C to 90°C)
	Type B (Fluorocarbon):	0°F to 400°F (-20°C to 200°C)

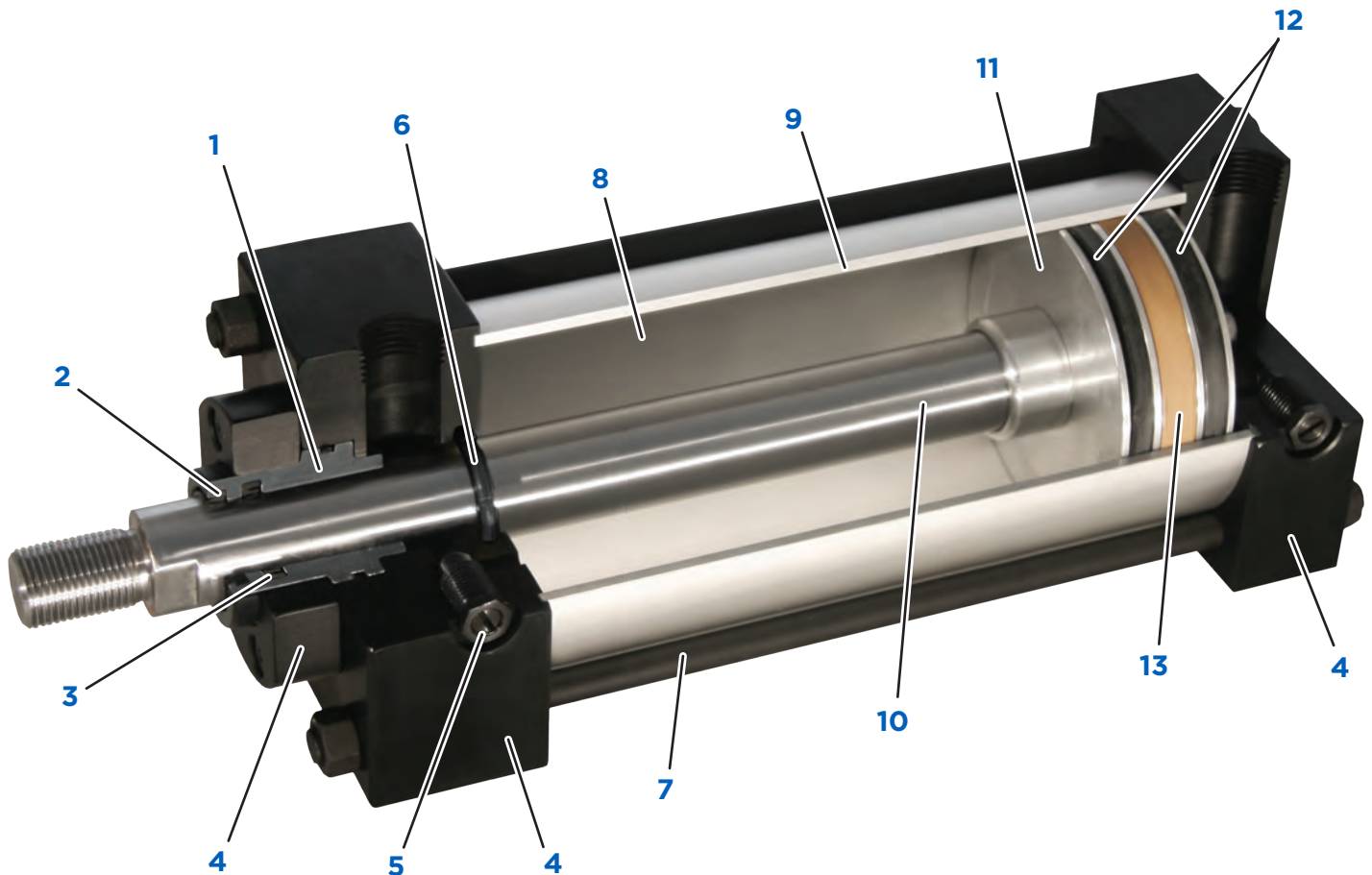

1. ROD BUSHING -

Precision machined from 150,000 PSI rated graphite-filled cast iron and PTFE coated to reduce friction and extend cycle life. Bushing design traps lubrication in effective bearing area.

2. ROD WIPER -

Abrasion resistant urethane provides aggressive wiping action in all environments. External lip design prevents debris from entering cylinder.

3. ROD SEALS -

Heavy lip design Carboxylated Nitrile construction. Seals are pressure activated and wear-compensating for long life (self-lubricating material).

4. HEAD, CAP & RETAINER -

Precision machined from high strength 6061-T6 aluminum alloy. Black anodized for corrosion resistance.

5. CUSHION ADJUSTMENT NEEDLE -

Adjustable steel needle design has fine thread metering and is positively captured to prevent needle ejection during adjustment.

6. CUSHIONS -

Floating cushion seal designed for maximum cushion performance, quick return stroke break-away and extended life.

7. TIE RODS -

Pre-stressed high carbon steel tie rod construction eliminates axial loading of cylinder tube and maintains compression on tube and end seals.

8. PERMANENT LUBRICATION -

Permanently lubricated with Magnalube-G PTFE based grease on all internal components. This is a non-migratory type high performance grease providing outstanding service life. No additional lubrication is required.

9. CYLINDER TUBE -

Precision machined from 6063-T6832 high tensile aluminum alloy and hard coat to 60 Rc for wear resistance and extended cycle life.

10. PISTON ROD -

Precision machined from high yield, polished and hard chrome plated steel.

11. PISTON -

Precision machined from 6061-T651 aluminum alloy, provides an excellent bearing surface for extended cylinder life.

12. PISTON SEALS -

Heavy lip design Carboxylated Nitrile construction. Seals are pressure activated and wear-compensating for long life (self-lubricating material).

13. PISTON WEAR BAND -

90% Virgin PTFE and 10% Polyphenylene Sulfide-filled wear band; extremely low wear rate.

PISTON ROD DIMENSION DATA

ABOUT ROD END TYPES

Type 4* Male Rod End is STANDARD.

Other NFPA Styles are available (see chart).

Special rod ends are available, including metric threads, coarse (UNC) threads, etc. Consult factory for more information. For custom thread lengths, specify Dim. A = (length).

PISTON ROD END TYPES

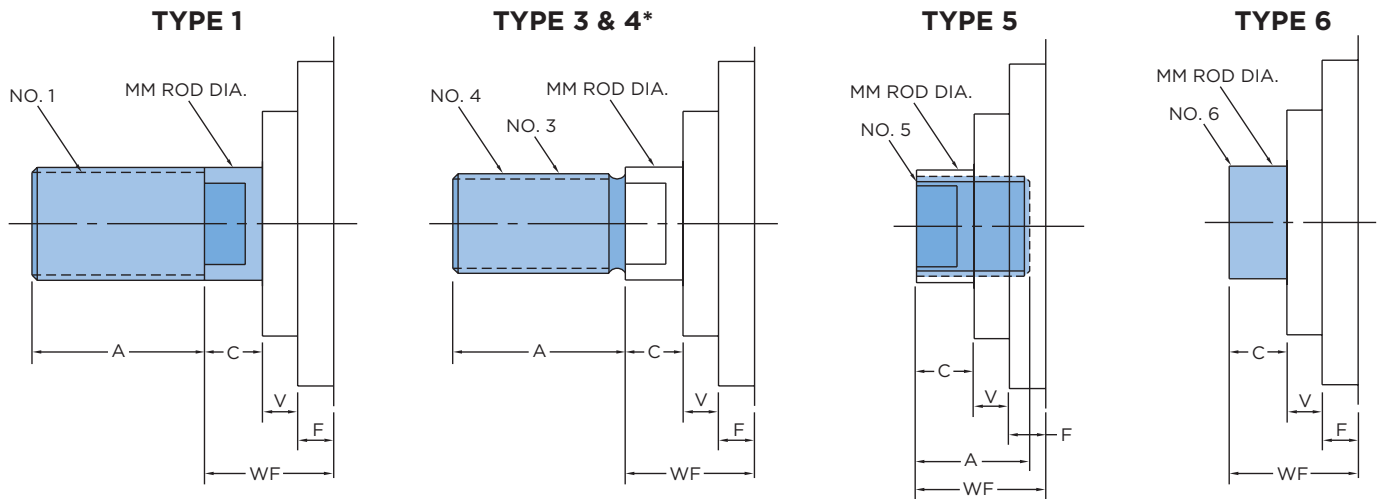

BORE	ROD MM	ROD END TYPE					A	C	F	V	WF
		NO. 1	NO. 3	NO. 4*	NO. 5	NO. 6					
1.50	0.63	0.63-18	0.50-20	0.44-20	0.44-20	No Threads	0.75	0.38	0.38	0.25	1.00
	1.00	1.00-14	0.88-14	0.75-16	0.75-16	No Threads	1.13	0.50	0.38	0.50	1.38
2.00	0.63	0.63-18	0.50-20	0.44-20	0.44-20	No Threads	0.75	0.38	0.38	0.25	1.00
	1.00	1.00-14	0.88-14	0.75-16	0.75-16	No Threads	1.13	0.50	0.38	0.50	1.38
2.50	0.63	0.63-18	0.50-20	0.44-20	0.44-20	No Threads	0.75	0.38	0.38	0.25	1.00
	1.00	1.00-14	0.88-14	0.75-16	0.75-16	No Threads	1.13	0.50	0.38	0.50	1.38
3.25	1.00	1.00-14	0.88-14	0.75-16	0.75-16	No Threads	1.13	0.50	0.63	0.25	1.38
	1.38	1.38-12	1.25-12	1.00-14	1.00-14	No Threads	1.63	0.63	0.63	0.38	1.63
4.00	1.00	1.00-14	0.88-14	0.75-16	0.75-16	No Threads	1.13	0.50	0.63	0.25	1.38
	1.38	1.38-12	1.25-12	1.00-14	1.00-14	No Threads	1.63	0.63	0.63	0.38	1.63
5.00	1.00	1.00-14	0.88-14	0.75-16	0.75-16	No Threads	1.13	0.50	0.63	0.25	1.38
	1.38	1.38-12	1.25-12	1.00-14	1.00-14	No Threads	1.63	0.63	0.63	0.38	1.63
6.00	1.38	1.38-12	1.25-12	1.00-14	1.00-14	No Threads	1.63	0.63	0.63	0.38	1.63
	1.75	1.75-12	1.50-12	1.25-12	1.25-12	No Threads	2.00	0.75	0.63	0.50	1.88
8.00	1.38	1.38-12	1.25-12	1.00-14	1.00-14	No Threads	1.63	0.63	0.63	0.38	1.63
	1.75	1.75-12	1.50-12	1.25-12	1.25-12	No Threads	2.00	0.75	0.63	0.50	1.88
10.00	1.75	1.75-12	1.50-12	1.25-12	1.25-12	No Threads	2.00	0.75	0.63	0.50	1.88
	2.00	2.00-12	1.75-12	1.50-12	1.50-12	No Threads	2.25	0.88	0.75	0.38	2.00
12.00	2.00	2.00-12	1.75-12	1.50-12	1.50-12	No Threads	2.25	0.88	0.75	0.38	2.00
	2.50	2.50-12	2.25-12	1.88-12	1.88-12	No Threads	3.00	1.00	0.75	0.50	2.25

MODEL D (NFPA MF1) 1.50" - 6.00" BORES

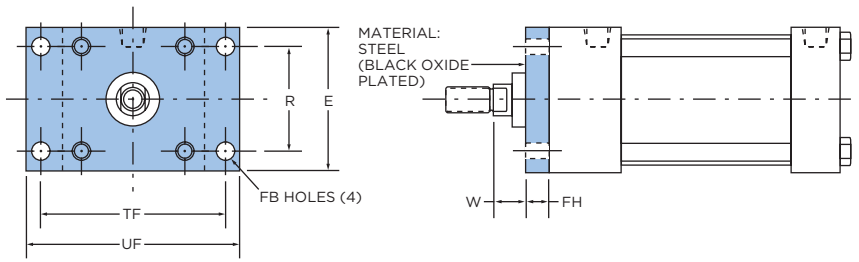

MODEL C (NFPA MF2) 1.50" - 6.00" BORES

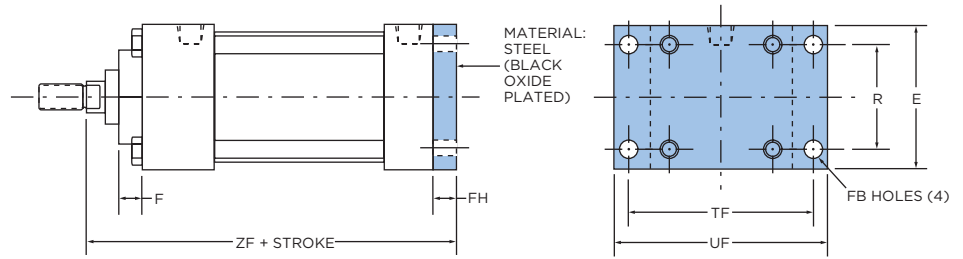

MODEL DG (NFPA ME3) 8.00" - 12.00" BORES

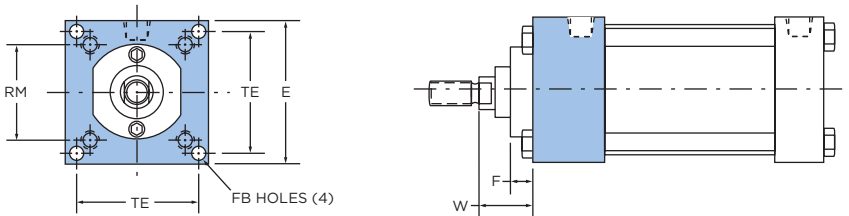

MODEL CJ (NFPA ME4) 8.00" - 12.00" BORES

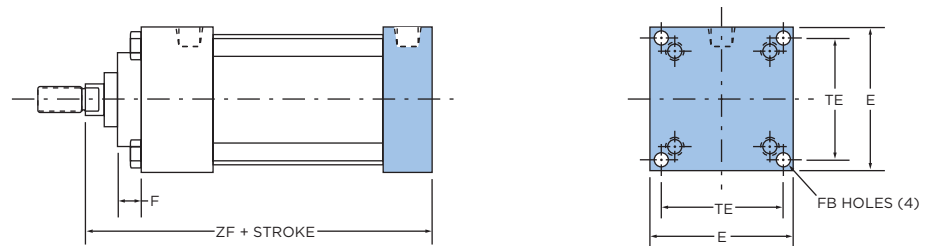

BASIC DIMENSIONS

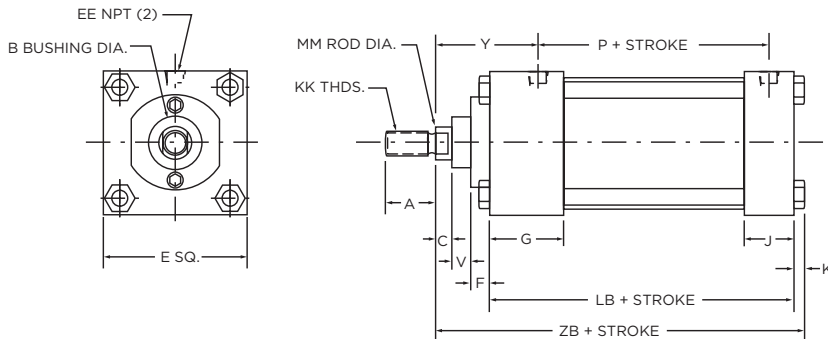

FLANGE MOUNT CYLINDERS

1.50" THROUGH 12.00" BORE

Table 1 BASIC DIMENSIONS STANDARD & OVERSIZE RODS

BORE	ROD DIAMETER	A	B	C	EE	G	J	K	KK	LB	MM	P	V	Y	ZB
1.50	0.63	0.750	1.125	0.375	0.375	1.500	1.000	0.250	7/16-20	3.625	0.625	2.375	0.250	1.875	4.875
	1.00	1.125	1.500	0.500	0.375	1.500	1.000	0.250	3/4-16	3.625	1.000	2.375	0.500	2.250	5.250
2.00	0.63	0.750	1.125	0.375	0.375	1.500	1.000	0.313	7/16-20	3.625	0.625	2.375	0.250	1.875	4.938
	1.00	1.125	1.500	0.500	0.375	1.500	1.000	0.313	3/4-16	3.625	1.000	2.375	0.500	2.250	5.313
2.50	0.63	0.750	1.125	0.375	0.375	1.500	1.000	0.313	7/16-20	3.750	0.625	2.500	0.250	1.875	5.063
	1.00	1.125	1.500	0.500	0.375	1.500	1.000	0.313	3/4-16	3.750	1.000	2.500	0.500	2.250	5.438
3.25	1.00	1.125	1.500	0.500	0.500	1.750	1.250	0.375	3/4-16	4.250	1.000	2.750	0.250	2.375	6.000
	1.38	1.625	2.000	0.625	0.500	1.750	1.250	0.375	1-14	4.250	1.000	1.375	0.375	2.625	6.250
4.00	1.00	1.125	1.500	0.500	0.500	1.750	1.250	0.375	3/4-16	4.250	1.000	2.750	0.250	2.375	6.000
	1.38	1.625	2.000	0.625	0.500	1.750	1.250	0.375	1-14	4.250	1.000	1.375	0.375	2.625	6.250
5.00	1.00	1.125	1.500	0.500	0.500	1.750	1.250	0.438	3/4-16	4.500	1.000	3.000	0.250	2.375	6.313
	1.38	1.625	2.000	0.625	0.500	1.750	1.250	0.438	1-14	4.500	1.000	1.375	0.375	2.625	6.563
6.00	1.38	1.625	2.000	0.625	0.750	2.000	1.500	0.438	1-14	5.000	1.375	3.250	0.375	2.750	7.063
	1.75	2.000	2.375	0.750	0.750	2.000	1.500	0.438	1-1/4-12	5.000	1.750	3.250	0.500	3.000	7.313
8.00	1.38	1.625	2.000	0.625	0.750	2.000	1.500	0.563	1-14	5.125	1.375	3.375	0.375	2.750	7.313
	1.75	2.000	2.375	0.750	0.750	2.000	1.500	0.563	1-1/4-12	5.125	1.750	3.375	0.500	3.000	7.563
10.00	1.75	2.000	2.375	0.750	1.000	2.250	2.000	0.688	1-1/4-12	6.375	1.750	4.313	0.500	3.063	8.938
	2.00	2.250	2.625	0.875	1.000	2.250	2.000	0.688	1-1/2-12	6.375	2.000	4.313	0.375	3.188	9.063
12.00	2.00	2.250	2.625	0.875	1.000	2.250	2.000	0.688	1-1/2-12	6.875	2.000	4.813	0.375	3.188	9.563
	2.50	3.000	3.125	1.000	1.000	2.250	2.000	0.688	1-7/8-12	6.875	2.500	4.813	0.500	3.438	9.813

Table 2 MODELS D, C, DG AND CJ FLANGE MOUNT DIMENSIONS

BORE	ROD DIAMETER	E	F	FB	FH	R	RM	TE	TF	UF	W	ZF
1.50	0.63	2.000	0.375	0.313	0.375	1.438	-	-	2.750	3.375	0.625	5.000
	1.00	2.000	0.375	0.313	0.375	1.438	-	-	2.750	3.375	1.000	5.375
2.00	0.63	2.500	0.375	0.375	0.375	1.848	-	-	3.375	4.125	0.625	5.000
	1.00	2.500	0.375	0.375	0.375	1.848	-	-	3.375	4.125	1.000	5.375
2.50	0.63	3.000	0.375	0.375	0.375	2.188	-	-	3.875	4.625	0.625	5.125
	1.00	3.000	0.375	0.375	0.375	2.188	-	-	3.875	4.625	1.000	5.500
3.25	1.00	3.750	0.625	0.438	0.625	2.766	-	-	4.688	5.500	0.750	6.250
	1.38	3.750	0.625	0.438	0.625	2.766	-	-	4.688	5.500	1.000	6.500
4.00	1.00	4.500	0.625	0.438	0.625	3.328	-	-	5.438	6.250	0.750	6.250
	1.38	4.500	0.625	0.438	0.625	3.328	-	-	5.438	6.250	1.000	6.500
5.00	1.00	5.500	0.625	0.563	0.625	4.100	-	-	6.625	7.625	0.750	6.500
	1.38	5.500	0.625	0.563	0.625	4.100	-	-	6.625	7.625	1.000	6.750
6.00	1.38	6.500	0.625	0.563	0.750	4.875	-	-	7.625	8.625	0.875	7.375
	1.75	6.500	0.625	0.563	0.750	4.875	-	-	7.625	8.625	1.125	7.625
8.00	1.38	8.500	0.625	0.688	N/A	N/A	3.500	7.570	N/A	N/A	1.625	6.750
	1.75	8.500	0.625	0.688	N/A	N/A	3.500	7.570	N/A	N/A	1.875	7.000
10.00	1.75	10.625	0.625	0.813	N/A	N/A	3.500	9.400	N/A	N/A	1.875	8.250
	2.00	10.625	0.750	0.813	N/A	N/A	5.000	9.400	N/A	N/A	2.000	8.375
12.00	2.00	12.750	0.750	0.813	N/A	N/A	5.000	11.100	N/A	N/A	2.000	8.875
	2.50	12.750	0.750	0.813	N/A	N/A	5.000	11.100	N/A	N/A	2.250	9.125

MODEL E (NFPA MP1)

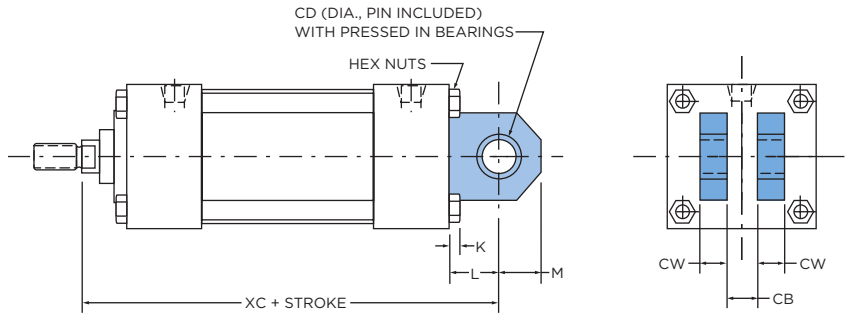

MODEL HE (NFPA MP2) 1.50" - 6.00" BORES

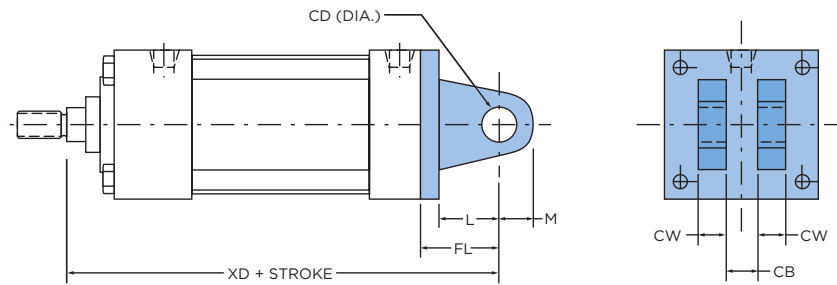

MODEL E4 (NFPA MP4) 1.50" - 6.00" BORES

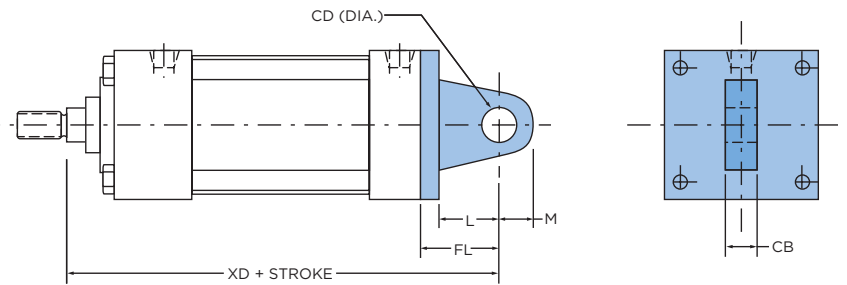

BASIC DIMENSIONS

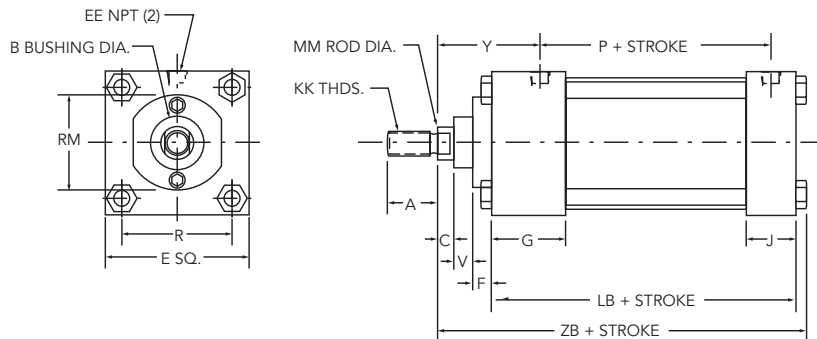

CLEVIS AND EYE MOUNT CYLINDERS

1.50" THROUGH 12.00" BORE

Table 1 BASIC DIMENSIONS STANDARD & OVERSIZE RODS

BORE	ROD DIAMETER	A	B	C	E	EE	F	G	J	KK	LB	MM	P	R	RM	V	Y	ZB
1.50	0.63	0.750	1.125	0.375	2.000	0.375	0.375	1.500	1.000	7/16-20	3.625	0.625	2.375	1.438	2.00	0.250	1.875	4.875
	1.00	1.125	1.500	0.500	2.000	0.375	0.375	1.500	1.000	3/4-16	3.625	1.000	2.375	1.438	2.00	0.500	2.250	5.250
2.00	0.63	0.750	1.125	0.375	2.500	0.375	0.375	1.500	1.000	7/16-20	3.625	0.625	2.375	1.844	2.00	0.250	1.875	4.938
	1.00	1.125	1.500	0.500	2.500	0.375	0.375	1.500	1.000	3/4-16	3.625	1.000	2.375	1.844	2.50	0.500	2.250	5.313
2.50	0.63	0.750	1.125	0.375	3.000	0.375	0.375	1.500	1.000	7/16-20	3.750	0.625	2.500	2.188	2.00	0.250	1.875	5.063
	1.00	1.125	1.500	0.500	3.000	0.375	0.375	1.500	1.000	3/4-16	3.750	1.000	2.500	2.188	3.00	0.500	2.250	5.438
3.25	1.00	1.125	1.500	0.500	3.750	0.500	0.625	1.750	1.250	3/4-16	4.250	1.000	2.750	2.766	2.75	0.250	2.375	6.000
	1.38	1.625	2.000	0.625	3.750	0.500	0.625	1.750	1.250	1-14	4.250	1.000	1.375	2.766	3.75	0.375	2.625	6.250
4.00	1.00	1.125	1.500	0.500	4.500	0.500	0.625	1.750	1.250	3/4-16	4.250	1.000	2.750	3.320	2.75	0.250	2.375	6.000
	1.38	1.625	2.000	0.625	4.500	0.500	0.625	1.750	1.250	1-14	4.250	1.000	1.375	3.320	3.50	0.375	2.625	6.250
5.00	1.00	1.125	1.500	0.500	5.500	0.500	0.625	1.750	1.250	3/4-16	4.500	1.000	3.000	4.100	2.75	0.250	2.375	6.313
	1.38	1.625	2.000	0.625	5.500	0.500	0.625	1.750	1.250	1-14	4.500	1.000	1.375	4.100	3.50	0.375	2.625	6.563
6.00	1.38	1.625	2.000	0.625	6.500	0.750	0.625	2.000	1.500	1-14	5.000	1.375	3.250	4.875	3.50	0.375	2.750	7.063
	1.75	2.000	2.375	0.750	6.500	0.750	0.625	2.000	1.500	1-1/4-12	5.000	1.750	3.250	4.875	3.50	0.500	3.000	7.313
8.00	1.38	1.625	2.000	0.625	8.500	0.750	0.625	2.000	1.500	1-14	5.125	1.375	3.375	6.438	3.50	0.375	2.750	7.313
	1.75	2.000	2.375	0.750	8.500	0.750	0.625	2.000	1.500	1-1/4-12	5.125	1.750	3.375	6.438	3.50	0.500	3.000	7.563
10.00	1.75	2.000	2.375	0.750	10.625	1.000	0.625	2.250	2.000	1-1/4-12	6.375	1.750	4.313	7.922	3.50	0.500	3.063	8.938
	2.00	2.250	2.625	0.875	10.625	1.000	0.750	2.250	2.000	1-1/2-12	6.375	2.000	4.313	7.922	5.00	0.375	3.188	9.063
12.00	2.00	2.250	2.625	0.875	12.750	1.000	0.750	2.250	2.000	1-1/2-12	6.875	2.000	4.813	9.400	5.00	0.375	3.188	9.563
	2.50	3.000	3.125	1.000	12.750	1.000	0.750	2.250	2.000	1-7/8-12	6.875	2.500	4.813	9.400	5.00	0.500	3.438	9.813

Table 2 MODEL E, HE CLEVIS MOUNT AND MODEL E4 EYE MOUNT DIMENSIONS

BORE	ROD DIAMETER	CB	CD	CW	FL	K	L	M	XC	XD
1.50	0.63	0.750	0.500	0.500	1.125	N/A	0.750	0.625	5.375	5.750
	1.00	0.750	0.500	0.500	1.125	N/A	0.750	0.625	5.750	6.125
2.00	0.63	0.750	0.500	0.500	1.125	N/A	0.750	0.625	5.375	5.750
	1.00	0.750	0.500	0.500	1.125	N/A	0.750	0.625	5.750	6.125
2.50	0.63	0.750	0.500	0.500	1.125	N/A	0.750	0.625	5.500	5.875
	1.00	0.750	0.500	0.500	1.125	N/A	0.750	0.625	5.875	6.250
3.25	1.00	1.250	0.750	0.625	1.875	0.375	1.250	0.875	6.875	7.500
	1.38	1.250	0.750	0.625	1.875	0.375	1.250	0.875	7.125	7.750
4.00	1.00	1.250	0.750	0.625	1.875	0.375	1.250	0.875	6.875	7.500
	1.38	1.250	0.750	0.625	1.875	0.375	1.250	0.875	7.125	7.750
5.00	1.00	1.250	0.750	0.625	1.875	0.438	1.250	0.875	7.125	7.750
	1.38	1.250	0.750	0.625	1.875	0.438	1.250	0.875	7.375	8.000
6.00	1.38	1.500	1.000	0.750	2.250	0.438	1.500	1.000	8.125	8.875
	1.75	1.500	1.000	0.750	2.250	0.438	1.500	1.000	8.375	9.125
8.00	1.38	1.500	1.000	0.750	N/A	0.563	1.500	1.000	8.250	N/A
	1.75	1.500	1.000	0.750	N/A	0.563	1.500	1.000	8.500	N/A
10.00	1.75	2.000	1.375	1.000	N/A	0.688	2.125	1.375	10.375	N/A
	2.00	2.000	1.375	1.000	N/A	0.688	2.125	1.375	10.500	N/A
12.00	2.00	2.500	1.750	1.250	N/A	0.688	2.250	1.750	11.125	N/A
	2.50	2.500	1.750	1.250	N/A	0.688	2.250	1.750	11.375	N/A

Clevis pins are provided with pivot mounts.

MODEL AP (NFPA MS1) 1.50" - 8.00" BORES

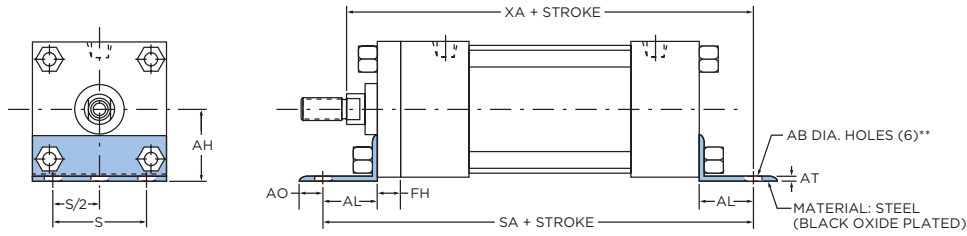

MODEL A (NFPA MS2) 1.50" - 8.00" BORES

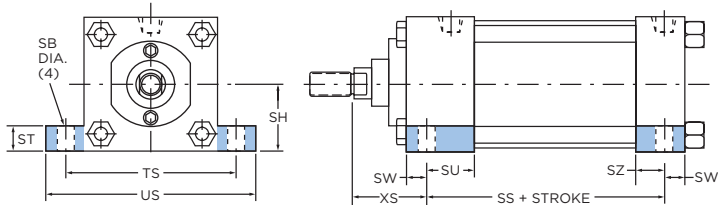

MODEL S (NFPA MS4)

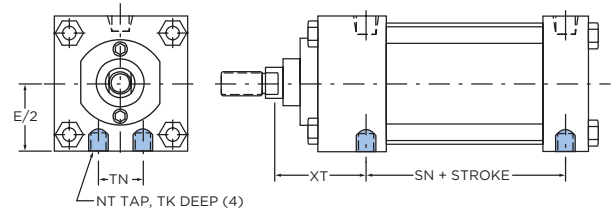

MODEL H (NO MOUNT)

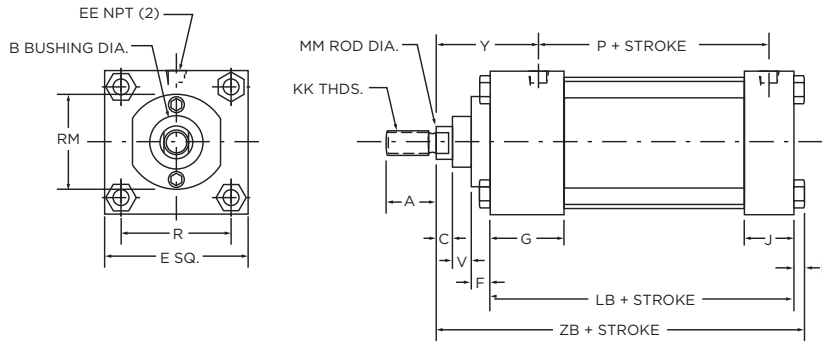

Table 1 BASIC DIMENSIONS STANDARD & OVERSIZE RODS

BORE	ROD DIAMETER	A	B	C	E	EE	F	G	J	K	KK	LB	MM	P	R	RM	V	Y	ZB
1.50	0.63	0.750	1.125	0.375	2.000	0.375	0.375	1.500	1.000	0.250	7/16-20	3.625	0.625	2.375	1.438	2.00	0.250	1.875	4.875
	1.00	1.125	1.500	0.500	2.000	0.375	0.375	1.500	1.000	0.250	3/4-16	3.625	1.000	2.375	1.438	2.00	0.500	2.250	5.250
2.00	0.63	0.750	1.125	0.375	2.500	0.375	0.375	1.500	1.000	0.313	7/16-20	3.625	0.625	2.375	1.844	2.00	0.250	1.875	4.938
	1.00	1.125	1.500	0.500	2.500	0.375	0.375	1.500	1.000	0.313	3/4-16	3.625	1.000	2.375	1.844	2.50	0.500	2.250	5.313
2.50	0.63	0.750	1.125	0.375	3.000	0.375	0.375	1.500	1.000	0.313	7/16-20	3.750	0.625	2.500	2.188	2.00	0.250	1.875	5.063
	1.00	1.125	1.500	0.500	3.000	0.375	0.375	1.500	1.000	0.313	3/4-16	3.750	1.000	2.500	2.188	3.00	0.500	2.250	5.438
3.25	1.00	1.125	1.500	0.500	3.750	0.500	0.625	1.750	1.250	0.375	3/4-16	4.250	1.000	2.750	2.766	2.75	0.250	2.375	6.000
	1.38	1.625	2.000	0.625	3.750	0.500	0.625	1.750	1.250	0.375	1-14	4.250	1.000	1.375	2.766	3.75	0.375	2.625	6.250
4.00	1.00	1.125	1.500	0.500	4.500	0.500	0.625	1.750	1.250	0.375	3/4-16	4.250	1.000	2.750	3.320	2.75	0.250	2.375	6.000
	1.38	1.625	2.000	0.625	4.500	0.500	0.625	1.750	1.250	0.375	1-14	4.250	1.000	1.375	3.320	3.50	0.375	2.625	6.250
5.00	1.00	1.125	1.500	0.500	5.500	0.500	0.625	1.750	1.250	0.438	3/4-16	4.500	1.000	3.000	4.100	2.75	0.250	2.375	6.313
	1.38	1.625	2.000	0.625	5.500	0.500	0.625	1.750	1.250	0.438	1-14	4.500	1.000	1.375	4.100	3.50	0.375	2.625	6.563
6.00	1.38	1.625	2.000	0.625	6.500	0.750	0.625	2.000	1.500	0.438	1-14	5.000	1.375	3.250	4.875	3.50	0.375	2.750	7.063
	1.75	2.000	2.375	0.750	6.500	0.750	0.625	2.000	1.500	0.438	1-1/4-12	5.000	1.750	3.250	4.875	3.50	0.500	3.000	7.313
8.00	1.38	1.625	2.000	0.625	8.500	0.750	0.625	2.000	1.500	0.563	1-14	5.125	1.375	3.375	6.438	3.50	0.375	2.750	7.313
	1.75	2.000	2.375	0.750	8.500	0.750	0.625	2.000	1.500	0.563	1-1/4-12	5.125	1.750	3.375	6.438	3.50	0.500	3.000	7.563
10.00	1.75	2.000	2.375	0.750	10.625	1.000	0.625	2.250	2.000	0.688	1-1/4-12	6.375	1.750	4.313	7.922	3.50	0.500	3.063	8.938
	2.00	2.250	2.625	0.875	10.625	1.000	0.750	2.250	2.000	0.688	1-1/2-12	6.375	2.000	4.313	7.922	5.00	0.375	3.188	9.063
12.00	2.00	2.250	2.625	0.875	12.750	1.000	0.750	2.250	2.000	0.688	1-1/2-12	6.875	2.000	4.813	9.400	5.00	0.375	3.188	9.563
	2.50	3.000	3.125	1.000	12.750	1.000	0.750	2.250	2.000	0.688	1-7/8-12	6.875	2.500	4.813	9.400	5.00	0.500	3.438	9.813

ANGLE AND SIDE LUG MOUNT CYLINDERS

1.50" THROUGH 12.00" BORE

Table 2 MODEL AP ANGLE BASE MOUNT DIMENSIONS

BORE	ROD DIAMETER	AB	AH	AL	AO	AT	FH	S	SA ADD STROKE	XA ADD STROKE
1.50	0.63	0.438	1.188	1.000	0.375	0.188	0.375	1.250	6.000	5.625
	1.00	0.438	1.188	1.000	0.375	0.188	0.375	1.250	6.000	6.000
2.00	0.63	0.438	1.438	1.000	0.375	0.188	0.375	1.750	6.000	5.625
	1.00	0.438	1.438	1.000	0.375	0.188	0.375	1.750	6.000	6.000
2.50	0.63	0.438	1.625	1.000	0.375	0.188	0.375	2.250	6.125	5.750
	1.00	0.438	1.625	1.000	0.375	0.188	0.375	2.250	6.125	6.125
3.25	1.00	0.563	1.938	1.250	0.500	0.125	0.625	2.750	7.375	6.875
	1.38	0.563	1.938	1.250	0.500	0.125	0.625	2.750	7.375	7.125
4.00	1.00	0.563	2.250	1.250	0.500	0.125	0.625	3.500	7.375	6.875
	1.38	0.563	2.250	1.250	0.500	0.125	0.625	3.500	7.375	7.125
5.00	1.00	0.688	2.750	1.375	0.625	0.188	0.625	4.250	7.875	7.250
	1.38	0.688	2.750	1.375	0.625	0.188	0.625	4.250	7.875	7.500
6.00	1.38	0.813	3.250	1.375	0.625	0.188	0.750	5.250	8.500	8.000
	1.75	0.813	3.250	1.375	0.625	0.188	0.750	5.250	8.500	8.250
8.00	1.38	0.813	4.250	1.813	0.688	0.250	0.625*	7.125	8.750	8.563
	1.75	0.813	4.250	1.813	0.688	0.250	0.625*	7.125	8.750	8.813

* 3.50" diameter round retainer on 8.00" bore (AP BRACKET BOLTED DIRECTLY TO HEAD). ** 1.50" bore has four (4) AB diameter holes.

Table 3 MODEL A SIDE LUG BASE MOUNT DIMENSIONS

BORE	ROD DIAMETER	SB	SH	ST	SU	SW	SZ	TS	US	XS	SS ADD STROKE
1.50	0.63	0.438	1.000	0.500	1.125	0.375	0.625	2.750	3.500	1.375	2.875
	1.00	0.438	1.000	0.500	1.125	0.375	0.625	2.750	3.500	1.750	2.875
2.00	0.63	0.438	1.250	0.500	1.125	0.375	0.625	3.250	4.000	1.375	2.875
	1.00	0.438	1.250	0.500	1.125	0.375	0.625	3.250	4.000	1.750	2.875
2.50	0.63	0.438	1.500	0.500	1.125	0.375	0.625	3.750	4.500	1.375	3.000
	1.00	0.438	1.500	0.500	1.125	0.375	0.625	3.750	4.500	1.750	3.000
3.25	1.00	0.563	1.875	0.750	1.250	0.500	0.750	4.750	5.750	1.875	3.250
	1.38	0.563	1.875	0.750	1.250	0.500	0.750	4.750	5.750	2.125	3.250
4.00	1.00	0.563	2.250	0.750	1.250	0.500	0.750	5.500	6.500	1.875	3.250
	1.38	0.563	2.250	0.750	1.250	0.500	0.750	5.500	6.500	2.125	3.250
5.00	1.00	0.813	2.750	1.000	1.063	0.688	0.563	6.875	8.250	2.063	3.125
	1.38	0.813	2.750	1.000	1.063	0.688	0.563	6.875	8.250	2.313	3.125
6.00	1.38	0.813	3.250	1.000	1.313	0.688	0.813	7.875	9.250	2.313	3.625
	1.75	0.813	3.250	1.000	1.313	0.688	0.813	7.875	9.250	2.563	3.625
8.00	1.38	0.813	4.250	1.000	1.313	0.688	0.813	9.875	11.250	2.313	3.750
	1.75	0.813	4.250	1.000	1.313	0.688	0.813	9.875	11.250	2.563	3.750

Table 4 MODEL S BOTTOM TAPPED BASE MOUNT DIMENSIONS

BORE	ROD DIAMETER	E/2	NT	TK	TN	XT	SN ADD STROKE
1.50	0.63	1.000	1/4-20	0.375	0.625	1.938	2.250
	1.00	1.000	1/4-20	0.375	0.625	2.313	2.250
2.00	0.63	1.250	5/16-18	0.500	0.875	1.938	2.250
	1.00	1.250	5/16-18	0.500	0.875	2.313	2.250
2.50	0.63	1.500	3/8-16	0.625	1.250	1.938	2.3875
	1.00	1.500	3/8-16	0.625	1.250	2.313	2.3875
3.25	1.00	1.875	1/2-13	0.750	1.500	2.438	2.625
	1.38	1.875	1/2-13	0.750	1.500	2.688	2.625
4.00	1.00	2.250	1/2-13	0.750	2.063	2.438	2.625
	1.38	2.250	1/2-13	0.750	2.063	2.688	2.625
5.00	1.00	2.750	5/8-11	1.000	2.688	2.438	2.875
	1.38	2.750	5/8-11	1.000	2.688	2.688	2.875
6.00	1.38	3.250	3/4-10	1.125	3.250	2.813	3.125
	1.75	3.250	3/4-10	1.125	3.250	3.063	3.125
8.00	1.38	4.250	3/4-10	1.125	4.500	2.813	3.250
	1.75	4.250	3/4-10	1.125	4.500	3.063	3.250
10.00	1.75	5.313	1-8	1.500	5.500	3.125	4.125
	2.00	5.313	1-8	1.500	5.500	3.250	4.125
12.00	2.00	6.375	1-8	1.500	7.250	3.250	4.625
	2.50	6.375	1-8	1.500	7.250	3.500	4.625

MODEL FR (NFPA MT1)

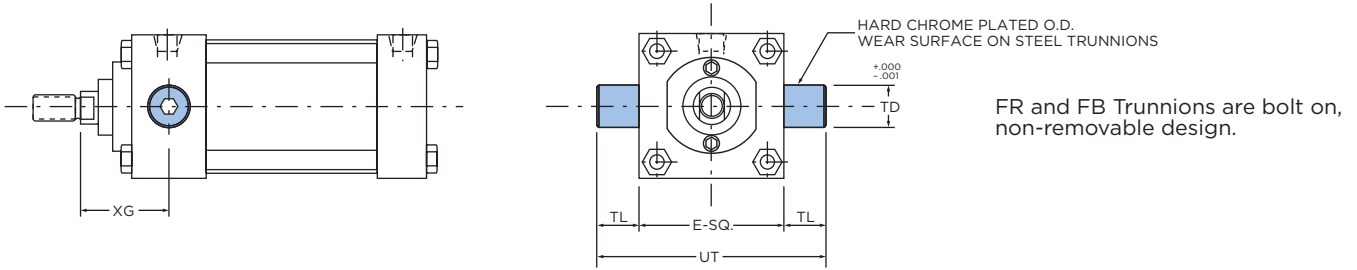

MODEL FB (NFPA MT2)

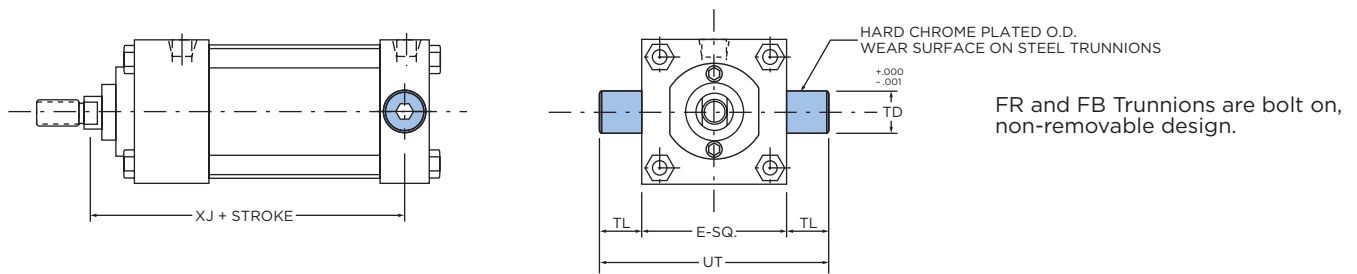

MODEL F (NFPA MT4)

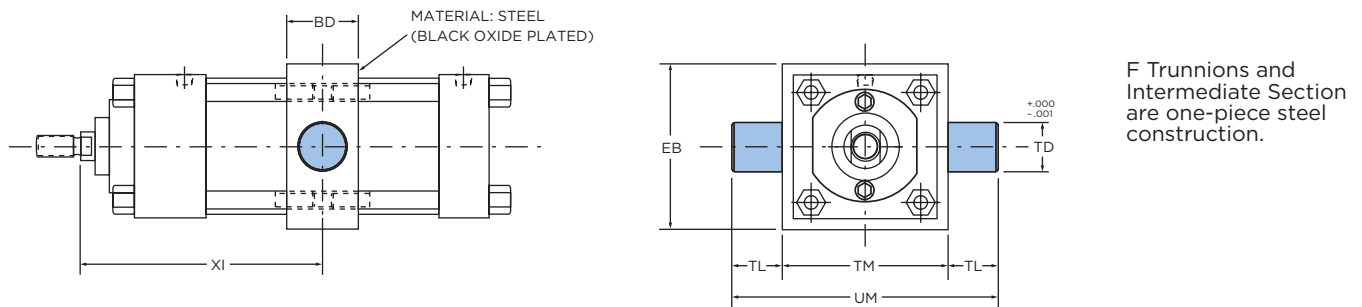

BASIC DIMENSIONS

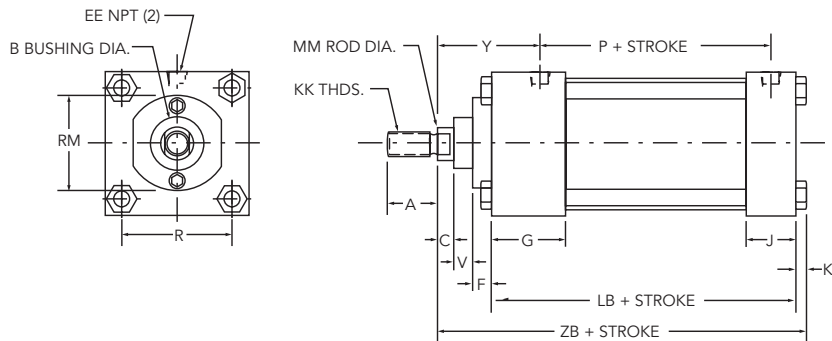

TRUNNION MOUNT CYLINDERS

1.50" THROUGH 8.00" BORE

Table 1 BASIC DIMENSIONS STANDARD & OVERSIZE RODS

BORE	ROD DIAMETER	A	B	C	EE	F	G	J	K	KK	LB	MM	P	R	RM	V	Y	ZB
1.50	0.63	0.750	1.125	0.375	0.375	0.375	1.500	1.000	0.250	7/16-20	3.625	0.625	2.375	1.438	2.00	0.250	1.875	4.875
	1.00	1.125	1.500	0.500	0.375	0.375	1.500	1.000	0.250	3/4-16	3.625	1.000	2.375	1.438	2.00	0.500	2.250	5.250
2.00	0.63	0.750	1.125	0.375	0.375	0.375	1.500	1.000	0.313	7/16-20	3.625	0.625	2.375	1.844	2.00	0.250	1.875	4.938
	1.00	1.125	1.500	0.500	0.375	0.375	1.500	1.000	0.313	3/4-16	3.625	1.000	2.375	1.844	2.50	0.500	2.250	5.313
2.50	0.63	0.750	1.125	0.375	0.375	0.375	1.500	1.000	0.313	7/16-20	3.750	0.625	2.500	2.188	2.00	0.250	1.875	5.063
	1.00	1.125	1.500	0.500	0.375	0.375	1.500	1.000	0.313	3/4-16	3.750	1.000	2.500	2.188	3.00	0.500	2.250	5.438
3.25	1.00	1.125	1.500	0.500	0.500	0.625	1.750	1.250	0.375	3/4-16	4.250	1.000	2.750	2.766	2.75	0.250	2.375	6.000
	1.38	1.625	2.000	0.625	0.500	0.625	1.750	1.250	0.375	1-14	4.250	1.000	1.375	2.766	3.75	0.375	2.625	6.250
4.00	1.00	1.125	1.500	0.500	0.500	0.625	1.750	1.250	0.375	3/4-16	4.250	1.000	2.750	3.320	2.75	0.250	2.375	6.000
	1.38	1.625	2.000	0.625	0.500	0.625	1.750	1.250	0.375	1-14	4.250	1.000	1.375	3.320	3.50	0.375	2.625	6.250
5.00	1.00	1.125	1.500	0.500	0.500	0.625	1.750	1.250	0.438	3/4-16	4.500	1.000	3.000	4.100	2.75	0.250	2.375	6.313
	1.38	1.625	2.000	0.625	0.500	0.625	1.750	1.250	0.438	1-14	4.500	1.000	1.375	4.100	3.50	0.375	2.625	6.563
6.00	1.38	1.625	2.000	0.625	0.750	0.625	2.000	1.500	0.438	1-14	5.000	1.375	3.250	4.875	3.50	0.375	2.750	7.063
	1.75	2.000	2.375	0.750	0.750	0.625	2.000	1.500	0.438	1-1/4-12	5.000	1.750	3.250	4.875	3.50	0.500	3.000	7.313
8.00	1.38	1.625	2.000	0.625	0.750	0.625	2.000	1.500	0.563	1-14	5.125	1.375	3.375	6.438	3.50	0.375	2.750	7.313
	1.75	2.000	2.375	0.750	0.750	0.625	2.000	1.500	0.563	1-1/4-12	5.125	1.750	3.375	6.438	3.50	0.500	3.000	7.563

Table 2 MODEL FR HEAD TRUNNION MOUNT AND MODEL FB CAP TRUNNION MOUNT DIMENSIONS

BORE	ROD DIAMETER	E	TD	TL	UT	XG	XJ ADD STROKE
1.50	0.63	2.000	1.000	1.000	4.000	1.750	4.125
	1.00	2.000	1.000	1.000	4.000	N/A*	4.500
2.00	0.63	2.500	1.000	1.000	4.500	1.750	4.125
	1.00	2.500	1.000	1.000	4.500	2.125	4.500
2.50	0.63	3.000	1.000	1.000	5.000	1.750	4.250
	1.00	3.000	1.000	1.000	5.000	2.125	4.625
3.25	1.00	3.750	1.000	1.000	5.750	2.250	5.000
	1.38	3.750	1.000	1.000	5.750	2.500	5.250
4.00	1.00	4.500	1.000	1.000	6.500	2.250	5.000
	1.38	4.500	1.000	1.000	6.500	2.500	5.250
5.00	1.00	5.500	1.000	1.000	7.500	2.250	5.250
	1.38	5.500	1.000	1.000	7.500	2.500	5.500
6.00	1.38	6.500	1.375	1.375	9.250	2.625	5.875
	1.75	6.500	1.375	1.375	9.250	2.875	6.125
8.00	1.38	8.500	1.375	1.375	11.250	2.625	6.000
	1.75	8.500	1.375	1.375	11.250	2.875	6.250

* No oversize rod available on 1.50" bore Model FR.

Table 3 MODEL F INTERMEDIATE TRUNNION MOUNT DIMENSIONS

BORE	BD	EB	TD	TL	TM	UM	XI
1.50	1.250	2.500	1.000	1.000	2.500	4.500	Customer to Specify
2.00	1.500	3.000	1.000	1.000	3.000	5.000	
2.50	1.500	3.500	1.000	1.000	3.500	5.500	
3.25	2.000	4.250	1.000	1.000	4.500	6.500	
4.00	2.000	5.000	1.000	1.000	5.250	7.250	
5.00	2.000	6.000	1.000	1.000	6.250	8.250	
6.00	2.000	7.000	1.375	1.375	7.625	10.375	
8.00	2.500	9.500	1.375	1.375	9.750	12.500	

Table 4 MODELS FR, FB AND F STANDARD CUSHION LOCATIONS

MOUNT	HEAD CUSHION	CAP CUSHION
FR	3	2
FB	2	3
F	2	2

Ports or cushions cannot be on same side as FR & FB Trunnions.

MODEL T (NFPA MX1)

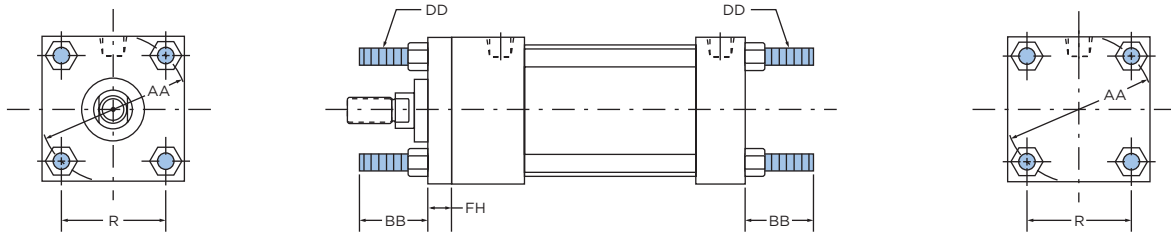

MODEL TB (NFPA MX2)

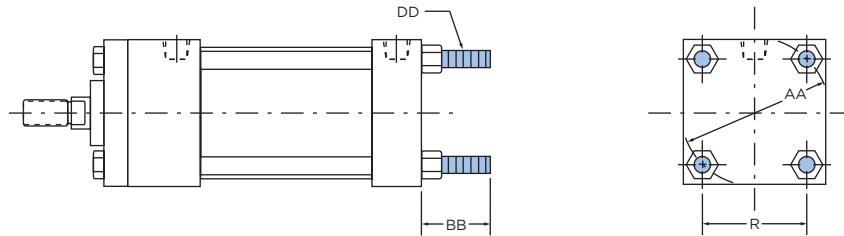

MODEL TR (NFPA MX3)

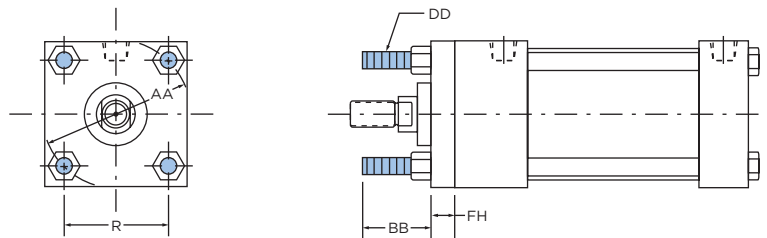

BASIC DIMENSIONS

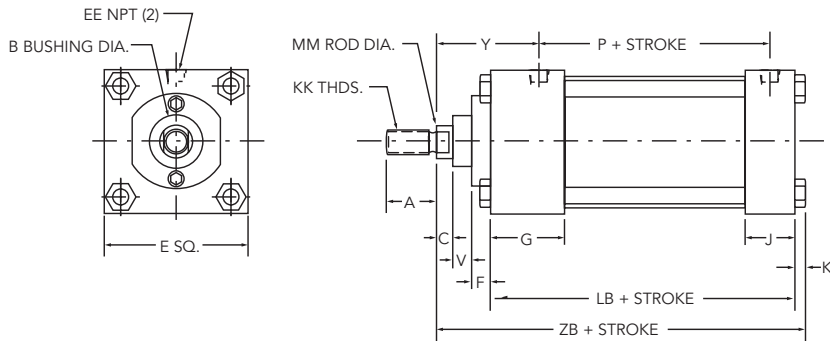

TIE ROD MOUNT CYLINDERS

1.50" THROUGH 12.00" BORE

Table 1 BASIC DIMENSIONS STANDARD & OVERSIZE RODS

BORE	ROD DIAMETER	A	B	C	E	EE	F	G	J	K	KK	LB	MM	P	RM	V	Y	ZB
1.50	0.63	0.750	1.125	0.375	2.000	0.375	0.375	1.500	1.000	0.250	7/16-20	3.625	0.625	2.375	2.00	0.250	1.875	4.875
	1.00	1.125	1.500	0.500	2.000	0.375	0.375	1.500	1.000	0.250	3/4-16	3.625	1.000	2.375	2.00	0.500	2.250	5.250
2.00	0.63	0.750	1.125	0.375	2.500	0.375	0.375	1.500	1.000	0.313	7/16-20	3.625	0.625	2.375	2.00	0.250	1.875	4.938
	1.00	1.125	1.500	0.500	2.500	0.375	0.375	1.500	1.000	0.313	3/4-16	3.625	1.000	2.375	2.50	0.500	2.250	5.313
2.50	0.63	0.750	1.125	0.375	3.000	0.375	0.375	1.500	1.000	0.313	7/16-20	3.750	0.625	2.500	2.00	0.250	1.875	5.063
	1.00	1.125	1.500	0.500	3.000	0.375	0.375	1.500	1.000	0.313	3/4-16	3.750	1.000	2.500	3.00	0.500	2.250	5.438
3.25	1.00	1.125	1.500	0.500	3.750	0.500	0.625	1.750	1.250	0.375	3/4-16	4.250	1.000	2.750	2.75	0.250	2.375	6.000
	1.38	1.625	2.000	0.625	3.750	0.500	0.625	1.750	1.250	0.375	1-14	4.250	1.000	1.375	3.75	0.375	2.625	6.250
4.00	1.00	1.125	1.500	0.500	4.500	0.500	0.625	1.750	1.250	0.375	3/4-16	4.250	1.000	2.750	2.75	0.250	2.375	6.000
	1.38	1.625	2.000	0.625	4.500	0.500	0.625	1.750	1.250	0.375	1-14	4.250	1.000	1.375	3.50	0.375	2.625	6.250
5.00	1.00	1.125	1.500	0.500	5.500	0.500	0.625	1.750	1.250	0.438	3/4-16	4.500	1.000	3.000	2.75	0.250	2.375	6.313
	1.38	1.625	2.000	0.625	5.500	0.500	0.625	1.750	1.250	0.438	1-14	4.500	1.000	1.375	3.50	0.375	2.625	6.563
6.00	1.38	1.625	2.000	0.625	6.500	0.750	0.625	2.000	1.500	0.438	1-14	5.000	1.375	3.250	3.50	0.375	2.750	7.063
	1.75	2.000	2.375	0.750	6.500	0.750	0.625	2.000	1.500	0.438	1-1/4-12	5.000	1.750	3.250	3.50	0.500	3.000	7.313
8.00	1.38	1.625	2.000	0.625	8.500	0.750	0.625	2.000	1.500	0.563	1-14	5.125	1.375	3.375	3.50	0.375	2.750	7.313
	1.75	2.000	2.375	0.750	8.500	0.750	0.625	2.000	1.500	0.563	1-1/4-12	5.125	1.750	3.375	3.50	0.500	3.000	7.563
10.00	1.75	2.000	2.375	0.750	10.625	1.000	0.625	2.250	2.000	0.688	1-1/4-12	6.375	1.750	4.313	3.50	0.500	3.063	8.938
	2.00	2.250	2.625	0.875	10.625	1.000	0.750	2.250	2.000	0.688	1-1/2-12	6.375	2.000	4.313	5.00	0.375	3.188	9.063
12.00	2.00	2.250	2.625	0.875	12.750	1.000	0.750	2.250	2.000	0.688	1-1/2-12	6.875	2.000	4.813	5.00	0.375	3.188	9.563
	2.50	3.000	3.125	1.000	12.750	1.000	0.750	2.250	2.000	0.688	1-7/8-12	6.875	2.500	4.813	5.00	0.500	3.438	9.813

Table 2 MODELS T, TB AND TR TIE ROD EXTENDED MOUNT DIMENSIONS

BORE	ROD DIAMETER	AA	BB	DD	FH	R
1.50	0.63	2.020	1.000	1/4-28	0.375	1.430
	1.00	2.020	1.000	1/4-28	0.375	1.430
2.00	0.63	2.600	1.125	5/16-24	0.375	1.840
	1.00	2.600	1.125	5/16-24	0.375	1.840
2.50	0.63	3.100	1.125	5/16-24	0.375	2.190
	1.00	3.100	1.125	5/16-24	0.375	2.190
3.25	1.00	3.900	1.375	3/8-24	0.625	2.760
	1.38	3.900	1.375	3/8-24	0.625	2.760
4.00	1.00	4.700	1.375	3/8-24	0.625	3.320
	1.38	4.700	1.375	3/8-24	0.625	3.320
5.00	1.00	5.800	1.813	1/2-20	0.625	4.100
	1.38	5.800	1.813	1/2-20	0.625	4.100
6.00	1.38	6.900	1.813	1/2-20	0.750	4.880
	1.75	6.900	1.813	1/2-20	0.750	4.880
8.00	1.38	9.100	**2.313	5/8-18	*0.625	6.440
	1.75	9.100	**2.313	5/8-18	*0.625	6.440
10.00	1.75	11.200	**2.688	3/4-16	*0.625	7.920
	2.00	11.200	**2.688	3/4-16	*0.750	7.920
12.00	2.00	13.300	**2.688	3/4-16	*0.750	9.400
	2.50	13.300	**2.688	3/4-16	*0.750	9.400

* T & TR have full square bushing retainer on 1.50"- 6.00" bores, round retainers on 8.00"-12.00" bores.

** BB dimension from face of head.

DOUBLE ROD END MODELS

BENEFITS:

- Standard and Oversize Piston Rods available.
- Full range of Standard Options.
- Durable design. Full Rod Bearing at each end of cylinder.
- Available in Models A, AP, D, DG, F, FR, S, T and TR.

Double rod end models are designated by letter "X" preceding the model identification.

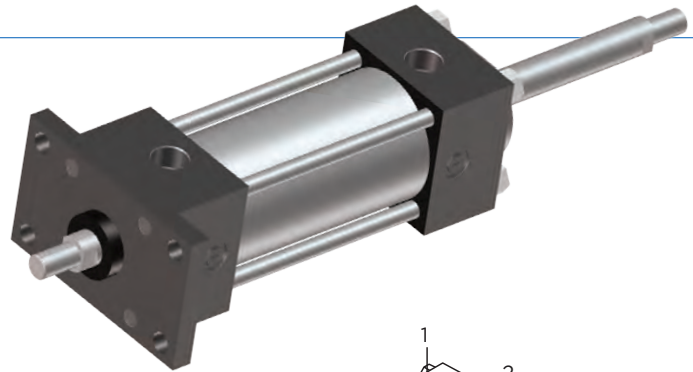

Standard Port And Cushion Adjustment Positions

- Ports - Position 1
- Cushion Adjustment - Position 2
- Specify Non-Standard Positions When Ordering

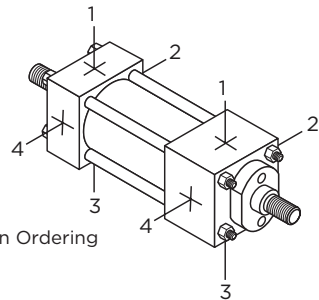

MODEL XH (NO MOUNT)

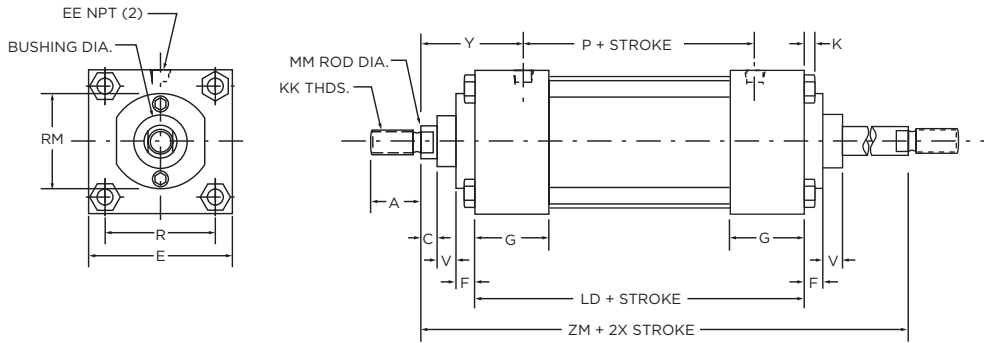

Table 1 BASIC DIMENSIONS DOUBLE ROD END STANDARD & OVERSIZE RODS

BORE	ROD DIAMETER	A	B	C	E	EE	F	G	K	KK	LD	MM	P	R	RM	V	Y	ZM
1.50	0.63	0.750	1.125	0.375	2.000	0.375	0.375	1.500	0.250	7/16-20	4.125	0.625	2.375	1.430	2.00	0.250	1.875	6.125
	1.00	1.125	1.500	0.500	2.000	0.375	0.375	1.500	0.250	3/4-16	4.125	1.000	2.375	1.430	2.00	0.500	2.250	6.875
2.00	0.63	0.750	1.125	0.375	2.500	0.375	0.375	1.500	0.313	7/16-20	4.125	0.625	2.375	1.844	2.00	0.250	1.875	6.125
	1.00	1.125	1.500	0.500	2.500	0.375	0.375	1.500	0.313	3/4-16	4.125	1.000	2.375	1.844	2.50	0.500	2.250	6.875
2.50	0.63	0.750	1.125	0.375	3.000	0.375	0.375	1.500	0.313	7/16-20	4.250	0.625	2.500	2.188	2.00	0.250	1.875	6.250
	1.00	1.125	1.500	0.500	3.000	0.375	0.375	1.500	0.313	3/4-16	4.250	1.000	2.500	2.188	3.00	0.500	2.250	7.000
3.25	1.00	1.125	1.500	0.500	3.750	0.500	0.625	1.750	0.375	3/4-16	4.750	1.000	2.750	2.760	2.75	0.250	2.375	7.500
	1.38	1.625	2.000	0.625	3.750	0.500	0.625	1.750	0.375	1-14	4.750	1.375	2.750	2.760	3.75	0.375	2.625	8.000
4.00	1.00	1.125	1.500	0.500	4.500	0.500	0.625	1.750	0.375	3/4-16	4.750	1.000	2.750	3.320	2.75	0.250	2.375	7.500
	1.38	1.625	2.000	0.625	4.500	0.500	0.625	1.750	0.375	1-14	4.750	1.375	2.750	3.320	3.50	0.375	2.625	8.000
5.00	1.00	1.125	1.500	0.500	5.500	0.500	0.625	1.750	0.438	3/4-16	5.000	1.000	3.000	4.100	2.75	0.250	2.375	7.750
	1.38	1.625	2.000	0.625	5.500	0.500	0.625	1.750	0.438	1-14	5.000	1.375	3.000	4.100	3.50	0.375	2.625	8.250
6.00	1.38	1.625	2.000	0.625	6.500	0.750	0.625	2.000	0.438	1-14	5.500	1.375	3.250	4.875	3.50	0.375	2.750	8.750
	1.75	2.000	2.375	0.750	6.500	0.750	0.625	2.000	0.438	1-1/4-12	5.500	1.750	3.250	4.875	3.50	0.500	3.000	9.250
8.00	1.38	1.625	2.000	0.625	8.500	0.750	0.625	2.000	0.563	1-14	5.625	1.375	3.375	6.438	3.50	0.375	2.750	8.875
	1.75	2.000	2.375	0.750	8.500	0.750	0.625	2.000	0.563	1-1/4-12	5.625	1.750	3.375	6.438	3.50	0.500	3.000	9.375
10.00	1.75	2.000	2.375	0.750	10.625	1.000	0.625	2.250	0.688	1-1/4-12	6.625	1.750	4.313	7.922	3.50	0.500	3.060	10.375
	2.00	2.250	2.625	0.875	10.625	1.000	0.750	2.250	0.688	1-1/2-12	6.625	2.000	4.313	7.922	5.00	0.375	3.188	10.625
12.00	2.00	2.250	2.625	0.875	12.750	1.000	0.750	2.250	0.688	1-1/2-12	7.125	2.000	4.813	9.400	5.00	0.375	3.188	11.125
	2.50	3.000	3.125	1.000	12.750	1.000	0.750	2.250	0.688	1-7/8-12	7.125	2.500	4.813	9.400	5.00	0.500	3.438	11.625

BASIC CYLINDER FORCE CHART

BORE	ROD DIA.	STROKE TYPE	EFFECTIVE PISTON AREA	POUNDS OF FORCE AT PSI						CU. FT. DISPLACEMENT PER IN. OF STROKE
				60	80	100	200	250	400	
1.50	ALL	PUSH	1.767	106	142	177	353	442	706	.00102
	0.63	PULL	1.460	88	117	146	292	365	584	.00084
	1.00	PULL	0.982	59	79	98	196	246	392	.00057
2.00	ALL	PUSH	3.142	188	251	314	628	785	1256	.00182
	0.63	PULL	2.835	170	227	284	567	708	1134	.00164
	1.00	PULL	2.357	141	189	236	471	589	942	.00136
2.50	ALL	PUSH	4.909	295	393	491	981	1227	1962	.00284
	0.63	PULL	4.602	276	368	460	920	1150	1840	.00266
	1.00	PULL	4.124	247	330	412	825	1031	1650	.00239
3.25	ALL	PUSH	8.296	498	664	830	1659	2074	3318	.00480
	1.00	PULL	7.511	451	601	751	1502	1877	3004	.00435
	1.38	PULL	6.811	409	545	681	1362	1702	2724	.00394
4.00	ALL	PUSH	12.566	754	1005	1257	2513	3141	5026	.00727
	1.00	PULL	11.781	707	942	1178	2356	2945	4712	.00682
	1.38	PULL	11.081	665	886	1108	2216	2770	4432	.00641
5.00	ALL	PUSH	19.635	1178	1571	1964	3927	4908	7854	.01136
	1.00	PULL	18.850	1131	1508	1885	3770	4712	7540	.01090
	1.38	PULL	18.150	1089	1452	1815	3630	4537	7260	.01050
6.00	ALL	PUSH	28.274	1696	2262	2827	5655	7068	11310	.01636
	1.38	PULL	26.789	1607	2144	2679	5358	6697	10716	.01550
	1.75	PULL	25.869	1552	2070	2587	5174	6467	10348	.01497
8.00	ALL	PUSH	50.265	3016	4021	5026	10053	12566	20106	.02908
	1.38	PULL	48.780	2927	3902	4878	9756	12195	19512	.02832
	1.75	PULL	47.860	2872	3829	4786	9572	11965	19144	.02770
10.00	ALL	PUSH	78.540	4712	6283	7854	15708	19635	31416	.04545
	1.75	PULL	76.130	4568	6090	7613	15226	19032	30452	.04406
	2.00	PULL	75.400	4524	6032	7540	15080	18850	30160	.04363
12.00	ALL	PUSH	113.098	6786	9048	11310	22620	28275	45239	.06545
	2.00	PULL	109.956	6597	8796	10996	21992	27489	43982	.06363
	2.50	PULL	108.189	6491	8655	10819	21638	27047	43276	.06261

* Theoretical force. Actual force will be reduced by friction.

TORQUE CHARTS

CYLINDER TIE RODS

CYLINDER BORE	TIE ROD THREAD SIZE	TORQUE IN FT.-LBS.
1.50	1/4 - 28	7
2.00	5/16 - 24	12
2.50	5/16 - 24	14
3.25	3/8 - 24	30
4.00	3/8 - 24	35
5.00	1/2 - 20	45
6.00	1/2 - 20	50
8.00	5/8 - 18	125
10.00	3/4 - 16	125
12.00	3/4 - 16	125

RETAINER SCREWS

CYLINDER BORE	SIZE	TORQUE IN FT.-LBS.
2.00 - 2.50	#10-32 S.H.C.S.	5
3.25 - 12.00	1/4-28 S.H.C.S.	12

Tighten cylinders using an "X" tightening pattern on tie rods.

ROD CLEVIS DIMENSIONS									
PART NUMBER	MAX LOAD (TENSION) RATED IN LBS	CB	CD (DIA.)	CE	CH	CW	ER (RADIUS)	KK	L
2834L59-A	2950	0.750	0.500	1.500	1.000	0.500	0.500	7/16-20	0.750
2835L59-A	11200	1.250	0.750	2.375	1.250	0.625	0.750	3/4-16	1.250
2836L59-A	19500	1.500	1.000	3.125	1.500	0.750	1.000	1-14	1.500
2837L59-A	26800	2.000	1.375	4.125	2.000	1.000	1.375	1-1/4-12	2.125
2838L59-A	39500	2.500	1.750	4.500	2.375	1.250	1.750	1-1/2-12	2.250
2839L59-A	56000	2.500	2.000	5.500	3.000	1.250	2.000	1-7/8-12	2.500

ROD CLEVIS

**MATERIAL: CAST STEEL
FINISH: BLACK OXIDE**

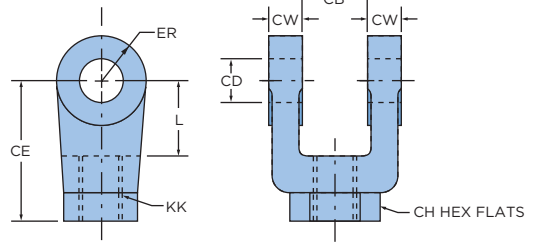

(Clevis Pins sold separately from Rod Clevises)
Note: When using a Rod Clevis in combination with an Eye Bracket, the operating angle is limited to +/-75° from the bracket center line.

EYE BRACKET DIMENSIONS										
PART NUMBER	MAX LOAD (TENSION) RATED IN LBS	BA	CB	CD (DIA.)	DD	E	F	FL	L	M
2716L47-A	3375	1.625	0.750	0.500	0.406	2.500	0.375	1.125	0.750	0.500
2719L32-A	8400	2.563	1.250	0.750	0.531	3.500	0.625	1.875	1.250	0.750
2720L33-A	13500	3.250	1.500	1.000	0.656	4.500	0.750	2.250	1.500	1.000
2721L34-A	25000	3.813	2.000	1.375	0.656	5.000	0.875	3.000	2.125	1.375
2722L35-A	45000	4.938	2.500	1.750	0.906	6.500	0.875	3.125	2.250	1.750
2723L36-A	45000	5.750	2.500	2.000	1.063	7.500	1.000	3.500	2.500	2.000

EYE BRACKET

**MATERIAL: CAST STEEL
FINISH: BLACK OXIDE**

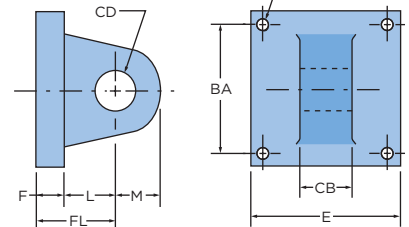

(Clevis Pins sold separately from Eye Brackets)

CLEVIS PIN (WITH COTTER PINS)			
PART NUMBER	CD (DIA.)	LH	LP
3222L47-1-A	0.500	2.250	1.938
3222L47-2-A	0.750	3.000	2.719
3222L47-3-A	1.000	3.500	3.219
3222L47-4-A	1.375	5.000	4.250
3222L47-5-A	1.750	6.000	5.500
3222L47-6-A	2.000	6.000	5.500

CLEVIS PIN (INCLUDES COTTER PIN)

**MATERIAL: 1045 CRS
FINISH: CHROME PLATED O.D.**

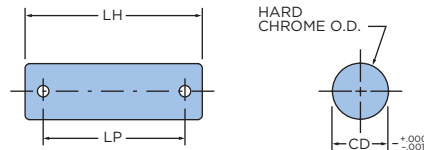

ROD EYE DIMENSIONS							
PART NUMBER	MAX LOAD (TENSION) RATED IN LBS	A	CA	CB	CD (DIA.)	ER (RADIUS)	KK
1810L59-A	2950	0.750	1.500	0.750	0.500	0.625	7/16-20
1812L59-A	8400	1.125	2.063	1.250	0.750	0.875	3/4-16
1813L59-A	13500	1.625	2.813	1.500	1.000	1.180	1-14
1814L59-A	24500	2.000	3.438	2.000	1.375	1.563	1-1/4-12
1815L59-A	39000	2.250	4.000	2.500	1.750	2.000	1-1/2-12
1817L59-A	45000	3.000	5.000	2.500	2.000	2.500	1-7/8-12

ROD EYE

**MATERIAL: 1018 CRS
FINISH: BLACK OXIDE**

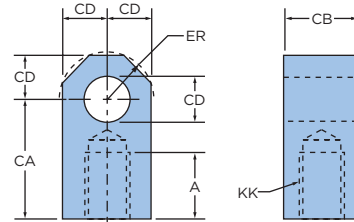

(Clevis Pins sold separately from Rod Eyes)
Note: When using a Rod Eye in combination with a Clevis Bracket, the operating angle is limited to +/-90° from the bracket center line.

CLEVIS BRACKET DIMENSIONS											
PART NUMBER	MAX LOAD (TENSION) RATED IN LBS	BA	CB	CD (DIA.)	CW	DD	E	F	FL	L	M
2683L47-A	4500	1.625	0.750	0.500	0.500	3/8-24	2.500	0.375	1.125	0.750	0.500
2684L47-A	8400	2.563	1.250	0.750	0.625	1/2-20	3.500	0.625	1.875	1.250	0.750
2685L47-A	13500	3.250	1.500	1.000	0.750	5/8-18	4.500	0.750	2.250	1.500	1.000
2686L47-A	34000	3.813	2.000	1.375	1.000	5/8-18	5.000	0.875	3.000	2.125	1.375
2687L47-A	54000	4.938	2.500	1.750	1.250	7/8-14	6.500	0.875	3.125	2.250	1.750
2688L47-A	89000	5.750	2.500	2.000	1.250	1-14	7.500	1.000	3.500	2.500	2.000

CLEVIS BRACKET

**MATERIAL: CAST STEEL
FINISH: BLACK OXIDE**

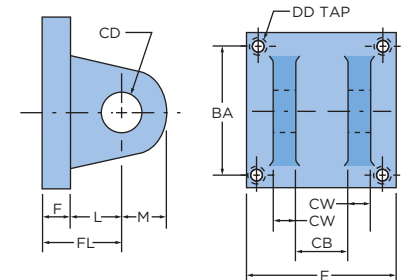

(Clevis Pins sold separately from Clevis Brackets)

REED SWITCH WITH BRACKET

Miniature Reed Switch, 24" (24 AWG Wire, PVC Jacket)
 Plain Cable Lead, Circuit Protection (2 wire Switch)

BORE SIZE	PART NUMBER
1.50" - 2.50"	19456E00-1
3.25" - 12.00"	19456E00-2

Contacts SPST Form A (Normally Open)
Contact Rating 10 Watts Max.
Input Voltage 120 Volts Max. (AC or DC)
Maximum Load Current 150 mA Max.
Actuating Time Average 1.0 millisecond
LED Indicator High Luminescence Housing
Temperature Range -4°F to 158°F (-20°C to 70°C)
Protection Rating IP67

Circuit Protection

Varistor 138 Volts
Choke 680 μ H



NOTE: The circuit protection consists of a Varistor and Choke arrangement. The Varistor will take transient & voltage spikes out of the line and is mounted in parallel with the switch. The Choke will disperse inrush currents (normally caused by long cable runs) and is mounted in series with the switch.

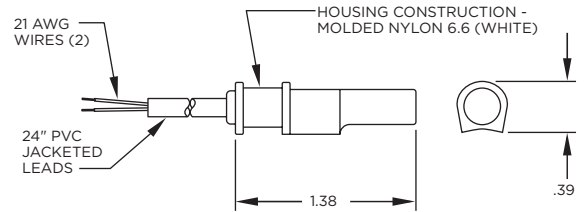

WIRING DIAGRAM

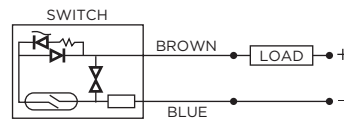

Miniature Reed Switch, Cable Type (2 Wire Switch)
Input Voltage 120 Volts Max. AC/DC
Maximum Load Current 150 mA Max.

SWITCH BRACKET

(For 1.50" Through 2.50" Bore Cylinders)
Bracket Construction: Molded Nylon 6 (Black) and Stainless Steel Hardware

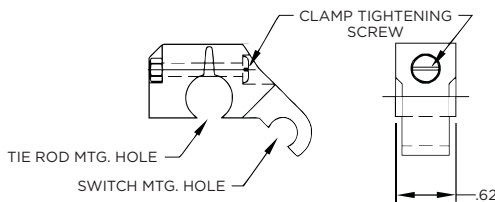

SWITCH BRACKET

(For 3.25" Through 12.00" Bore Cylinders)
Bracket Construction: Molded Nylon 6 (Black) and Stainless Steel Hardware

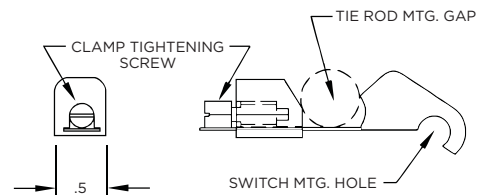

HOW TO ASSEMBLE SWITCH AND BRACKETS

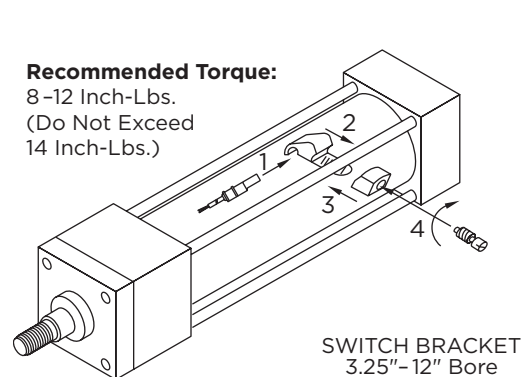
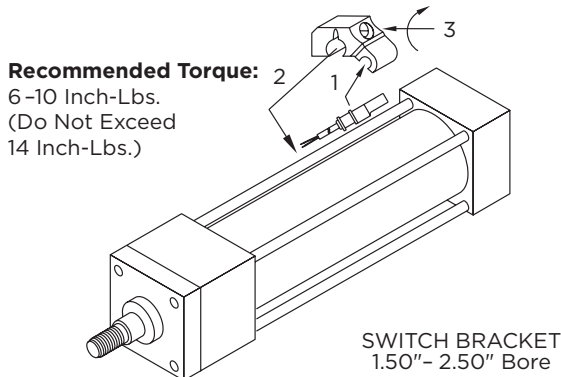

Specify Magnetic Piston option for ALL switch models when ordering cylinders.

EXTENDED PISTON ROD THREAD

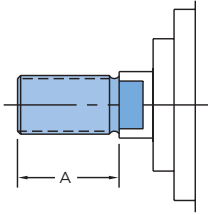

“A” refers to the length of piston rod thread.

Shorter than standard lengths can be furnished at no charge. Longer than standard lengths can be furnished at a nominal price adder.

EXTENDED PISTON ROD

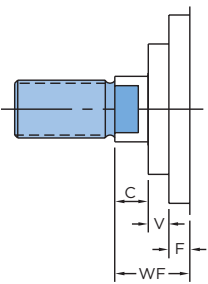

“WF” is commonly referred to as Piston Rod Extension.

Piston rods can be extended to any length up to 120” total piston rod length, including stroke portion. Cylinders with long “WF” lengths can be mounted away from obstacles or outside hazardous environments.

STUDED PISTON ROD

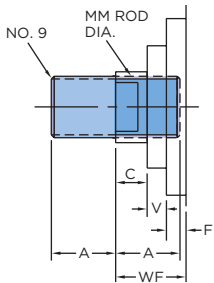

Type 9 combines the Type 5 female threaded rod end design and a case-hardened stud, with permanent Loctite®. When assembled, the Type 9 has the same dimensions as a Type 4 rod end.

This option is useful in applications that typically break standard Type 4 rod ends due to high load impacting.

SPECIAL ROD THREAD

NPAK can machine virtually any diameter and type of rod thread on the piston rod end. Standard NFPA rod threads are UNF (fine), class 2 threads. Common alternative choices are UNC (course) threads. Some uncommon thread choices are threads larger than the rod diameter. This is only possible by providing a Type 5 (female) rod end and making a stud with the larger rod thread.

NOTE: Unless otherwise specified, the rod thread will be standard catalog “A” dimension lengths.

METRIC ROD THREAD

ISO 6431 is a very popular European tie rod cylinder design. Equipment that is imported from outside the United States typically will contain metric tie-rod cylinders. In general, ISO 6431 tie rod cylinders are not as robust as NFPA cylinder designs and some customers prefer to replace the metric cylinders with NFPA designs that will provide longer life.

NPAK can provide cylinders with metric piston rod end threads to assist customers in mating replacement cylinders to existing equipment.

OVERSIZE ROD



OVERSIZED PISTON ROD

STANDARD PISTON ROD

Applications requiring long strokes may require oversize piston rod diameters to prevent sagging or buckling. To determine the recommended rod diameter, refer to Chart 3 on page 93.

METALLIC ROD SCRAPER

Aggressively scrapes the piston rod, removing foreign material such as spatter, sprays and powders (brass construction).

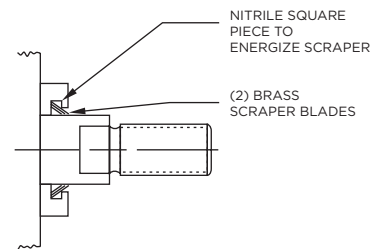

OPTIONS AND MODIFICATIONS

ROD COUPLER END

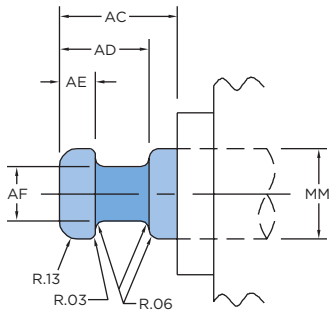

The Type 7 rod end was made popular in 3000 PSI hydraulic applications due to its versatility and high strength. Typically, a commercially available split flange end coupler and weld plate is used to connect the cylinder directly to the work that is being performed.

ROD DIAMETER (MM)	AC	AD	AE	AF
0.63	1.125	0.625	0.250	0.375
1.00	1.625	0.938	0.375	0.688
1.38	1.750	1.062	0.375	0.875
1.75	2.000	1.313	0.500	1.125
2.00	2.625	1.688	0.625	1.375
2.50	3.250	1.938	0.750	1.750

MAGNETIC PISTON

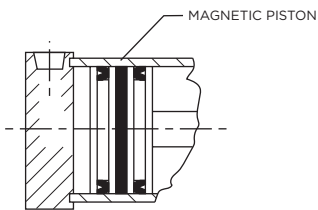

Magnetic Pistons are used in conjunction with NOPAK Reed Switches. (See page 89 for switches).

OPTIONAL PORT LOCATION

Optional port locations can be ordered simply by calling out the location numbers.

NOTE: When optional port locations are ordered, specify both port locations, even if one port is in the standard location.

- STANDARD PORT POSITIONS @ 1
- STANDARD CUSHION POSITIONS @ 2
- SPECIFY NON-STANDARD LOCATIONS WHEN ORDERING

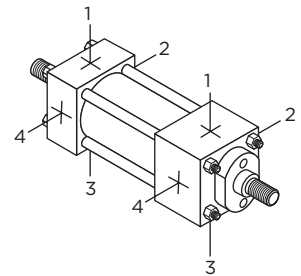

FLUOROCARBON SEALS

Type B Option contains two (2) Fluorocarbon U-Cup piston seals, Bushing O-Ring, rod seal and rod wiper.

Fluorocarbon seal material has an overall shorter seal life due to the higher wear rate inherent with the material. In general, Fluorocarbon seals should only be specified when temperatures exceed 200°F for prolonged periods of time or when there is a fluid compatibility issue with standard seals.

BENEFITS OF FLUOROCARBON SEALS:

- Higher temperature performance: 0°F to 400°F (-20°C to 200°C)
- Higher chemical resistance: Resists most wash down solutions

Many other seal materials are available. Contact NOPAK for proper seal material selection in tough applications or environments.

ELECTROLESS NICKEL

Electroless Nickel (EMS-201) plating was invented in 1946 and has gained worldwide commercial usage since 1964. Common usages include aircraft landing gear, automotive brake cylinder and components, fuel injector parts, gas turbine parts, spray nozzles for chemical applications and many electronic devices including hard drives.

The properties of Electroless Nickel contribute to the multitude of uses. The coating provides an attractive finish, while exhibiting high abrasion and corrosion resistance. Its ability to uniformly coat blind holes, threads, internal surfaces and sharp edges contributes to its effectiveness. It has a very high bonding strength to the base metal (100,000-200,000 PSI), so much so that gas turbines use electroless nickel plating as a base to braze broken blades to.

EMS-201 CYLINDER SPECIFICATIONS

EMS-201 PLATED PARTS:

Tube, Head, Cap, Bushing Retainer, Mounts (excluding FR/FB, which is hard chrome plated stainless steel).

OTHER COMPONENTS:

303/304 Stainless Steel: Tie Rods & Nuts, Retainer Screws, Piston Rod (hard chrome plated), Rod Bushing with PTFE Wear Band and Rod Wiper.

EMS-201 PLATING SPECIFICATIONS:

HIGH PHOSPHORUS	Highest corrosion resistant Electroless Nickel plating available
COMPOSITION:	87- 90% Nickel, 10 -13% Phosphorus
HARDNESS:	Rc 46-48
THICKNESS:	.0005" - .0007"
LUBRICITY:	Excellent (Similar to chrome)
COEFFICIENT OF FRICTION:	Low
FINISH:	Bright and very smooth

STAINLESS STEEL

Stainless Steel, when used in conjunction with Anodized Aluminum Heads, Caps and Tube, provides corrosion resistance in outdoor applications and wet environments.

Customize your cylinder by choosing from Stainless Steel Fasteners, Piston Rod or Tie Rods & Nuts.

Stainless Steel Piston Rod (Hard-Chrome Plated), Stainless Steel Fasteners, Stainless Steel Tie Rods & Nuts	Stainless Steel Cushion Needle (External Adjustment Components)
Stainless Steel Tie Rods and Nuts	Stainless Steel Fasteners (Bushing Retainer Screws)
Stainless Steel Piston Rod (Hard-Chrome Plated)	

STOP TUBE

Stop Tubes are designed to reduce the piston rod bushing stress to within the designed range of the bearing material. This will ensure proper cylinder performance, in any given application. Stop Tubes lower the cylinder bearing stress by adding length to the piston, which increases the overall length of the cylinder.

NOTE: NOPAK uses a double piston design for 2" and longer stop tubes.

STOP TUBE SELECTION

To determine the proper amount of stop tube for your application, you must first find the value of "D," which represents the "stroke, adjusted for mounting condition." Each mounting condition creates different levels of bushing stress, which have direct impact on the amount of stop tube required (see Chart 1).

Once the value of "D" is known, refer to Chart 2 for the recommended amount of stop tube.

To order a Stop Tube, add the stop tube prefix "ST=" and the length, to the end of your cylinder model number.

The effective stroke (ES) must be included when ordering.

CHART 1

Find the value of "D" for your application

NOTE: Measure "D" when cylinder is fully extended.

"D" = Stroke, adjusted for mounting condition

"S" = Actual cylinder stroke

"T" = Axial thrust (refer to Chart 3)

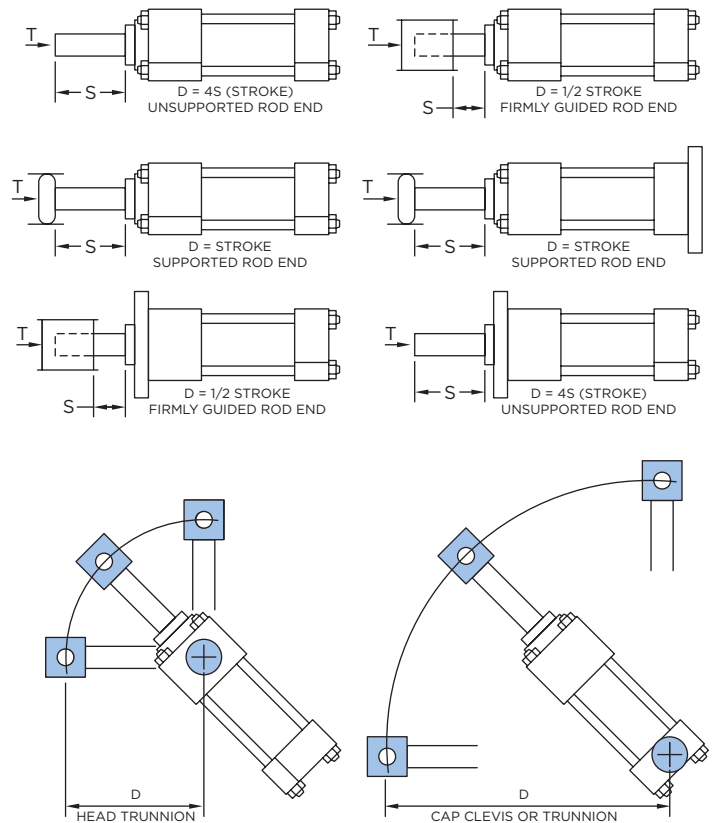

CHART 2

Using the value of "D," find the recommended amount of stop tube

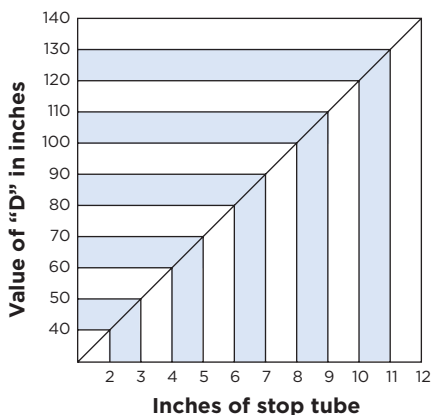

CHART 3

Rod size selection

