

Directional Control Valves

Hand, Foot and Solenoid

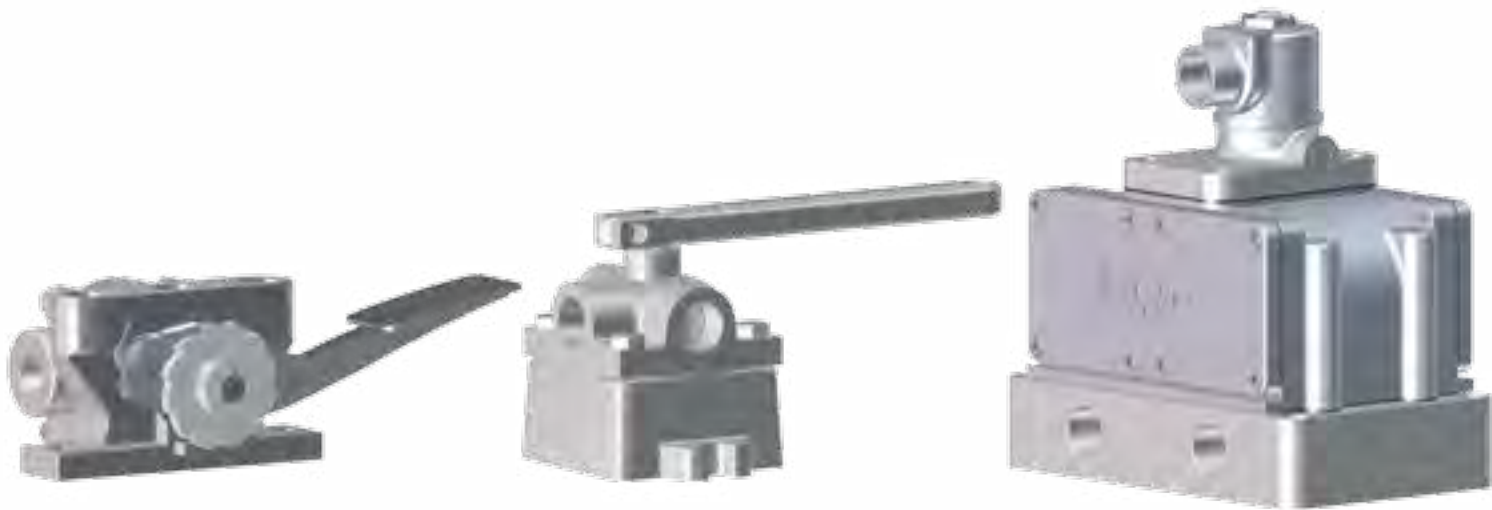

NOPAK

First in Manufacturing. Engineered to Last.

SERIES 310, 320, 410 & 420

HIGH SPEED, HIGH VOLUME NOPAK-MATIC SINGLE AND DOUBLE SOLENOID VALVES

FEATURES AND BENEFITS

“FLOW-DIRECTOR” PILOT HEAD – Simplifies piping and makes desired valve operation simple by piping to the proper port.

INTERCHANGEABLE PILOT HEADS – Any pilot head fits any valve, regardless of type or size.

SOLENOIDS – Low amperage, continuously rated industrial type with hardened plunger faces.

REPLACEABLE, SELF-CLEANING SEATS – Fast and inexpensive replacement of all seats. Poppets do not seat on valve body.

POSITIVE SEALING – Resilient, bonded poppet seals ensure leakproof operation and long life.

RAPID RESPONSE – Valve shifts in less than .05 of a second.

FULL FLOW – All passages oversized for minimum pressure drop through the valve (up to 1”).

NO SPRINGS – Piston-poppets shift with air pressure.

LIGHT WEIGHT, COMPACT – Aluminum used extensively for smaller overall dimensions. Every model has a clean, neat appearance that complements modern machine design. Base mounting is provided, but light weight of valves permits in-line mounting of largest valve.

CORROSION RESISTANT – All materials corrosion resistant.

PART INTERCHANGEABILITY – Design allows maximum part interchangeability from one valve to another and perfect “non-selected” fit of factory shipped maintenance parts.

SIMPLIFIED PIPING – Exclusive “Flow-Director” allows piping with fewer fittings...makes fewer valves adaptable to more applications. See page 157.

MANIFOLD MOUNTING – Multiple valves of the various series or sizes can be mounted on a common manifold requiring only one inlet and exhaust.

ADDITIONAL FEATURES

- Subplate mounted
- Splash- and dust-proof solenoid covers
- Manual solenoid pushbuttons
- Covers chained to valve
- Solenoid inoperative with covers removed

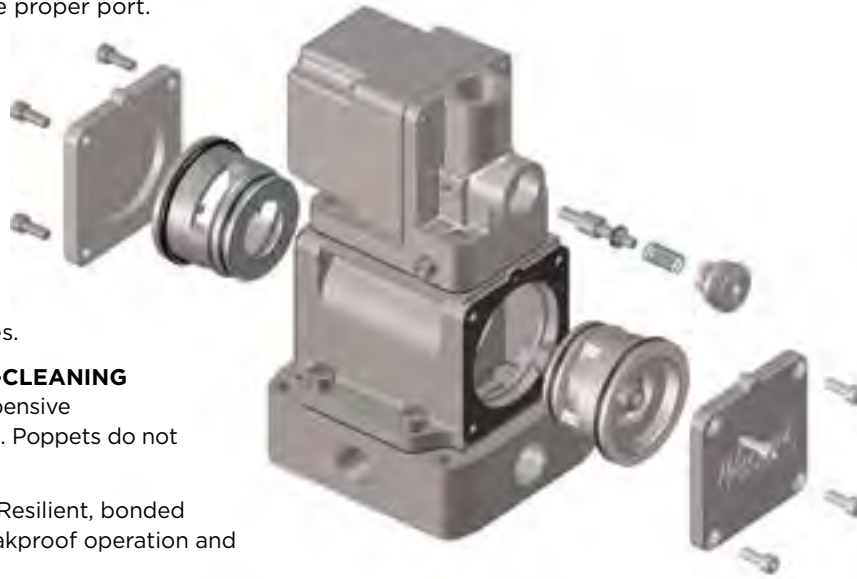
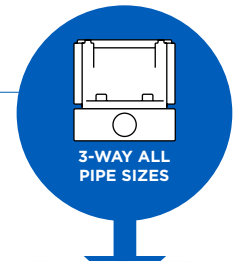

SERIES 300



SERIES 310PP



SERIES 310



SERIES 320

FEATURES AND BENEFITS ORDERING INFORMATION

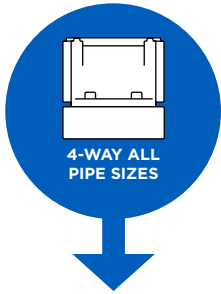

SERIES 400



SERIES 410PP



SERIES 410



SERIES 420

SERIES 310PP & 410PP

COMPACT, RELIABLE NOPAK-MATIC SINGLE SOLENOID VALVES

FEATURES AND BENEFITS

ALL PURPOSE - Developed especially as a compact, rugged, economically priced valve to solve the most demanding solenoid pilot operated air valve applications.

FOR ALL ATMOSPHERIC CONDITIONS AND APPLICATIONS - Simple pilot head operator is tolerant to dry, unlubricated air and dusty atmospheric conditions. Ideal for heavy-duty batching plant, construction, excavation and foundry applications.

FAST ACTION - Produces instantaneous valve response, even after long periods of solenoid energization or de-energization.

MANUAL OVERRIDE - Solenoid pilot available with manual override.

Single Unit - One pilot head fits all pipe size standard NOPAK-Matic master valves.

LOW WATTAGE - Efficient solenoid pilot rated at 10 operating watts in closed position.

EXPLOSION PROOF - As well as specially impregnated solenoid coils are available for hazardous, wet or high temperature environments.

FAST MAINTENANCE - Complete valve assembly can be replaced in less than 2 minutes, without disturbing piping.

REPLACEABLE, SELF-CLEANING SEATS - Fast and inexpensive to replace. Only two seat sizes required to fit all valves and are completely interchangeable within the valve or with other valves.

This valve is available with operating pressures to 125 PSI air in the 310PP and 410PP single-solenoid series only. In the case of the 4-way, when the solenoid is energized, pressure is admitted to one cylinder port, the opposite cylinder port being open to exhaust. When the solenoid is de-energized, the cycle is reversed.

Seats Replaceable Without Disturbing Plumbing.



HOW TO ORDER

WHEN ORDERING VALVES WITHOUT A SOLENOID, BE SURE TO SPECIFY: (1) Model Number and (2) Pipe Size. Unless otherwise specified, all valves shipped are for standard air service. If the "make-up bleed" feature is required, it must be ordered as such.

WHEN ORDERING VALVES WITH SOLENOID, BE SURE TO SPECIFY: (1) Model Number, (2) Pipe Size and (3) Voltage and Cycle. Unless otherwise specified, all valves are shipped for standard air service, with 115V/60 solenoids.

WHEN ORDERING VALVES FOR LOW PRESSURE (BELOW 15 PSI) OR VACUUM OPERATION, BE SURE TO SPECIFY: Remote pilot supply and add suffix "M2" to the model number.

WHEN ORDERING PARTS, BE SURE TO SPECIFY: (1) Model Number, (2) Pipe Size, (3) Item Number, (4) Part Name, (5) Part Number and (6) Voltage and Cycle.

USE 3-WAY NOPAK-MATIC VALVES:

- To control single-acting (spring-return) cylinders.
- To control double-acting cylinders:
 - Piping one 3-way valve at each end of the cylinder provides both quick exhaust and immediate pressure supply for extremely fast cylinder operation.
 - On long-stroke cylinders, using two 3-way valves eliminates filling and exhausting long lengths of pipe, thus reducing air consumption and increasing cylinder speed.
- To provide two pressure operation of a double-acting cylinder. Regulated pressure is directed to one end of cylinder through a 3-way valve, and line pressure to the other end of cylinder through the other 3-way valve.
- To provide directional control. Pressure can be piped to the outlet port and flow directed to either Port "A" or Port "B".

USE 4-WAY NOPAK-MATIC VALVES:

- To obtain reciprocating action of double-acting cylinders.
- To operate long-stroke double-acting cylinders when maximum speed is not of prime importance.
- To obtain fast action and quick reversal of short-stroke cylinders.
- To provide control of low pressure and vacuum operation. Valve is modified by the addition of spring-loaded piston-poppet valve seat assemblies and may require remote pilot supply. (Also applicable to 3-Ways.) See Engineering Section.
- To control fluids other than air. In this case, fluid is piped into the valve body and pilot air pressure is brought to the pilot head from a remote source. See Engineering Section.

SERIES 300, 310PP, 310 AND 320 3-WAY VALVES FOR NORMALLY OPEN OR NORMALLY CLOSED OPERATION	MODEL AND PIPE SIZE						
	1/4	3/8	1/2*	1/2	3/4	1	1-1/4
Series 300 Master valves for remote control	300	301	301-1/2	302	303	304	305
Series 310PP Special purpose, single solenoid	310PP	311PP	311-1/2PP	312PP	313PP	314PP	315PP
Series 310 Single solenoid valves with spring-return pilot head	310	311	311-1/2	312	313	314	315
Series 320 Double solenoid valves (momentary contact-type)	320	321	321-1/2	322	323	324	325

* = Models 301-1/2, 311-1/2 and 321-1/2 are 3/8" valves modified for 1/2" Ports.

SERIES 400, 410PP, 410 AND 420 4-WAY VALVES	MODEL AND PIPE SIZE						
	1/4	3/8	1/2*	1/2	3/4	1	1-1/4
Series 400 Master valves for remote control	400	401	401-1/2	402	403	404	405
Series 410PP Special purpose, single solenoid	410PP	411PP	411-1/2PP	412PP	413PP	414PP	415PP
Series 410 Single solenoid valves with spring-return pilot head	410	411	411-1/2	412	413	414	415
Series 420 Double solenoid valves (momentary contact-type)	420	421	421-1/2	422	423	424	425

* = Models 401-1/2, 411-1/2 and 421-1/2 are 3/8" valves modified for 1/2" Ports.

IN-LINE (ON-THE-JOB) MAINTENANCE

"In-line" maintenance is accomplished with small loss of production time. A NOPAK-Matic valve can be completely serviced in the line in less than fifteen minutes. The cover plates of the valve body, when removed, give immediate access to the piston-poppets and inserted valve seats. These parts are removable as complete assemblies. It is only a matter of minutes to completely replace all moving parts in the main valve. Damage to valve seats machined in the body can never be the cause of a NOPAK-Matic valve malfunctioning, for all valve seats are inserts and completely interchangeable.

SUBPLATE MOUNTING

NOPAK-Matic makes use of subplate mounting of all valves. A complete valve assembly can be replaced in less than two minutes simply by loosening the four mounting screws that hold the valve body assembly to the subplate. Piping need never be disturbed.

Similarly, pilot heads are quickly replaceable as a unit simply by removing the four screws attaching it to the valve body.

Precision machining of all parts and maximum interchange of parts between valves of different types and sizes allow complete service of more than one hundred valve combinations with less than twenty-five individual parts. No waiting for special parts is required to get back in operation when you use NOPAK-Matic. A very small stock of parts is required for complete service of all sizes or types of NOPAK-Matic valves.

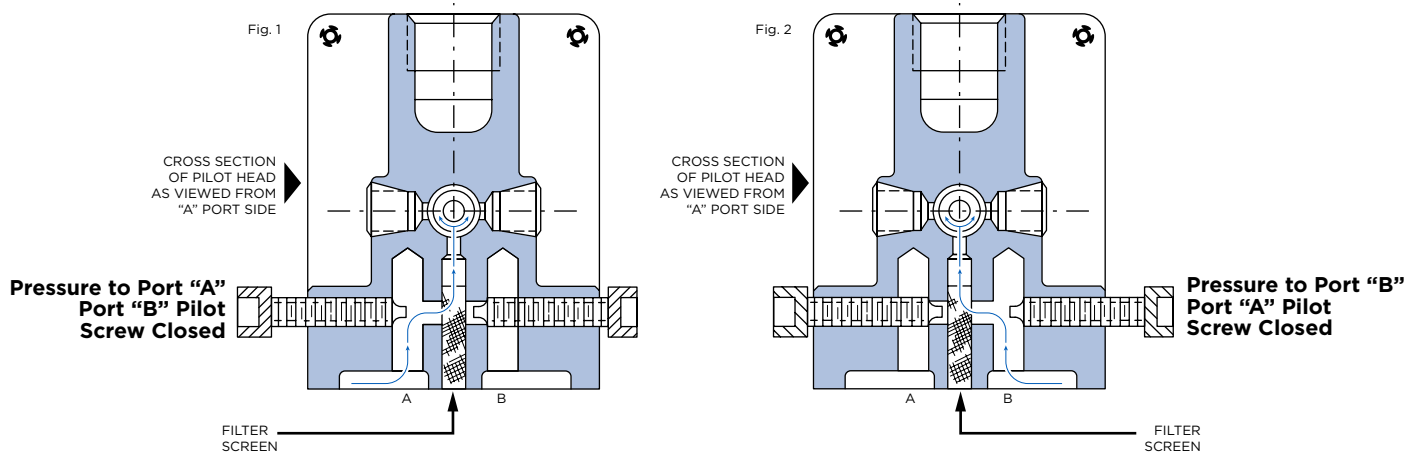

THE FLOW-DIRECTOR

The Flow-Director®, exclusive with NOPAK-Matic™, gives you the choice of a Normally Closed or Normally Open 3-way valve, without time consuming and complicated reassembly of basic parts, and precludes the expense of buying special valves for each cycle. Also, in 4-way valves, crisscross piping can be eliminated.

The Flow-Director, using two manually set pilot screws, permits line pressure to be directed from the optional supply port to the pilot head.

4-WAY SERIES 410 OR 420 SOLENOID VALVES

Unless otherwise specified, all 4-way valves are assembled for pressure supply to Port "A" and pilot screws set as in Fig. 1. If line pressure supplied to Port "B" should result in more convenient piping, reverse position of pilot screws (see Fig. 2) as follows: BACK OUT THE PILOT SCREW ABOVE PORT "B" 6 COMPLETE TURNS, counter-clockwise. Then turn in clockwise, the opposite pilot screw, (above Port "A"),

until it solidly bottoms. Then FORCE IN 1/2 TURN MORE, to ensure tight seating.

3-WAY SERIES 310 OR 320 SOLENOID VALVES

Unless otherwise specified, all 3-way valves are assembled for NORMALLY CLOSED operation, with pilot screws set as in Fig. 1: supply to Port "A"; CYL. Port(s) closed to pressure and connected to Port "B" exhaust. For NORMALLY OPEN operation, reverse setting of pilot screws as shown in Fig. 2 and connect pressure supply to Port "B".

PILOT HEAD FILTER SCREEN

All NOPAK-Matic pilot heads are equipped with a filter screen (see cross section above) to protect the pilot head seals. If screen collects an excessive amount of foreign matter, valve action may be slower than normal. If this occurs, remove and clean screen.

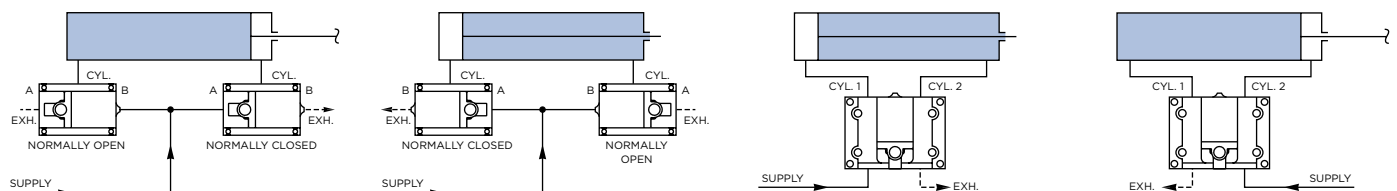

3-WAY NORMALLY OPEN OR NORMALLY CLOSED

Piping supply to Port "A" provides Normally Closed operation; supply to Port "B" provides Normally Open operation. Rotating the pilot head 180° (PP Models) or closing one Flow-Director needle or the other is all that's necessary to change operation. All 3-way valves have two cylinder outlet ports for further piping convenience.

The exclusive NOPAK-Matic Flow-Director pilot head selects pilot pressure from whichever port is used as inlet. It eliminates special valves for each application or reassembling parts. Addition of a pipe plug to any NOPAK-Matic 3-way valve converts it for 2-way operation. They can also be used for directional control.

ELIMINATE CRISSCROSS PIPING

All NOPAK-Matic 4-way valves can be piped with pressure to Port "A" or Port "B". Flow through the valve is thus changed to meet the application requirements (rod extended or retracted). Crisscross piping to the cylinder is eliminated. Here again, the Flow-Director pilot head selects pilot pressure from the inlet port. There are no extensive changes to make in the valve...just reset the needles.

MASTER VALVES

OPERATION

NORMALLY CLOSED OPERATION — Supply connected to Port “A”, “CYL” Port closed to pressure, Port “B” exhaust.

NORMALLY OPEN OPERATION — Supply connected to Port “B”, “CYL” Port open to pressure, Port “A” exhaust.

***2-WAY OPERATION** — “For 2-Way Operation” must be so specified on the order as valve must be modified by insertion of poppet return spring in the master valve.

PLUG EXHAUST PORT — “B” for Normally Closed operation, “A” for Normally Open operation. Note that two cylinder ports are provided for simplification of piping. A sealing plug is provided for the unused port.

PILOT PRESSURE — Should equal or exceed pressure in valve body.

ACTUATION — Master valves can be actuated by any 3-way valve.

OPTIONAL FEATURES

- Series 300 valves can be modified for lower pressures, vacuum operation or service other than air. See Engineering Section.

INSTALLATION DATA

- Valves must have ADEQUATE SUPPLY (VOLUME) and UNRESTRICTED EXHAUST. Supply or exhaust lines should not be reduced more than one pipe size. Speed control valves or other restrictions can be placed in the cylinder supply lines.
- These valves can be operated Normally Open or Normally Closed to pressure simply by changing the piping. See OPERATION above.
- Valves will operate mounted in any position.



- Master Valves
- 2-Way* and 3-Way
- Normally Open or Normally Closed
- 1/4", 3/8", 1/2", 3/4", 1", 1-1/4" Pipe Sizes
- Pressures 15 to 150 lbs Air

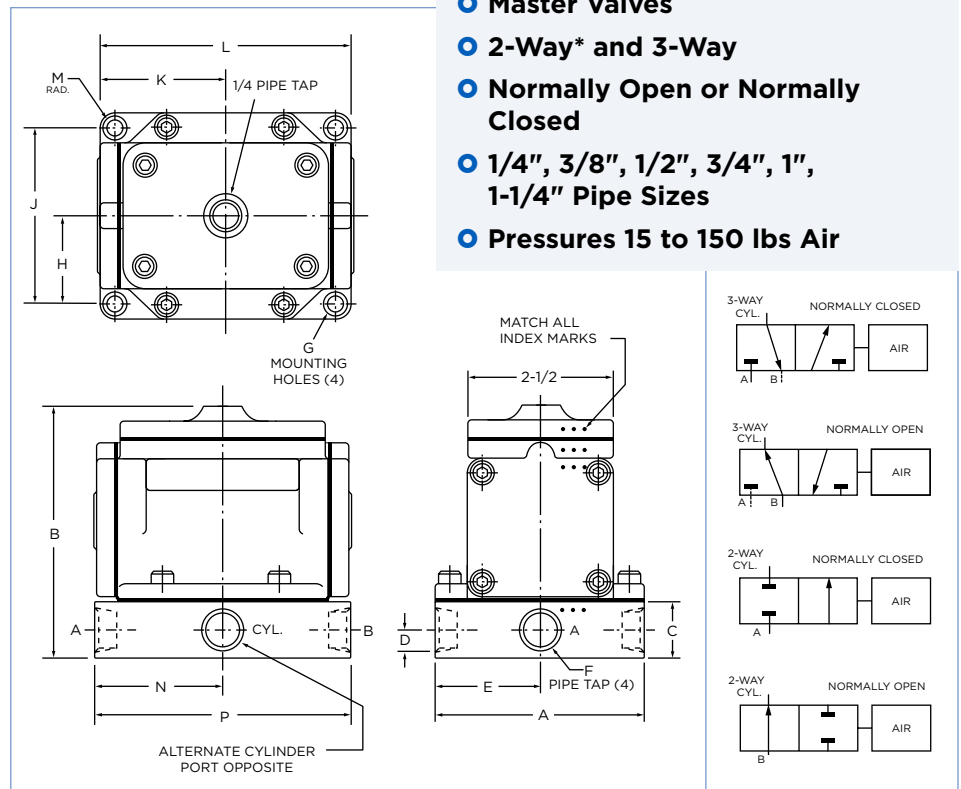

Table 1 Dimension and Installation Data

SIZE	MODEL NUMBER	DIMENSIONS IN INCHES													
		A	B	C	D	E	F	G	H	J	K	L	M	N	P
1/4	300	3-9/16	4-1/2	1-1/8	9/16	1-25/32	1/4	17/64	1-17/32	3-1/16	1-29/32	3-13/16	1/4	2-5/32	4-5/16
3/8	301	3-9/16	4-1/2	1-1/8	9/16	1-25/32	3/8	17/64	1-17/32	3-1/16	1-29/32	3-13/16	1/4	2-5/32	4-5/16
1/2•	301-1/2	3-9/16	4-1/2	1-1/8	9/16	1-25/32	1/2	17/64	1-17/32	3-1/16	1-29/32	3-13/16	1/4	2-5/32	4-5/16
1/2	302	4	5-1/16	1-1/2	3/4	2	1/2	21/64	1-11/16	3-3/8	1-3/4	3-1/2	5/16	2-5/32	4-5/16
3/4	303	4	5-1/16	1-1/2	3/4	2	3/4	21/64	1-11/16	3-3/8	1-3/4	3-1/2	5/16	2-5/32	4-5/16
1	304	4-1/4	6-1/8	2-9/16	1-3/16	2-1/8	1	11/32	1-11/16	3-3/8	2-15/16	5-7/8	3/8	3-5/16	6-5/8
1-1/4	305	4-1/4	6-1/8	2-9/16	1-3/16	2-1/8	1-1/4	11/32	1-11/16	3-3/8	2-15/16	5-7/8	3/8	3-5/16	6-5/8

• = Model 301-1/2 is the standard 301 valve with 1/2" pipe taps.

SPECIAL PURPOSE SINGLE SOLENOID VALVES

FEATURES

Simple pilot head operator, tolerant to dry, unlubricated air and dusty environment. Ideal for heavy-duty batching plant, construction, excavating and foundry applications. Instantaneous valve response even after long periods of energization or de-energization. Solenoid pilot with manual override. Available for 115, 230, 460 volt A.C.; also D.C.

***2-WAY OPERATION** — “For 2-Way Operation” must be so specified on the order as valve must be modified by insertion of poppet return spring in the master valve.

INSTALLATION DATA

- 310PP valves are assembled as standard for Normally Closed operation: supply to Port “A”, “CYL” Port blocked, Port “B” exhaust.
- Normally Open cycle can be obtained on the 310PP valves only by rotating the pilot head, but not the gasket, 180°. Inlet to Port “B”, “CYL” Port open, Port “A” to exhaust in energized position.

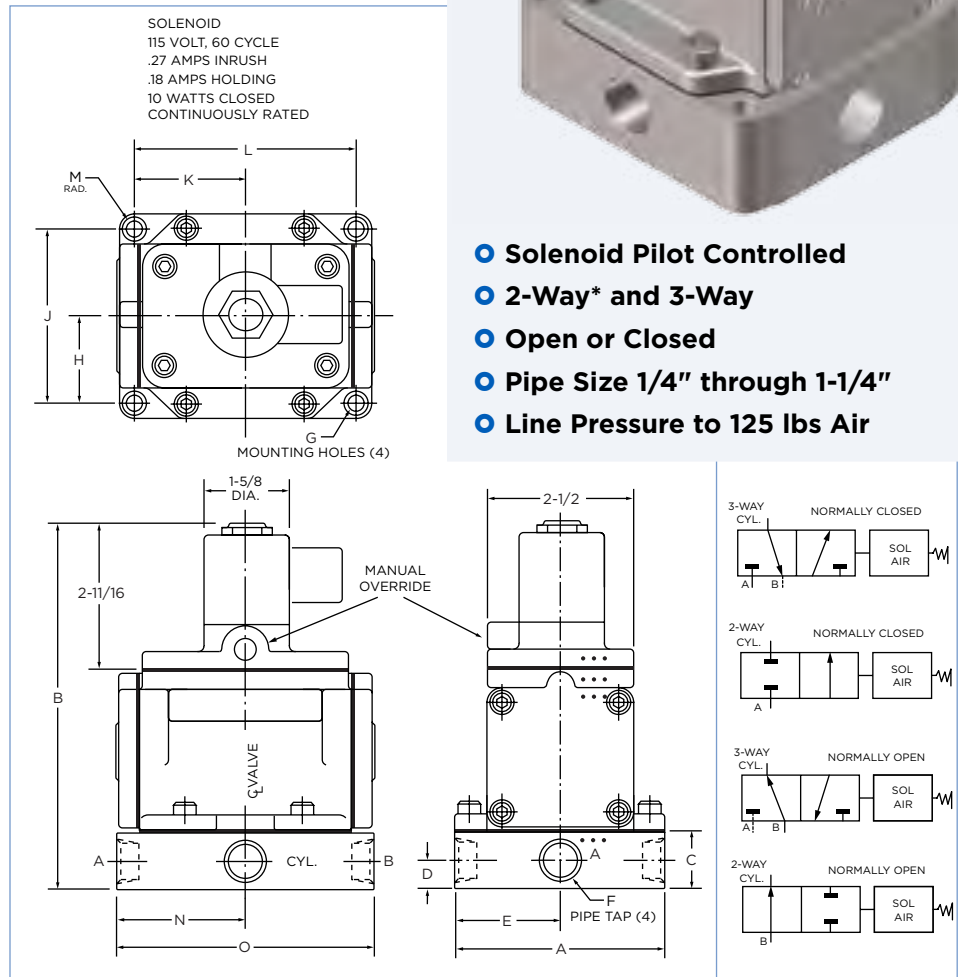

Table 1 Dimension and Installation Data

SIZE	MODEL NUMBER	DIMENSIONS IN INCHES													
		A	B	C	D	E	F	G	H	J	K	L	M	N	O
1/4	310PP	3-9/16	6-5/8	1-1/8	9/16	1-25/32	1/4	17/64	1-17/32	3-1/16	1-29/32	3-13/16	1/4	2-5/32	4-5/16
3/8	311PP	3-9/16	6-5/8	1-1/8	9/16	1-25/32	3/8	17/64	1-17/32	3-1/16	1-29/32	3-13/16	1/4	2-5/32	4-5/16
1/2*	311-1/2PP	3-9/16	6-5/8	1-1/8	9/16	1-25/32	1/2	17/64	1-17/32	3-1/16	1-29/32	3-13/16	1/4	2-5/32	4-5/16
1/2	312PP	4	7-3/16	1-1/2	3/4	2	1/2	21/64	1-11/16	3-3/8	1-3/4	3-1/2	5/16	2-5/32	4-5/16
3/4	313PP	4	7-3/16	1-1/2	3/4	2	3/4	21/64	1-11/16	3-3/8	1-3/4	3-1/2	5/16	2-5/32	4-5/16
1	314PP	4-1/4	8-1/4	2-9/16	1-3/16	2-1/8	1	11/32	1-11/16	3-3/8	2-15/16	5-7/8	3/8	3-5/16	6-5/8
1-14	315PP	4-1/4	8-1/4	2-9/16	1-3/16	2-1/8	1-1/4	11/32	1-11/16	3-3/8	2-15/16	5-7/8	3/8	3-5/16	6-5/8

* = Model 311-1/2PP is the standard 311PP valve with 1/2" pipe taps.

SINGLE SOLENOID VALVES

OPERATION

NORMALLY CLOSED OPERATION — Supply connected to Port “A”, “CYL” Port closed to pressure, Port “B” exhaust.

NORMALLY OPEN OPERATION — Supply connected to Port “B”, “CYL” Port open to pressure, Port “A” exhaust.

***2-WAY OPERATION** — “For 2-Way Operation” must be so specified on the order as valve must be modified by insertion of poppet return spring in the master valve.

PLUG EXHAUST PORT — “B” for Normally Closed operation, “A” for Normally Open operation. Note that two cylinder ports are provided for simplification of piping. A sealing plug is provided for the unused port. Also, on all valves with pilot heads, a remote supply must be provided to operate properly.

OPTIONAL FEATURES

- Indicator light: a neon pilot light can be provided to indicate the solenoid energizing.
- Solenoids for 115/50, 115/60, 230/50, 230/60, 460/50, 460/60, and 550/60 volt A.C. and 12, 16, 24, 32, 50, 90, 125, and 250 volt D.C. are in stock. Special coils, also heavy-duty and oil-immersed solenoids available on inquiry.
- Series 310 valves can be modified for lower pressures, vacuum operation or service other than air. See Engineering Section.

INSTALLATION DATA

- Valves must have ADEQUATE SUPPLY (VOLUME) and UNRESTRICTED EXHAUST. Supply or exhaust lines should not be reduced more than one pipe size. Speed control valves or other restrictions can be placed in the cylinder supply lines.
- Unless otherwise specified, Flow-Director in pilot head is set for Normally Closed operation. See OPERATION above. For Normally Open operation, setting must be reversed. - Flow-Director.
- If valve must be mounted with solenoid in a vertical position, then valve should be mounted so plunger and pilot stem climb when solenoid is energized. They are returned by spring and gravity.
- These valves should be operated with a remote pilot supply when used for service other than air, or for vacuum operation. See Engineering Section.



- Solenoid Pilot Controlled
- 2-Way* and 3-Way
- Normally Open or Normally Closed
- 1/4", 3/8", 1/2", 3/4", 1", 1-1/4" Pipe Sizes
- Pressures 15 to 125 lbs Air

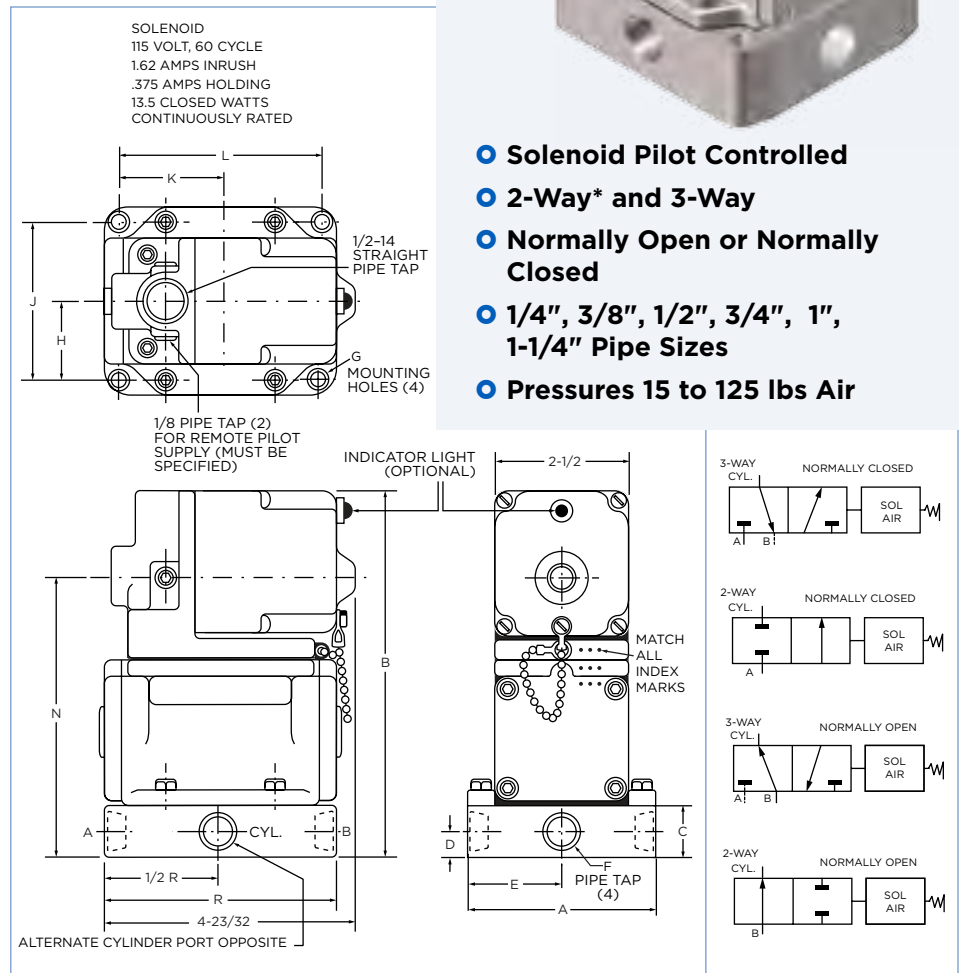

Table 1 Dimension and Installation Data

D.C. solenoids are longer than A.C. shown here. See Engineering Section for D.C. dimensions.

SIZE	MODEL NUMBER	DIMENSIONS IN INCHES												
		A	B	C	D	E	F	G	H	J	K	L	N	R
1/4	310	3-9/16	7-1/4	1-1/8	9/16	1-25/32	1/4	17/64	1-17/32	3-1/16	1-29/32	3-13/16	5-1/2	4-5/16
3/8	311	3-9/16	7-1/4	1-1/8	9/16	1-25/32	3/8	17/64	1-17/32	3-1/16	1-29/32	3-13/16	5-1/2	4-5/16
1/2*	311-1/2	3-9/16	7-1/4	1-1/8	9/16	1-25/32	1/2	17/64	1-17/32	3-1/16	1-29/32	3-13/16	5-1/2	4-5/16
1/2	312	4	7-25/32	1-1/2	3/4	2	1/2	21/64	1-11/16	3-3/8	1-3/4	3-1/2	6-1/16	4-5/16
3/4	313	4	7-25/32	1-1/2	3/4	2	3/4	21/64	1-11/16	3-3/8	1-3/4	3-1/2	6-1/16	4-5/16
1	314	4-1/4	8-3/4	2-9/16	1-3/16	2-1/8	1	21/64	1-11/16	3-3/8	2-15/16	5-7/8	7-1/4	6-5/8
1-1/4	315	4-1/4	8-3/4	2-9/16	1-3/16	2-1/8	1-1/4	21/64	1-11/16	3-3/8	2-15/16	5-7/8	7-1/4	6-5/8

* = Model 311-1/2 is the standard 311 valve with 1/2" pipe taps.

DOUBLE SOLENOID VALVES

OPERATION

NORMALLY CLOSED OPERATION — Supply connected to Port “A”, “CYL” Port closed to pressure, Port “B” exhaust.

NORMALLY OPEN OPERATION — Supply connected to Port “B”, “CYL” Port open to pressure, Port “A” exhaust.

***2-WAY OPERATION** — “For 2-Way Operation” must be so specified on the order as valve must be modified by insertion of poppet return spring in the master valve.

PLUG EXHAUST PORT — “B” for Normally Closed operation, “A” for Normally Open operation. Note that two cylinder ports are provided for simplification of piping. A sealing plug is provided for the unused port. Also, on all valves with pilot heads, a remote supply must be provided to operate properly.

OPTIONAL FEATURES

- Indicator light: a neon pilot light can be provided to indicate the solenoid energizing.
- Solenoids for 115/50, 115/60, 230/50, 230/60, 460/50, 460/60, and 550/60 volt A.C. and 12, 16, 24, 32, 50, 90, 125, and 250 volt D.C. are in stock. Heavy-duty 115 volt 60 cycle and oil immersed 115 volt 60 cycle are also in stock. Special coils, also heavy-duty and oil immersed solenoids, available on inquiry.
- Series 320 valves can be modified for lower pressures, vacuum operation or service other than air. See Engineering Section.

INSTALLATION DATA

- Valves must have ADEQUATE SUPPLY (VOLUME) and UNRESTRICTED EXHAUST. Supply or exhaust lines should not be reduced more than one pipe size. Speed control valves or other restrictions can be placed in the cylinder supply lines.
- Unless otherwise specified, Flow-Director in pilot head is set for Normally Closed operation. See OPERATION above. For Normally Open operation, setting must be reversed. See Engineering Section - Flow-Director.
- Valves will operate mounted in any position that results in the solenoids being placed in a horizontal position.
- These valves should be operated with a remote pilot supply when used for service other than air, or for vacuum operation. See Engineering Section.

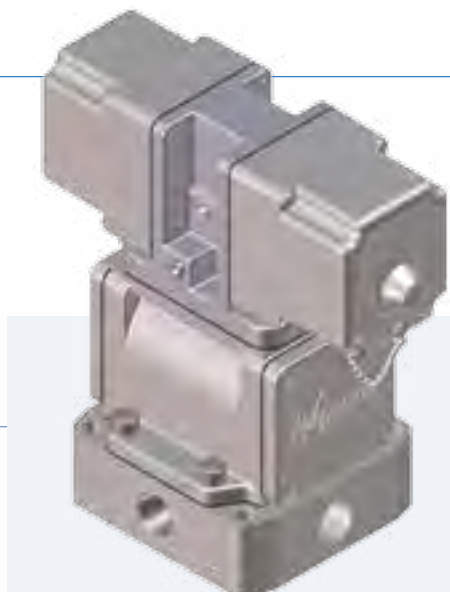
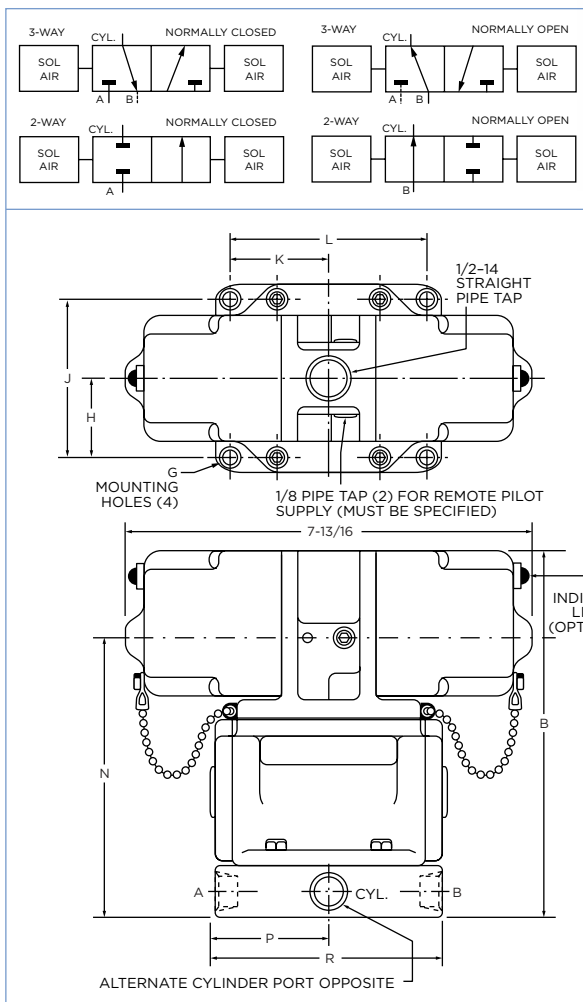

- Solenoid Pilot Controlled
- Momentary Contact Type
- 2-Way* and 3-Way
- Normally Open or Normally Closed
- 1/4", 3/8", 1/2", 3/4", 1", 1-1/4" Pipe Sizes
- Pressures 15 to 150 lbs Air

Table 1

Dimension and Installation Data

D.C. solenoids are longer than A.C. shown here. See Engineering Section for D.C. dimensions.

SIZE	MODEL NUMBER	DIMENSIONS IN INCHES													
		A	B	C	D	E	F	G	H	J	K	L	N	P	R
1/4	320	3-9/16	7-1/4	1-1/8	9/16	1-25/32	1/4	17/64	1-17/32	3-1/16	1-29/32	3-13/16	5-1/2	2-5/32	4-5/16
3/8	321	3-9/16	7-1/4	1-1/8	9/16	1-25/32	3/8	17/64	1-17/32	3-1/16	1-29/32	3-13/16	5-1/2	2-5/32	4-5/16
1/2	321-1/2	3-9/16	7-1/4	1-1/8	9/16	1-25/32	1/2	17/64	1-17/32	3-1/16	1-29/32	3-13/16	5-1/2	2-5/32	4-5/16
1/2	322	4	7-25/32	1-1/2	3/4	2	1/2	21/64	1-11/16	3-3/8	1-3/4	3-1/2	6-1/16	2-5/32	4-5/16
3/4	323	4	7-25/32	1-1/2	3/4	2	3/4	21/64	1-11/16	3-3/8	1-3/4	3-1/2	6-1/16	2-5/32	4-5/16
1	324	4-1/4	8-3/4	2-9/16	1-3/16	2-1/8	1	21/64	1-11/16	3-3/8	2-15/16	5-7/8	7-1/4	3-5/16	6-5/8
1-1/4	325	4-1/4	8-3/4	2-9/16	1-3/16	2-1/8	1-1/4	21/64	1-11/16	3-3/8	2-15/16	5-7/8	7-1/4	3-5/16	6-5/8

* = Model 321-1/2 is the standard 321 valve with 1/2" pipe taps.

MASTER VALVES

OPERATION

Port "A" INLET — Supply connected to Port "A", "CYL 2" Port open to pressure, "CYL 1" Port open to exhaust through Port "B".

Port "B" INLET — Supply connected to Port "B", "CYL 1" Port open to pressure, "CYL 2" Port open to exhaust through Port "A".

PILOT PRESSURE — Should equal or exceed pressure in valve body.

ACTUATION — Master valves can be actuated by any 3-way valve.

OPTIONAL FEATURES

- Series 400 valves can be modified for lower pressures, vacuum operation or service other than air. See Engineering Section.

INSTALLATION DATA

- Valves must have ADEQUATE SUPPLY (VOLUME) and UNRESTRICTED EXHAUST. Supply or exhaust lines should not be reduced more than one pipe size. Speed control valves or other restrictions can be placed in the cylinder supply lines.
- These valves can be piped with either Port "A" or Port "B" as inlet. See OPERATION above.
- Valves will operate mounted in any position.

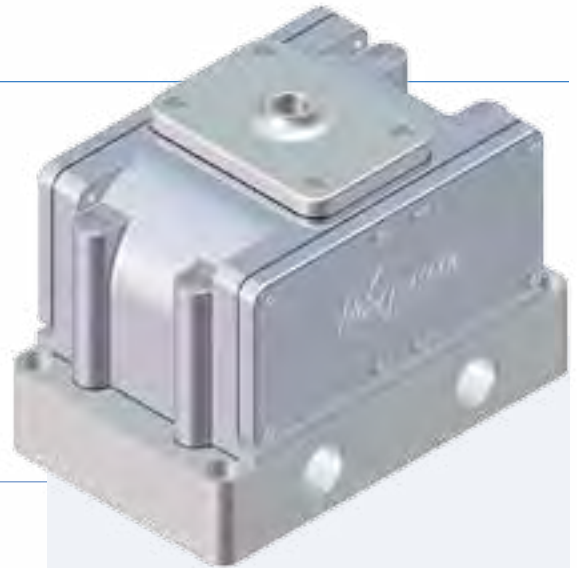

- Master Valves
- 4-Way
- 1/4", 3/8", 1/2", 3/4", 1", 1-1/4" Pipe Sizes
- Pressures 15 to 150 lbs Air

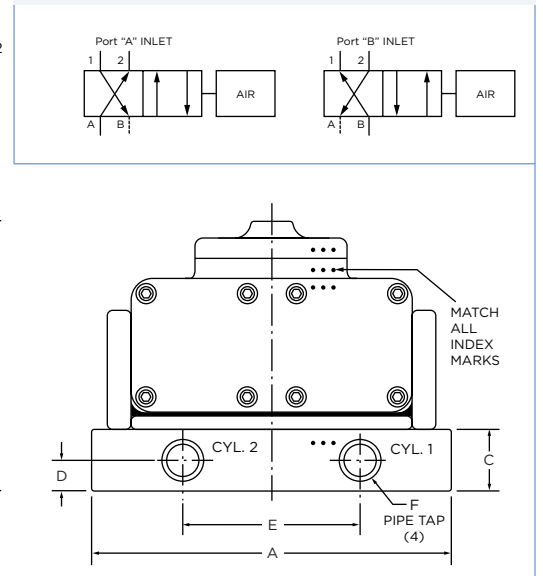
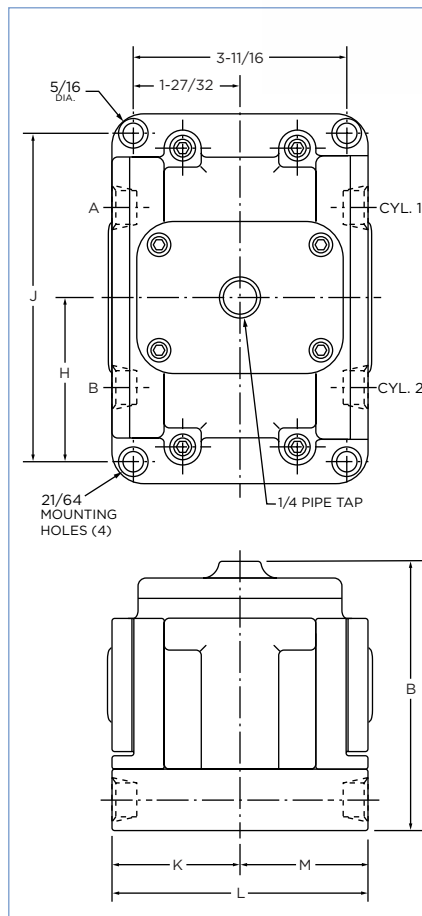

Table 1 Dimension and Installation Data

SIZE	MODEL NUMBER	DIMENSIONS IN INCHES										
		A	B	C	D	E	F	H	J	K	L	M
1/4	400	6-1/8	4-11/16	1-1/8	1/2	2-9/16	1/4	2-3/4	5-1/2	2-5/32	4-5/16	2-5/32
3/8	401	6-1/8	4-11/16	1-1/8	1/2	2-9/16	3/8	2-3/4	5-1/2	2-5/32	4-5/16	2-5/32
1/2	401-1/2	6-1/8	4-11/16	1-1/8	1/2	2-9/16	1/2	2-3/4	5-1/2	2-5/32	4-5/16	2-5/32
1/2	402	7	5-13/16	1-7/16	3/4	3	1/2	3-3/16	6-3/8	2-5/32	4-5/16	2-5/32
3/4	403	7	5-13/16	1-7/16	3/4	3	3/4	3-3/16	6-3/8	2-5/32	4-5/16	2-5/32
1	404	7-1/4	6-7/8	2	1	2-15/16	1	3-3/16	6-3/8	2-27/32	5	2-5/32
1-1/4	405	7-1/4	6-7/8	2	1	2-15/16	1-1/4	3-3/16	6-3/8	2-27/32	5	2-5/32

* = Model 401-1/2 is the standard 401 valve with 1/2" pipe taps.

SPECIAL PURPOSE SINGLE SOLENOID VALVES

FEATURES

Simple pilot head operator, tolerant to dry, unlubricated air and dusty environment. Ideal for heavy-duty batching plant, construction, excavating and foundry applications. Instantaneous valve response even after long periods of energization or de-energization. Pilot with manual override. Available for 115, 230, 460 volt A.C.; also D.C.

INSTALLATION DATA

410PP valves are assembled as standard with Port "A" as pressure port. Energizing the solenoid pressurizes "CYL" Port 1 with "CYL" Port 2 open to exhaust. When the solenoid is de-energized, the cycle is reversed.



- Solenoid Pilot Controlled
- Maintained Contact Type
- 4-Way
- Pipe Sizes 1/4" through 1-1/4"
- Line Pressure to 125 PSI Air

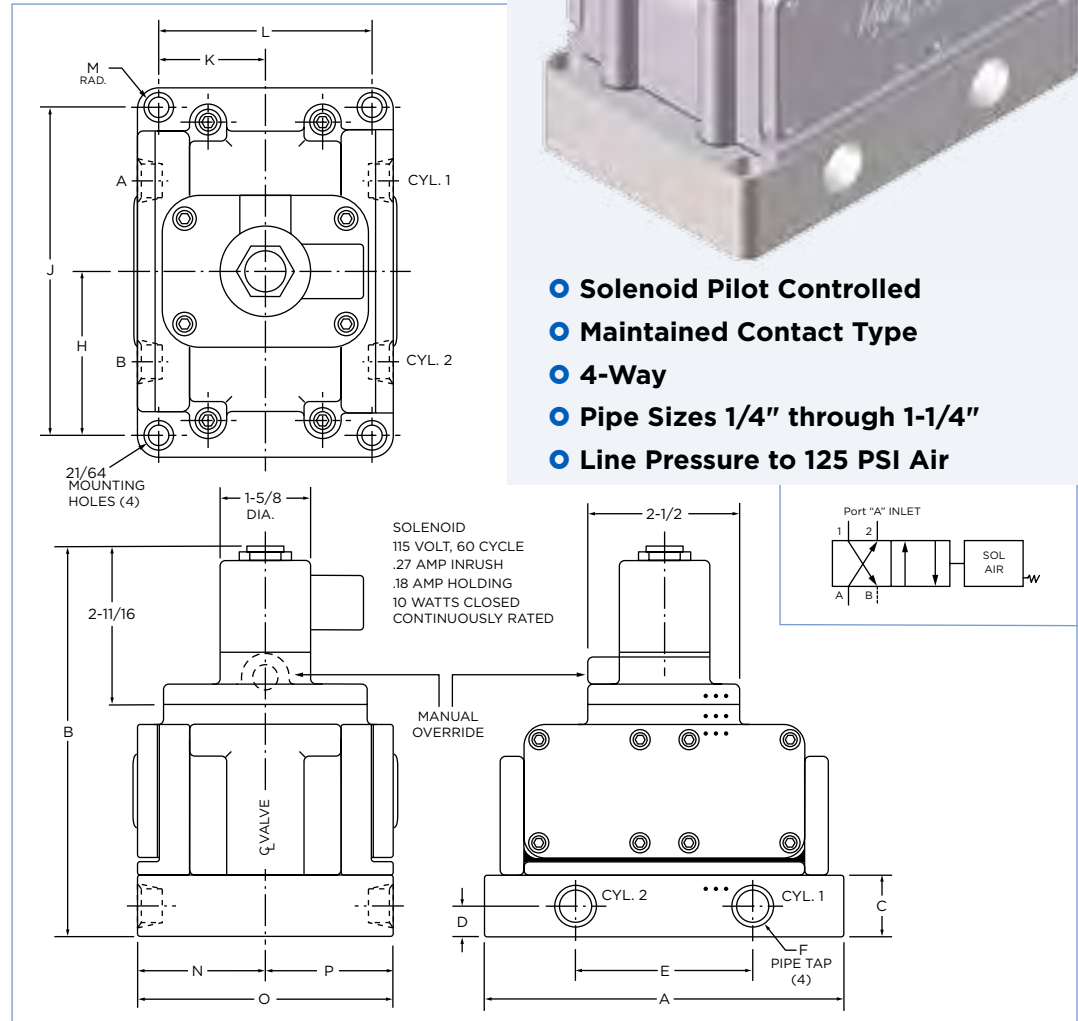

Table 1 Dimension and Installation Data

SIZE	MODEL NUMBER	DIMENSIONS IN INCHES													
		A	B	C	D	E	F	H	J	K	L	M	N	O	P
1/4	410PP	6-1/8	6-13/16	1-1/8	1/2	2-9/16	1/4	2-3/4	5-1/2	1-27/32	3-11/16	1/4	2-5/32	4-5/16	2-5/32
3/8	411PP	6-1/8	6-13/16	1-1/8	1/2	2-9/16	3/8	2-3/4	5-1/2	1-27/32	3-11/16	1/4	2-5/32	4-5/16	2-5/32
1/2•	411-1/2PP	6-1/8	6-13/16	1-1/8	1/2	2-9/16	1/2	2-3/4	5-1/2	1-27/32	3-11/16	1/4	2-5/32	4-5/16	2-5/32
1/2	412PP	7	7-15/16	1-7/16	3/4	3	1/2	3-3/16	6-3/8	1-3/4	3-1/2	5/16	2-5/32	4-5/16	2-5/32
3/4	413PP	7	7-15/16	1-7/16	3/4	3	3/4	3-3/16	6-3/8	1-3/4	3-1/2	5/16	2-5/32	4-5/16	2-5/32
1	414PP	7-1/4	9	2	1	2-15/16	1	3-3/16	6-3/8	2-15/16	5-7/8	3/8	2-27/32	5	2-5/32
1-1/4	415PP	7-1/4	9	2	1	2-15/16	1-1/4	3-3/16	6-3/8	2-15/16	5-7/8	3/8	2-27/32	5	2-5/32

• = Model 411-1/22PP is the standard 411PP with 1/2" ports.

SINGLE SOLENOID VALVES

OPERATION

Port "A" INLET — Supply connected to Port "A", "CYL 2" Port open to pressure, "CYL 1" Port open to exhaust through Port "B".

Port "B" INLET — Supply connected to Port "B", "CYL 1" Port open to pressure, "CYL 2" Port open to exhaust through Port "A".

OPTIONAL FEATURES

- Indicator light: a neon pilot light can be provided to indicate the solenoid energizing.
- Solenoids for 115/50, 115/60, 230/50, 230/60, 460/50, 460/60, and 550/60 volt A.C. and 12, 16, 24, 32, 50, 90, 125, and 250 volt D.C. are in stock. Heavy-duty 115 volt 60 cycle and oil immersed 115 volt 60 cycle are also in stock. Special coils, also heavy-duty and oil immersed solenoids, available on inquiry.
- Series 410 valves can be modified for lower pressures, vacuum operation or service other than air. See Engineering Section.

INSTALLATION DATA

- Valves must have ADEQUATE SUPPLY (VOLUME) and UNRESTRICTED EXHAUST. Supply or exhaust lines should not be reduced more than one pipe size. Speed control valves or other restrictions can be placed in the cylinder supply lines.
- Unless otherwise specified, Flow-Director in pilot head is set for Port "A" inlet. See OPERATION above. For Port "B" inlet, setting must be reversed. See Engineering Section - Flow-Director.
- If valve must be mounted with solenoid in a vertical position, then valve should be mounted so plunger and pilot stem climb when solenoid is energized. They are returned by spring and gravity.
- These valves should be operated with a remote pilot supply when used for service other than air, or for vacuum operation. See Engineering Section.

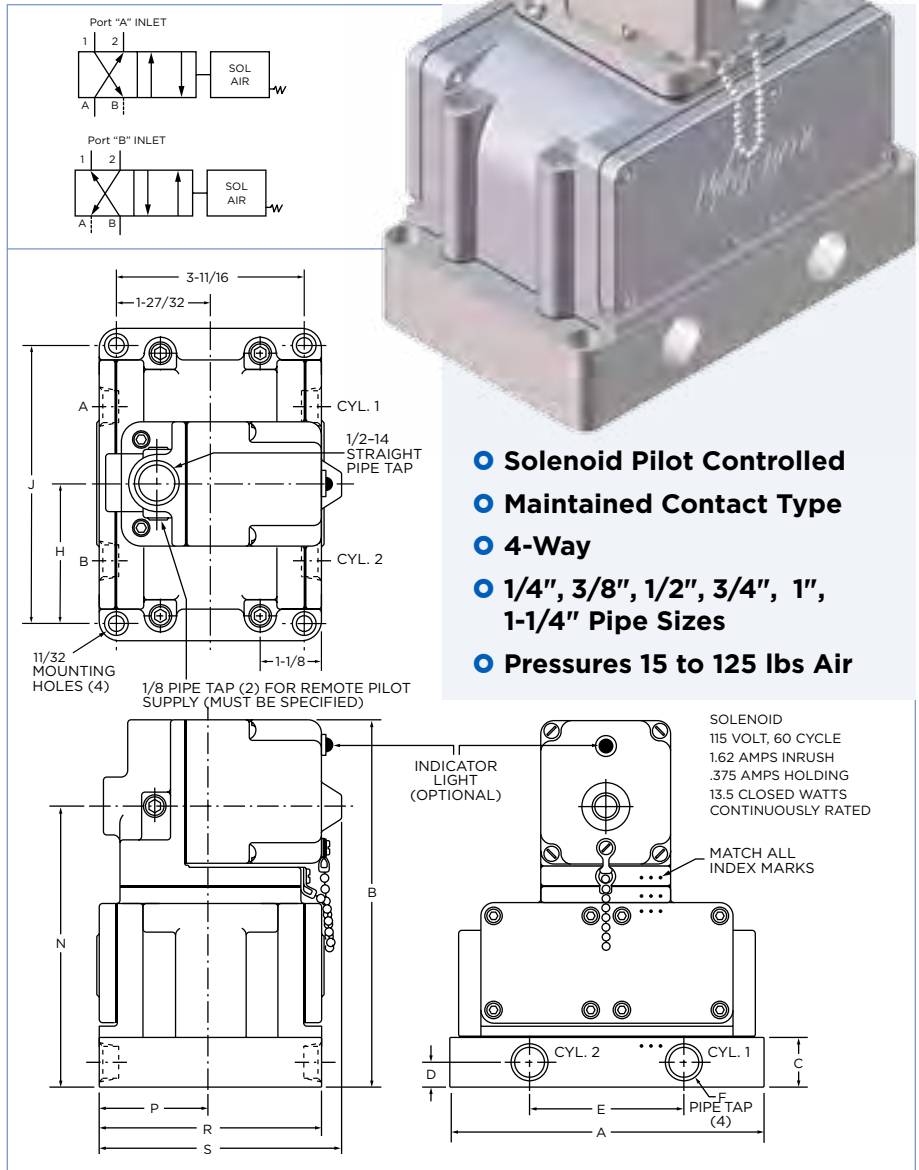
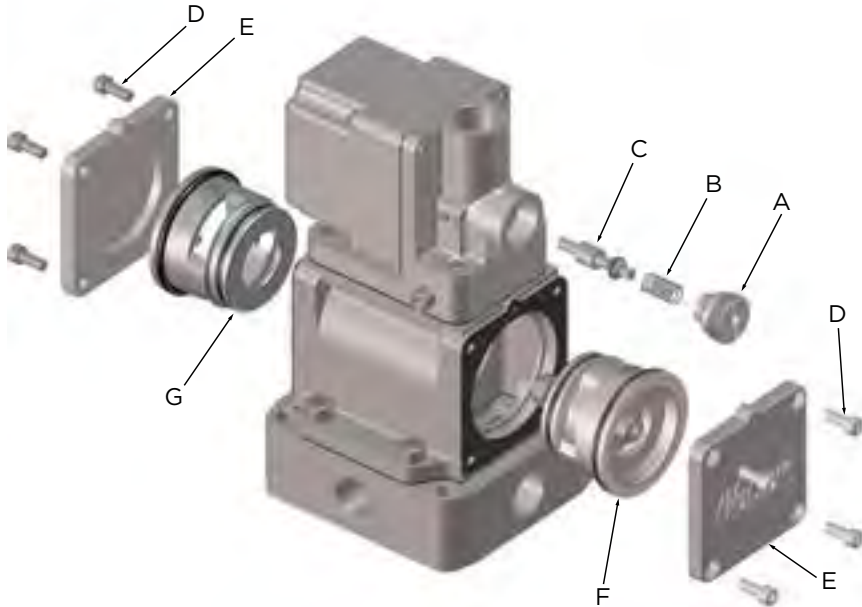

Table 1 Dimension and Installation Data
D.C. solenoids are longer than A.C. shown here. See Engineering Section for D.C. dimensions.

SIZE	MODEL NUMBER	DIMENSIONS IN INCHES											
		A	B	C	D	E	F	H	J	N	P	R	S
1/4	410	6-1/8	7-7/16	1-1/8	1/2	2-9/16	1/4	2-3/4	5-1/2	5-3/4	2-5/32	4-5/16	4-23/32
3/8	411	6-1/8	7-7/16	1-1/8	1/2	2-9/16	3/8	2-3/4	5-1/2	5-3/4	2-5/32	4-5/16	4-23/32
1/2*	411-1/2	6-1/8	7-7/16	1-1/8	1/2	2-9/16	1/2	2-3/4	5-1/2	5-3/4	2-5/32	4-5/16	4-23/32
1/2	412	7	7-15/16	1-7/16	3/4	3	1/2	3-3/16	6-3/8	6-1/4	2-5/32	4-5/16	4-23/32
3/4	413	7	7-15/16	1-7/16	3/4	3	3/4	3-3/16	6-3/8	6-1/4	2-5/32	4-5/16	4-23/32
1	414	7-1/4	8-7/16	2	1	2-15/16	1	3-3/16	6-3/8	6-3/4	2-11/16	5	5-9/32
1-1/4	415	7-1/4	8-7/16	2	1	2-15/16	1-1/4	3-3/16	6-3/8	6-3/4	2-11/16	5	5-9/32

* = Model 411-1/2 is the standard 411 valve with 1/2" pipe taps.

DISASSEMBLY



CAUTION! Always shut off electrical and pressure supply and bleed all lines before any disassembly.

REMOVAL OF PILOT STEM

- 1 Unscrew pilot stem spring retainer nut A.
- 2 Remove spring B.
- 3 Push manual operating button. Then carefully pull out exposed pilot stem C.

REMOVAL OF PISTON-POPPET ASSEMBLIES

- 1 Remove socket head cap screws D on both sides of valve.
- 2 Drop valve body cover plates E.
- 3 Push out poppet assembly cartridge F by nudging with wooden dowel inserted through hole in valve seat cartridge G. Then push out cartridge G by inserting dowel into opening exposed by removal of cartridge F. (A wooden dowel should be used to prevent damage to sealing surfaces.)

ASSEMBLY

- 1 All parts should be carefully cleaned so that foreign particles are removed. Be sure to also check pilot head filter screen.
- 2 Moving parts must be lightly oiled with recommended lubricant; see list on page 168.
- 3 Damaged gaskets should be replaced.
- 4 Assemble parts in reverse order of disassembly.
- 5 Tighten all screws systematically to obtain an even pull-down. Do not over-tighten.

REMOTE PILOT SUPPLY

All NOPAK-Matic 2-, 3- and 4-way solenoid operated valves can be adapted for low pressure (below 15 PSI) vacuum service.

To accomplish this it is necessary to remotely supply the pilot section with at least 15 PSI air in order to shift the main poppets. Two special 1/8" NPT inlets are tapped into the pilot section, as shown below right, to bring the pilot air supply into either pilot inlet port. One inlet is sufficient, but two are supplied for convenience of piping. Unused port is plugged. Both pilot selector screws must be fully closed to ensure isolation of pilot section from master section of valve.

When using other media (oil for example), even at standard operating pressures, it is still necessary to bring air pressure to the pilot section, via the remote pilot supply feature. **Pilot pressure must meet or exceed main inlet pressure.** When ordering, please specify "Remote Pilot Supply." Also indicate:

- 1 Vacuum: specify maximum vacuum in HQ or equivalent. Special return spring will be furnished in piston-poppet assembly (see above).
- 2 Low pressure (below 15 PSI): special return spring furnished in piston-poppet assembly (see above).
- 3 Other media
 - A Type, description and specifications.
 - B Pressure.
 - C Temperature.
- 4 Voltage and cycle.

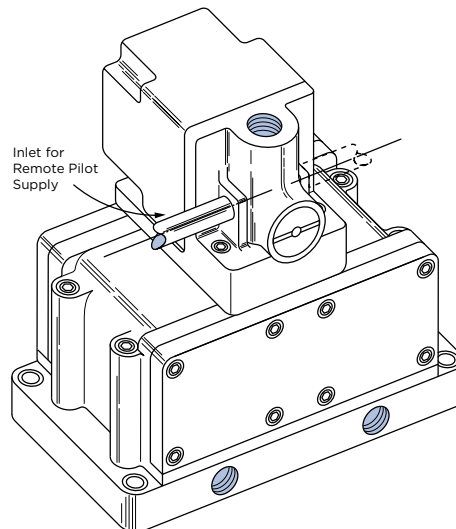

MAKE-UP BLEED

NOPAK-Matic Master 3-Way or 4-Way Valves, supplied with a “make-up bleed” feature, eliminate the need of maintaining constant pilot pressure to hold the master valve in the energized position.

Normally, a 3-way valve is required to pilot the NOPAK-Matic master valve. With “make-up bleed,” two 2-way Normally Closed pilot valves can be used as follows: the first directs pressure into pilot head, the second exhausts pilot head to atmosphere.

As shown in the sketch to the right, a small orifice is drilled in the master valve body connecting the center chamber to the master valve head. When the valve is de-energized, the center chamber as well as the master valve head is exhausted.

A momentary actuation of the first 2-way pilot valve puts an impulse of air into the master valve head and moves the piston-poppet over to the energized position. This pressurizes the center chamber and make-up bleed continues to supply pressure to master valve head to compensate for any leakage through fittings, elbows, pipes, etc., after the first 2-way pilot valve has been closed. When the second 2-way pilot valve is momentarily actuated, air from the master valve head exhausts faster than the make-up bleed orifice can replenish the supply, resulting in the piston-poppet shifting back to the de-energized position.

Customer must specify “make-up bleed” when ordering this valve.

NOPAK-MATIC VALVES FOR LOW PRESSURE OR VACUUM OPERATION

NOPAK-Matic valves can be adapted to low-pressure (below 15 PSI) or vacuum operation by the addition of a spring(s) in the piston-poppet seat assembly.

High pressure from the pilot head shifts the piston-poppet in one direction, spring pressure returns it to seat. Supply pressure from the pilot head must be 15 PSI or more.

When ordering, specify modification desired: “M2 Low Pressure” or “M2 Vacuum”.

See bottom of page 166 for remote pilot supply operation.

- ENGINEERING**
- Make-Up Bleed
 - Spring Loaded Piston-Poppet
 - Flow-Director
 - Proper Lubricants

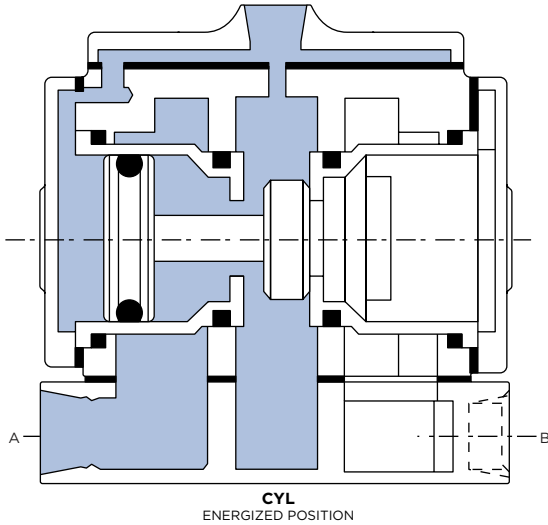
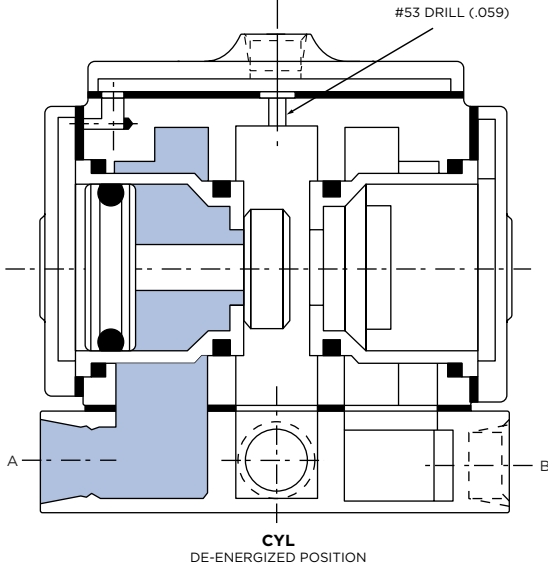
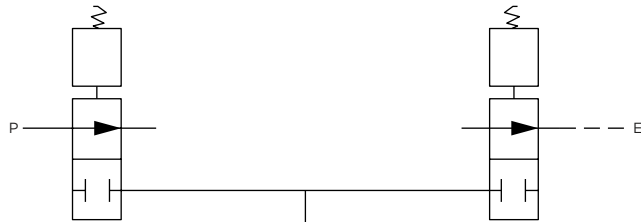

■ PRESSURE □ EXHAUST

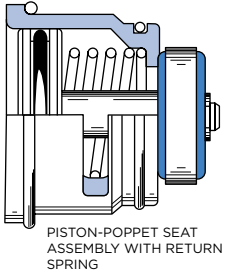

DIRECT CURRENT SOLENOIDS

Drawings on this page give dimensions of D.C. solenoids mounted on standard NOPAK-Matic pilot heads. All other valve dimensions are the same as shown on each catalog sheet. Solenoids for 12, 16, 24, 32, 50, 90, 125 and 250 D.C. are in stock. Other voltages are available on request. For complete cost data, see price sheet.

NOTE: Both single and double solenoid valves use No. 24-80 solenoids with coils No. 9-27 (watts = 36) inrush amps = holding amps then for 25 volts D.C., $A = 36/24 = 1.5$ amps

AMBIENT TEMPERATURES — NOPAK-Matic valves with solenoids will function trouble-free in temperatures to 140°F. Check with NOPAK for special solenoids for temperatures in excess of 140°F.

ENGINEERING

- Direct Current Solenoids
- Ambient Temperatures
- Pressure Drop vs. Air Flow

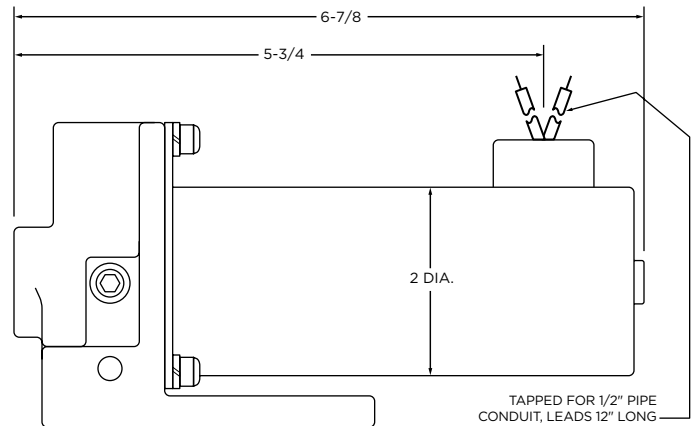

SINGLE SOLENOID PILOT HEAD FOR SERIES 310 AND 410 VALVES

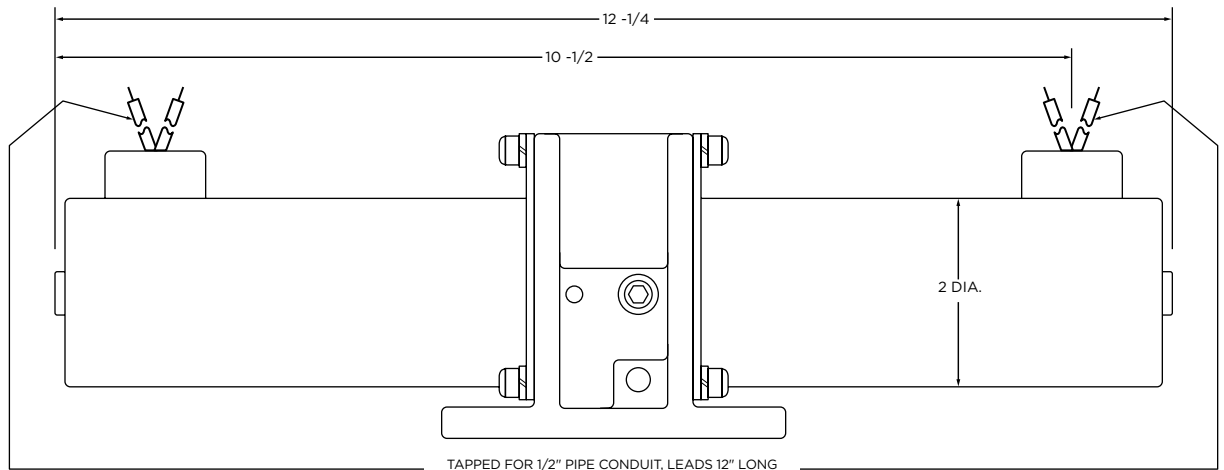

DOUBLE SOLENOID PILOT HEAD FOR SERIES 320 AND 420 VALVES

USE AIR LINE FILTER, PROPER LUBRICANTS

TO ENSURE maximum performance, NOPAK-Matic Valves should be supplied with CLEAN LUBRICATED air. We recommend use of an air line filter and lubricator, BOTH OF AMPLE FLOW CAPACITY, installed as close as possible ahead of the valve and cylinder. DO NOT USE oils having any detergent additives. Following is a representative list of oil refiners and their particular brands.

NOTE: Chemical composition may vary somewhat due to geographical areas in which these lubricants are produced.

Cities Service Oil Co	North Star #2
Esso Standard Oil	Teresso #43 or Teresstic #43
Gulf Oil Co	Harmony #44 or Security #44
N.Y. & N.J. Lubricant Co	A-#88/HNR
Shell Oil Co	Tellus #27 or Turbo #27
Sinclair Refining Co	Rubilene-Extra Light
Saony-Mobile Oil Co	D.T.E. Light
Standard Oil of Calif	Chevron GST Oil #32
Texaco	Regal A.R. & O.
Union Oil of Calif	Red Line Turbine Oil #150

C_v FACTORS FOR NOPAK-MATIC VALVES

To assist in the selection of NOPAK-Matic valves, the following flow coefficients of the various models and pipe sizes have been determined in accordance with the standard air flow equation:

$$C_v = \frac{Q \times 60}{1360} \sqrt{\frac{G \times T_u}{\Delta P \times P_u}}$$

in which

- C_v = flow coefficient
- Q = air flow in standard units, scfm (14.7 PSI, 68°F)
- G = specific gravity, air @ 68°F
- T_u = absolute temp. (deg. F + 460)
- ΔP = pressure drop, PSI
- P_u = pressure in absolute units (subscript “u” = upstream)

then

$$C_v = \frac{Q \times 60}{1360} \sqrt{\frac{.932 \times (68 + 460)}{\Delta P \times (100 + 14.7)}}$$

For values of C_v and pressure drops at 100 PSI entering air pressure.

For our NOPAK-Matic valves the following C_v factors apply:

3-WAY			
MODEL	NPTF SIZE	C _v	
		ΔP = .15	ΔP = .40
300	1/4	5.66	5.13
310	1/4	5.66	5.13
320	1/4	5.66	5.13
301	3/8	6.28	5.63
311	3/8	6.28	5.63
321	3/8	6.28	5.63
301-1/2	1/2	7.37	6.60
311-1/2	1/2	7.37	6.60
321-1/2	1/2	7.37	6.60
302	1/2	7.74	6.93
312	1/2	7.74	6.93
322	1/2	7.74	6.93
303	3/4	8.33	7.58
313	3/4	8.33	7.58
323	3/4	8.33	7.58
304	1	11.3	10.1
314	1	11.3	10.1
324	1	11.3	10.1
305	1-1/4	12.0	10.8
315	1-1/4	12.0	10.8
325	1-1/4	12.0	10.8

4-WAY			
MODEL	NPTF SIZE	C _v	
		ΔP = .15	ΔP = .40
400	1/4	2.83	2.74
410	1/4	2.83	2.74
420	1/4	2.83	2.74
401	3/8	3.42	3.32
411	3/8	3.42	3.32
421	3/8	3.42	3.32
401-1/2	1/2	4.21	4.13
411-1/2	1/2	4.21	4.13
421-1/2	1/2	4.21	4.13
402	1/2	4.48	4.41
412	1/2	4.48	4.41
422	1/2	4.48	4.41
403	3/4	4.72	4.62
413	3/4	4.72	4.62
423	3/4	4.72	4.62
404	1	6.42	6.28
414	1	6.42	6.28
424	1	6.42	6.28
405	1-1/4	6.72	6.50
415	1-1/4	6.72	6.50
425	1-1/4	6.72	6.50

To determine the C_v factor for supply pressure at other than 100 PSIG, calculate ΔP and Q in accordance with the information given in the Pressure Drop vs. Air Flow graph on the next page and then substitute these new values in the above equation.

